



ReadySystem™ ATX Users Guide

P/N 5001788A Revision A

Notice Page

NOTICE

No part of this document may be reproduced, transmitted, transcribed, stored in a retrieval system, or translated into any language or computer language, in any form or by any means, electronic, mechanical, magnetic, optical, chemical, manual, or otherwise, without the prior written permission of Ampro Computers, Incorporated.

DISCLAIMER

Ampro Computers, Incorporated makes no representations or warranties with respect to the contents of this manual or of the associated Ampro products, and specifically disclaims any implied warranties of merchantability or fitness for any particular purpose. Ampro shall under no circumstances be liable for incidental or consequential damages or related expenses resulting from the use of this product, even if it has been notified of the possibility of such damages. Ampro reserves the right to revise this publication from time to time without obligation to notify any person of such revisions. If errors are found, please contact Ampro at the address listed below on the Notice page of this document.

TRADEMARKS

Ampro and the Ampro logo are registered trademarks, and CoreModule, EnCore, Little Board, LittleBoard, MightyBoard, MiniModule, ReadyBoard, ReadyBox, and ReadySystem are trademarks of Ampro Computers, Inc. All other marks are the property of their respective companies.

REVISION HISTORY

Revision	Reason for Change	Date
A, A	Initial Release	Jan/06

Ampro Computers, Incorporated
5215 Hellyer Avenue
San Jose, CA 95138-1007
Tel. 408 360-0200
Fax 408 360-0222
www.ampro.com

© Copyright 2006, Ampro Computers, Incorporated

Audience Assumptions

This guide is for the person who designs or uses computer related equipment, including but not limited to hardware and software design and implementation of the same. Ampro Computers, Inc. assumes you are qualified in designing and implementing your hardware designs and its related software into your prototype computer equipment.

Contents

Chapter 1	Setting Up the ReadySystem ATX	1
About the ReadySystem ATX	1
Using this Guide	1
Requirements	1
What's in the Box	1
Setup Steps	2
Preparations	2
Setting Up the Workspace	2
Installing the Mounting Hardware	3
Connecting the Peripherals	4
Applying Power to the ReadySystem ATX	6
Chapter 2	Installing ReadySystem ATX Options	7
Compact Flash Card Installation	7
Tools Required	7
Installing the Compact Flash Card	7
Removing the Compact Flash Card	9
ReadySystem ATX Disassembly/Reassembly	10
Tools Required	10
Removing the ReadyBoard from Enclosure	10
Installing the ReadyBoard	13
Connecting the Cables	15
Memory Installation	17
Tools Required	17
Installation Guidelines	17
Removing the SODIMM	17
Installing the SODIMM	19
Appendix A	Technical Support	21
Appendix B	System Overview	23
EPIC Architecture	23
Product Description	24
ReadyBox ATX Features	25
I/O Panel Description	26
Power/IDE LED Definitions	27
Specifications	27
Environmental Specifications	27
Power Specifications	28
Enclosure Cooling Requirements	28
Physical Specifications	28
Mechanical Specifications	29
Mounting Locations, Access Plates, and Covers	31
List of Figures		
Figure 1-1. ReadySystem ATX Accessories	3
Figure 1-2. Installing the Mounting Hardware	3
Figure 1-3. I/O Panel Controls and Connectors	4

Contents

Figure 2-1. Removing Compact Flash Protective Cover	8
Figure 2-2. Installing the Compact Flash Card	9
Figure 2-3. Removing the ReadySystem ATX Top Cover	11
Figure 2-4. Disconnecting the Cables	11
Figure 2-5. Removing ReadyBoard from Enclosure	12
Figure 2-6. Internal Cables Shown Separated	13
Figure 2-7. ReadyBoard Positioned Under LAN Ports	14
Figure 2-8. Installing ReadyBoard into Enclosure	14
Figure 2-9. Connector Locations (Typical ReadyBoard)	15
Figure 2-10. Connector Pin-1 Locations (Typical ReadyBoard)	16
Figure 2-11. Removing SODIMM from Socket	18
Figure 2-12. Installing SODIMM into Socket	20
Figure B-1. Stacking PC/104 Modules in ReadyBox ATX (Side view)	23
Figure B-2. ReadyBox ATX Enclosure (No ReadyBoard)	24
Figure B-3. I/O Panel Controls and Connectors	26
Figure B-4. Width and Height Dimensions (Front view)	29
Figure B-5. Width and Depth Dimensions (Top view)	29
Figure B-6. Wall Mounting Dimensions (I/O Panel view)	30
Figure B-7. Surface or Benchtop Mounting Dimensions (Top view)	30
Figure B-8. Mounting and PC/104 I/O Access Plate Locations	31
Figure B-9. Enclosure Cover Locations	32

List of Tables

Table 1-1. ReadySystem ATX I/O Panel Connectors, Controls, and Indicators	5
Table A-1. Technical Support Contact Information	21
Table B-1. Installed Connectors or Controls	26
Table B-2. Connectors or Control/Indicator I/O Panel Openings	27
Table B-3. Power/IDE Activity LED Indicators	27
Table B-4. Environmental Requirements	27
Table B-5. Power Supply Specifications	28
Table B-6. Optional System Fan Required	28
Table B-7. Weight and Footprint Dimensions	28
Table B-8. Access Plate Dimensions	31

Chapter 1 Setting Up the ReadySystem ATX

About the ReadySystem ATX

The ReadySystem™ ATX products are intended for users of turn-key embedded systems, who prefer long lifecycle, configuration controlled computers over desktop grade systems with frequently changing motherboards. ReadySystem ATX models feature the ReadyBoard™ single board computer (SBC), from the 400 MHz Celeron™ CPU to the Intel 1.4 GHz Pentium™ M 738 CPU. The desired operating system (OS) is pre-loaded onto the internal 40 GB (or greater) 2 ½" hard disk drive (HDD). Just load your application software and you are ready to use your system applications.

Using this Guide

This guide provides the most efficient way to set up your ReadySystem ATX with your desired Operating System (OS). The instructions provided in this guide include:

- Removing the ReadySystem ATX from the shipping container and inventorying the accessories
- Connecting peripherals to the ReadySystem ATX
- Powering up the ReadySystem ATX

Information not provided in this Users Guide includes:

- ReadyBoard model specifications
- Environmental requirements
- ReadyBoard model connector/pin numbers and definitions
- Operating System (OS) programming, or operating instructions

NOTE

Refer to the specific Ampro OS manual or the OS manufacturer's manual for instructions when the using the OS software.

Requirements

The following peripherals and devices are needed to make full use of the ReadySystem ATX.

- Peripherals (Customer provided):
 - ◆ PS/2 Keyboard and PS/2 Mouse
 - ◆ CRT Monitor
- Optional Devices/Connections (Customer provided):
 - ◆ Ethernet (LAN) connection
 - ◆ USB Devices, including a keyboard and mouse
 - ◆ Up to two PC/104 expansion modules

What's in the Box

The Contents List identifies items in the shipping container for the ReadySystem ATX QuickStart Kit. The production quantities of the ReadySystem ATX, except for the first of multiple boxes, will not contain the optional items listed for the QuickStart kit, but all boxes will have the standard items such as the mounting hardware, PS/2 Y-cable, and power cords. See Figure 1-1.

Setup Steps

It is important to follow the setup steps in this section in the exact order listed here, but skip any steps that do not apply to your situation. References are provided to chapters within this guide or other Ampro manuals for more information about installation and use of this ReadySystem.

Preparations

1) Open shipping box	<ul style="list-style-type: none"> • Locate the ReadySystem ATX Contents List. See Figure 1-1. • Unpack the contents of the shipping box.
2) Verify Contents	<ul style="list-style-type: none"> • Verify the contents of the shipping box against the Contents List included with your ReadySystem ATX shipping box. • If anything is missing or damaged, call your sales representative or Tech Support. Refer to Appendix A for contact information.
3) Support Documentation (ReadyBoard model Documentation and Support Software (Doc & SW) CD-ROM located in the first QuickStart Kit)	<p><i>ReadySystem ATX Users Guide</i></p> <p>This document describes how to setup and power up the ReadySystem ATX, and is provided on the ReadyBoard model Doc & SW CD-ROM as a PDF file.</p>
	<p><i>ReadyBoard Model Reference Manual</i></p> <p>This document describes the ReadyBoard model used in the ReadySystem ATX and provides detailed reference information for your ReadyBoard and is located on the ReadyBoard model Doc & SW CD-ROM as a PDF file.</p>
	<p><i>ReadyBoard Model QuickStart Guide</i></p> <p>This document describes how to setup, install, and power up the ReadyBoard model installed inside the ReadySystem 2U enclosure and is located on the ReadyBoard model Doc & SW CD-ROM as a PDF file.</p>
	<p><i>Operating System Manual(s)</i></p> <p>These documents describes how to use the desired operating system (OS) with the ReadySystem ATX and provide more detailed programming and operating information. These documents may or may not be provided with ReadySystem ATX depending on the specific licensing requirements.</p>

Setting Up the Workspace

CAUTION To prevent damage to the ReadySystem, ensure there is sufficient clearance around the air vents for unrestricted airflow, especially the power supply vent holes.

The air temperature inside the enclosure can rise above the specified air temperature, if the airflow through the vents is restricted.

4) Select workbench location	<ul style="list-style-type: none"> • The workbench location should be a flat clean surface for setup and operation (including the connection of any external peripherals and optional devices). • Ensure there is sufficient airflow clearance around the entire enclosure.
5) Unpack the ReadySystem ATX	<ul style="list-style-type: none"> • Remove the ReadySystem ATX from its shipping container and place it on a flat work surface. <p>The ReadyBoard model, installed SODIMM, installed internal 40 GB HDD (2 ½"), and the desired OS are pre-installed and tested prior to shipment as the ReadySystem ATX, which is a complete assembly ready for operation.</p>

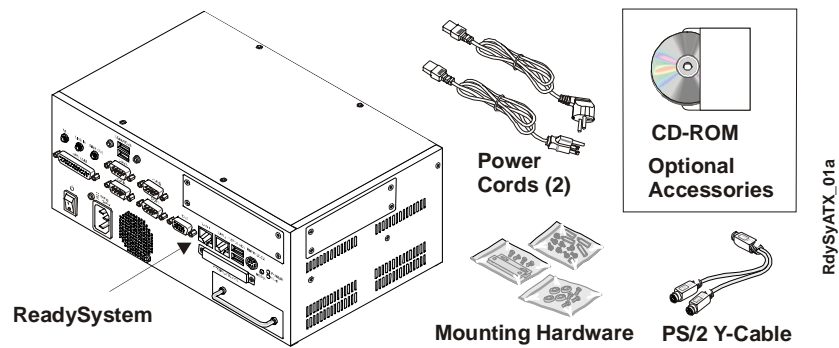

Figure 1-1. ReadySystem ATX Accessories

Installing the Mounting Hardware

- | | |
|---|--|
| <p>6) Connect the appropriate mounting hardware</p> | <ul style="list-style-type: none"> • If necessary, connect the mounting hardware for surface or wall mounting to the bottom or rear of the ReadySystem. See Figure 1-2. The four plastic feet are mounted prior to shipment and will protect the paint finish on the bottom of the enclosure. |
|---|--|

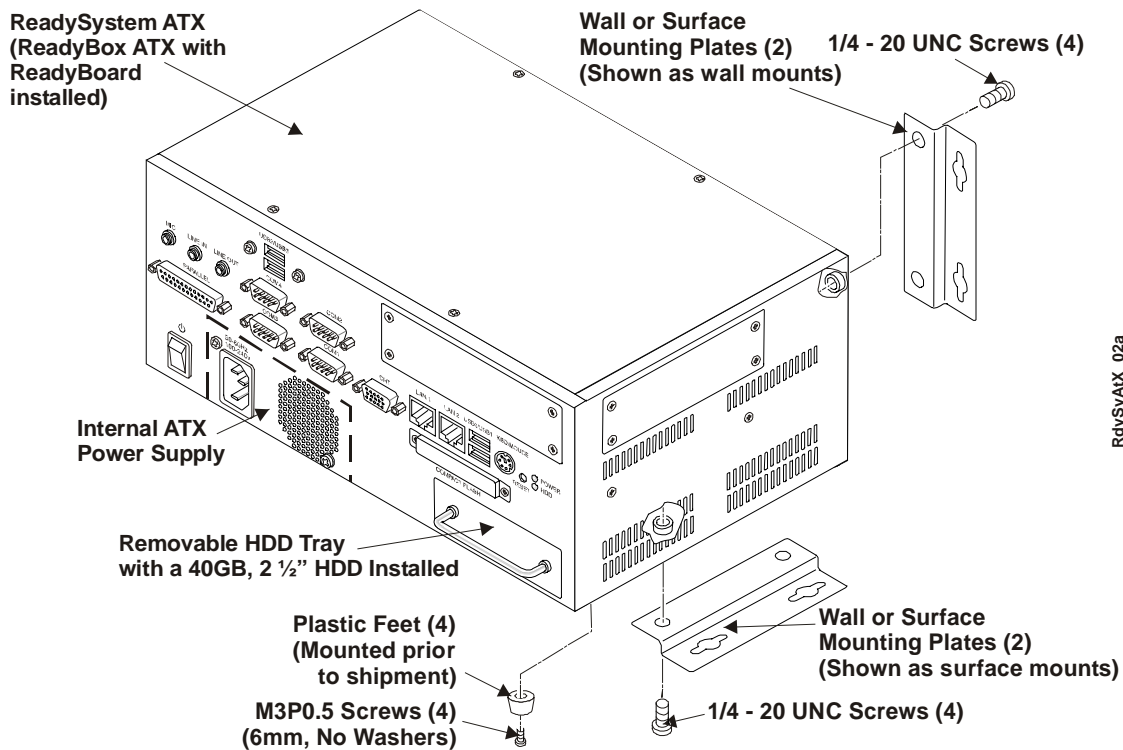
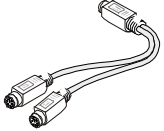

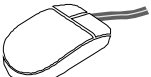
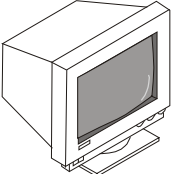

Figure 1-2. Installing the Mounting Hardware

CAUTION

To prevent damage to the internal ATX power supply, do not mount the ReadySystem ATX so that the I/O panel is facing down. This could lead to inadequate airflow and cause damage to the power supply.

Connecting the Peripherals

<p>7) Connect the Y-cable and the respective peripheral cables/devices</p>	<ul style="list-style-type: none"> This includes the Y-cable for the PS/2 keyboard & mouse. <p>Refer to Figure 1-3 and Table 1-1 for the location and description of the connectors and controls.</p>
	<ul style="list-style-type: none"> Connect the PS/2 Keyboard & Mouse Y-cable assembly to the Keyboard/Mouse port on the ReadySystem I/O Panel. See Figure 1-3. <p>This cable assembly provides two connectors for the PS/2 Keyboard and PS/2 Mouse shared port with icons for the specific device.</p>
	<ul style="list-style-type: none"> Connect the keyboard to the free Y-cable connector with the keyboard icon on it.
	<ul style="list-style-type: none"> Connect the PS/2 mouse to the Y-cable connector with the respective mouse icon located on it.
	<ul style="list-style-type: none"> Connect the CRT monitor, using its 15-pin video cable, to the CRT (VGA) connector on the I/O Panel of the ReadySystem. See Figure 1-3.

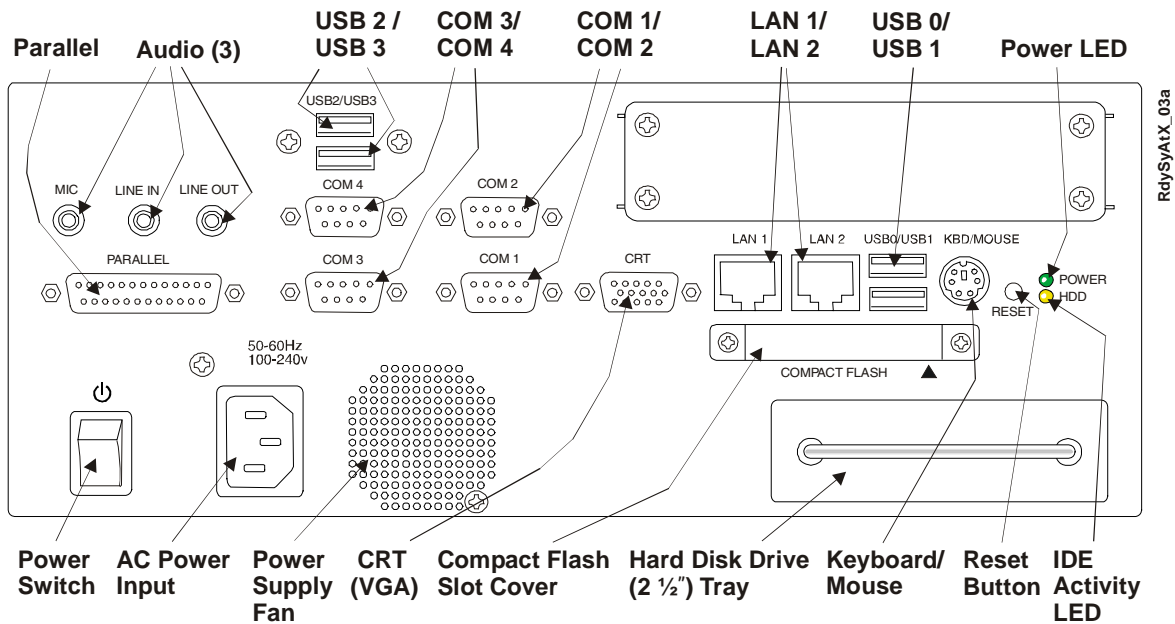

Figure 1-3. I/O Panel Controls and Connectors

NOTE ReadyBoard models with only one Ethernet connector (LAN 1) have a cover over the LAN 2 Port.

Table 1-1. ReadySystem ATX I/O Panel Connectors, Controls, and Indicators

Control/Connector	Description
Power Switch	Use this momentary push button Power Switch to turn on the AC power and has an internal 2-wire cable and 5-pin connector connected to the ReadyBoard..
AC Power In	Use this 3-prong connector for a standard AC input power connection. The internal ATX power supply accepts 100-to-240 VAC, +/- 10% @ 50/60 Hz.
CRT (VGA)	Use this standard 15-pin (DB15) connector for the CRT video connection. This connector is provided on the ReadyBoard.
Keyboard/Mouse	Use this PS/2 connector for the Keyboard and Mouse connected through the required the PS/2 Y-cable adapter provided in the ReadySystem ATX QuickStart Kit or shipping container. The Y-cable has icons on each cable for the respective mouse or keyboard connection. This PS/2 connector is on the ReadyBoard.
USB 0 & 1	Use these two USB connectors (4-pin connectors) for the first two USB devices connected to the ReadySystem.
USB 2 & 3	Use these two USB connectors (4-pin connectors) for the any additional USB devices connected to the ReadySystem. These USB connectors and the respective internal cables are connected to the ReadyBoard installed inside the enclosure.
LAN 1 (Ethernet 1)	This Ethernet port is used for the 10/100BaseT Ethernet connection (8-pin RJ45 connector) and is provided on the ReadyBoard.
LAN 2 (Ethernet 2)	This Ethernet port is typically used for the Gigabit Ethernet (10/100/1000BaseT) connection, if provided on the ReadyBoard model (10-pin RJ45 connector). If not, it uses the standard 8-pin RJ45 connector for 10/100BaseT Ethernet. This connector is provided on the ReadyBoard, if the ReadyBoard model has two Ethernet ports. If it does not, this port is covered for single Ethernet models.
COM 1 & COM 2 (Serial 1 & Serial 2)	Use these two serial ports (DB9, 9-pin) for the standard RS-232 connections to the ReadySystem ATX. These two connectors are provided on the ReadyBoard.
COM 3 & COM 4 (Serial 3 & Serial 4)	Use these two serial ports (DB9, 9-pin) for the standard RS-232 and RS-485/RS-422 connections to ReadySystem. These two serial ports and the respective internal cables are connected to the ReadyBoard installed inside the enclosure.
Parallel	Use this printer port (DB25, 25-pin) connector for any printer you may wish to connect to the ReadySystem. This printer port and its internal cable are connected to the ReadyBoard installed inside the enclosure.
Audio: MIC, Line In, Line Out	Use these three Audio In/Out connectors for the standard Stereo In/Out and MIC in connections to the ReadySystem. These Audio connectors and the respective internal cable are connected to the ReadyBoard installed in the enclosure.
Power-On LED	This green power-on indicator, located on the ReadyBoard, glows when power is turned on and goes dark when power is turned off to the ReadySystem.
HDD Activity LED	This yellow activity indicator, located on the ReadyBoard, flickers when there is I/O activity for the IDE HDD or compact flash card used with the ReadySystem.
Reset Button	Press this reset button momentarily (located on the ReadyBoard) to reset the ReadySystem (hard reset).
Compact Flash Cover and Slot	The compact flash (CF) card goes through the slot opening (not shown) in the I/O panel of the ReadySystem, if installed. The compact flash socket is provided on the underside of the ReadyBoard installed inside the enclosure.
Hard Disk Drive Tray (2 ½")	The HDD tray assembly holds a 40 GB (or greater), 2 ½" hard disk drive (HDD) installed inside the enclosure and connected to the ReadyBoard.

NOTE

If you wish to connect a floppy disk drive (FDD) or CD-ROM to the ReadySystem ATX, you can use one of the USB ports to connect the device.

Applying Power to the ReadySystem ATX

8) Power up the ReadySystem ATX	<ul style="list-style-type: none"> • Connect the supplied power cord into the AC input power connector of ReadySystem. See Figure 1-3. • Plug the CRT monitor's power cord into an AC outlet, and turn on the monitor. See Figure 1-3. • Plug the ReadySystem ATX power cord into an AC outlet. • Press the ReadySystem's momentary power switch (\approx 1 sec) before continuing. See Figure 1-3 and Table 1-1.
9) Verify the ReadySystem ATX powers on satisfactorily	<ul style="list-style-type: none"> • If you want to enter the BIOS Setup before the operating system (OS) starts to load, Press the key during POST at the prompt. Use BIOS Setup during the initial boot to set the desired options (time and date, etc.). • You should see POST complete successfully before the OS (operating system) starts to load. If you are using Linux, the boot loader will appear first, similar to the one shown below with the desired OS name displayed. <div data-bbox="495 756 1315 871" style="border: 1px solid black; padding: 5px;"> <p>NOTE The 40 GB (or greater) hard disk drive (2 ½") installed in the ReadySystem ATX comes with three partitions for the operating system (OS) and swap space..</p> </div>

(The Linux 2.6 OS is shown as an example.)

GNU GRUB version 0.95 (632k lower/250768 upper memory)

Fedora Core (2.6.9-xxx)

GRUBscrn05

Use the ↑ and ↓ keys to select which entry is highlighted.
Press Enter to boot the selected OS, 'e' to edit the commands before booting, 'a' to modify the kernel arguments before booting, or 'c' for a command-line.

NOTE The GNU GRUB boot loader screen will continue to display indefinitely, unless you execute one of the listed options.

10) Using the Operating System (OS)	<ul style="list-style-type: none"> • You should see a prompt of some kind indicating the OS is loading, or has loaded, as you view the screen at this point. • If you are required to log into the OS, use <i>root</i> for the admin name and <i>software</i> as the password to log on. If you are logging in as a normal user, use <i>software</i> for the name and password. • Refer to the desired OS manual (Ampro's or OS Manufacturers), that may or may not be provided with the ReadySystem, (depends on licensing agreements) for more information. • If you require drivers not installed on the HDD (2½") located inside the ReadySystem, refer to ReadyBoard model Doc & SW CD-ROM for additional drivers and instructions.
-------------------------------------	--

Chapter 2 Installing ReadySystem ATX Options

The procedures in this chapter describe how to install/remove the ReadySystem ATX supported options. This includes removing/installing the compact flash card and its cover, as well as removing the ReadyBoard model SBC from the ReadySystem ATX enclosure and removing/installing memory.

NOTE	<p>The ReadyBoard 700 is used in these ReadyBoard ATX examples, but you will need to refer to the specific documentation referenced here for your specific ReadyBoard model to locate and identify the jumper and connector locations that apply to your specific ReadyBoard model.</p> <p>Refer to the ReadyBox ATX Users Guide, ReadyBoard model QuickStart Guide, or the ReadyBoard model Reference Manual for more specific installation/removal information than is provided in this Chapter.</p>
-------------	--

Compact Flash Card Installation

This brief procedure describes how to remove the protective cover over the compact flash opening and installing the compact flash card into the slot opening provided in the I/O panel. Refer to the ReadyBoard model documentation for specific compact flash jumper settings and compatibility.

CAUTION	<p>To prevent system hangs when using older compact flash cards on the same IDE channel as UDMA 100 IDE hard disk drives, ensure your compact flash is compatible with the UDMA 100 IDE drives. Consult with your compact flash card vendor for UDMA 100 compatibility. You may use Type I or II compact flash cards from commercially available suppliers.</p>
----------------	---

Tools Required

Use these tools to remove and install the compact flash card into or out of the ReadySystem.

- Small to medium Phillips screwdriver
- Anti-static service kit - Use a complete anti-static service kit (or the equivalent) to remove or install the compact flash card. A complete anti-static service kit should include a static-dissipating work surface, a chassis clip lead, and a wrist or ankle strap.

Installing the Compact Flash Card

1. Compact flash (CF) card installation preparation:
 - ♦ If the ReadySystem is already prepared for compact flash installation, including removal of the CF cover, with power turned off and the power cord disconnected, skip to Step 5.
 - ♦ If the ReadySystem power is connected and operating, continue with next step.

CAUTION	<p>To prevent damage to the ReadyBoard or the compact flash card, ensure the power switch on the ReadySystem is turned off and the power cord has been removed from the AC power source. The ATX power supply will continue to provide standby current to the enclosure until the power cord is disconnected.</p>
----------------	---

2. Initiate a shut down sequence through the OS, or hold the power switch in for 4-6 seconds to turn power off.

The Power LED should turn off completely when the power is turned off.

3. Disconnect the power cord from the AC power source.

CAUTION

To prevent damage to the ReadyBoard or the compact flash card, ensure you are discharging yourself and following good Electrostatic Discharge principals before touching either one. The ReadyBoard and the compact flash card are sensitive to static electricity and can be easily damaged by improper handling. Do the following when handling either one:

Always use an anti-static wrist/ankle strap and a grounding mat.

Leave the compact flash in the anti-static bag until you are ready to install it.

Before you remove a compact flash card from the anti-static bag, touch a grounded, unpainted metal surface to discharge any static electricity.

4. Use a Phillips screwdriver to remove the compact flash cover and place the two screws in a safe place for use later. See Figure 2-1.
5. If necessary, inspect the socket for bent pins or debris on the pins of the compact flash socket.
6. Remove the compact flash card from its protective bag, handling the compact flash card by its edges.

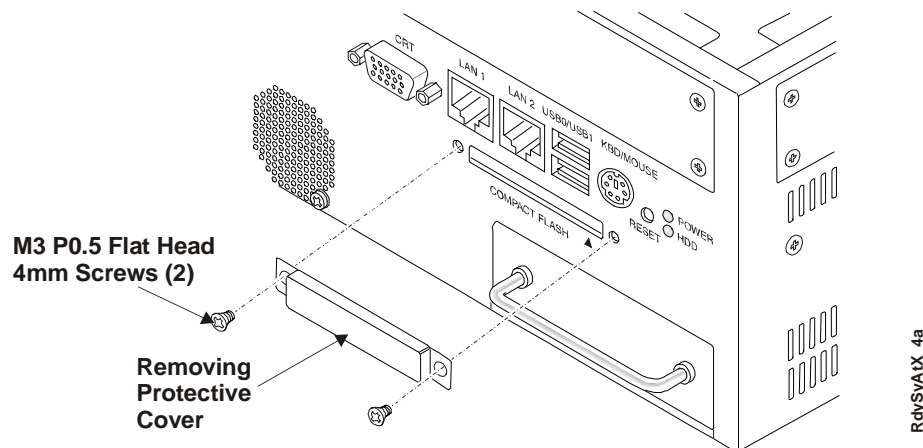

Figure 2-1. Removing Compact Flash Protective Cover

CAUTION

To prevent damage to the ReadyBoard and compact flash card, do not force the compact flash card into the slot. If you have to force the compact flash card into the slot, it is not installed correctly.

The compact flash sockets on the ReadyBoard series have enough flexibility in the socket to expand when the CF is installed incorrectly.

7. Insert the compact flash card into the opening provided by matching the pin-1 orientation of the compact flash card with the arrowhead on the I/O panel. See Figure 2-2.

NOTE The keyed slots and lip (or catch edge) on the compact flash card are used to install into the socket in only one orientation. Pin-1 one should be down and to the right as shown in the Figure 2-2.

8. Push the compact flash card into the opening until it is firmly into the socket and mates with the pins. See Figure 2-2.

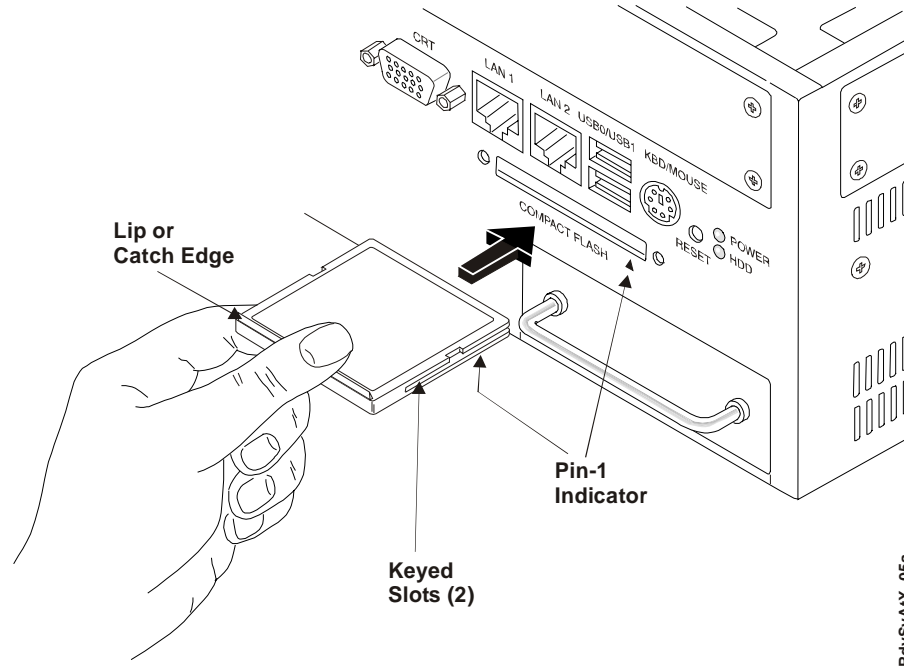

Figure 2-2. Installing the Compact Flash Card

9. If your application or environment requires protection of the compact flash card, for security or EMI value, you can re-install the protective cover over the compact flash card. See Figure 2-1. Reconnecting the protective cover will provide full EMI protection.
10. Refer to the ReadyBoard QuickStart Guide for any required jumper settings for the compact flash card, before restoring power to the ReadySystem.

Removing the Compact Flash Card

To remove the compact flash card from the ReadySystem enclosure opening, simply reverse the installation procedure and follow all of the safety precautions listed.

ReadySystem ATX Disassembly/Reassembly

Accessing the bottom of the ReadyBoard, where the SODIMM memory is installed, requires removing the ReadyBoard from the ReadySystem ATX enclosure. The following procedures describe how to remove from and re-install the ReadyBoard into the ReadySystem ATX enclosure.

Tools Required

The following tools are needed to remove and install the ReadyBoard SBC from or into the ReadySystem ATX enclosure.

- Small to medium Phillips screwdriver
- Use a complete anti-static service kit (or the equivalent) to remove or install the SODIMM onto the ReadyBoard. A complete anti-static service kit should include a static-dissipating work surface, a chassis clip lead, and a wrist or ankle strap.

Removing the ReadyBoard from Enclosure

CAUTION	To prevent damage to the ReadyBoard SBC, ensure power in the ReadySystem is turned off and the power cord has been removed from the AC outlet. The ReadySystem power supply will continue to provide standby current to the enclosure until the power cord is disconnected.
----------------	---

1. Prepare the ReadySystem ATX enclosure for ReadyBoard removal:
 - ◆ If the ReadySystem is already prepared for ReadyBoard removal, with the power turned off, power cord disconnected, top cover removed and all the cables disconnected, skip to Step 8.
 - ◆ If the ReadySystem is powered and operating, continue with the next step.
2. Initiate a shut down sequence through the OS, or hold the power switch in for 4-6 seconds to turn power off. See Figure 1-3.

The Power LED should turn off completely when the power is turned off.
3. Remove the power cord from the AC outlet.

CAUTION	To prevent damage to the Top Cover after removing the seven screws, you must slide the top cover to the left before lifting the Top Cover off the enclosure, due to the Z-Bracket Lip.
----------------	--

4. Remove the seven screws holding the top cover to the ReadySystem enclosure and then slide the cover to the left as shown in the Figure 2-3.
5. If you have installed, or your ReadySystem ATX was shipped with PC/104 expansion board(s) connected to the ReadyBoard, you will need to disconnect and remove these PC/104 boards from the ReadyBoard before removing it from the enclosure.

Refer to the respective manuals for the PC/104 expansion boards to disconnect and remove these PC/104 boards.

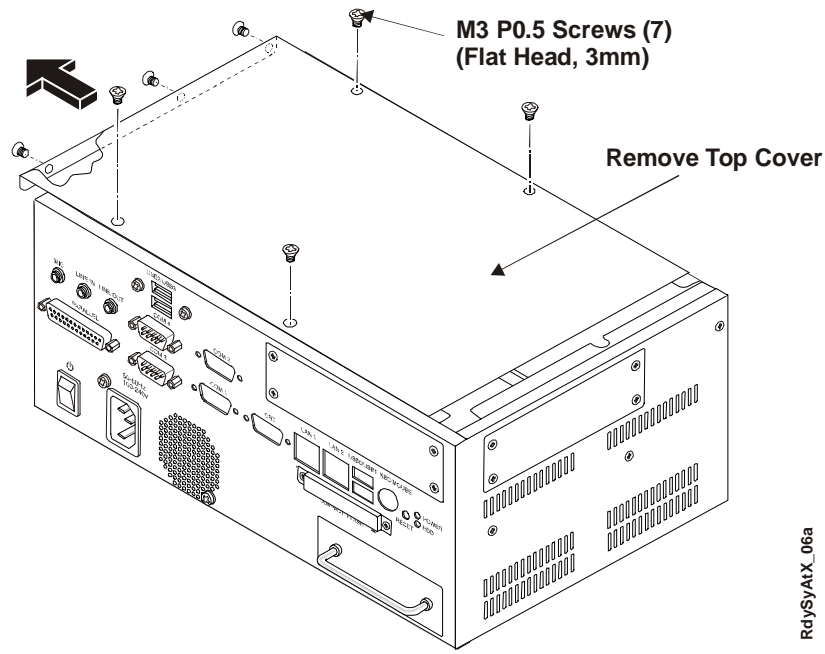

Figure 2-3. Removing the ReadySystem ATX Top Cover

6. You may disconnect the cables to the ReadyBoard in any order, but do so carefully. See Figures 2-4, 2-9, and 2-10 for connector assignments.
7. Lay the free ends of cables aside and out of the way for re-assembly later. See Figure 2-6.

The parallel/floppy cable and the IDE cable must remain under or near the board location and near the connectors on the board when disconnected.

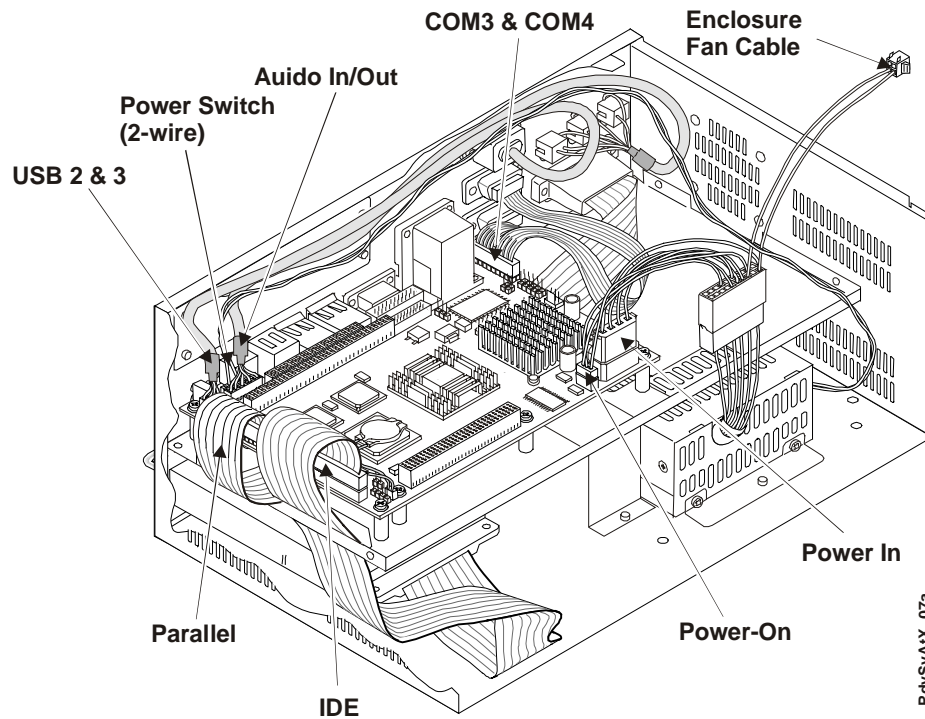

Figure 2-4. Disconnecting the Cables

CAUTION To prevent damage to the static sensitive components on the ReadyBoard, ensure you follow good Electrostatic Discharge principles. Components on the ReadyBoard are sensitive to static electricity and can be easily damaged by improper handling. Do the following when handling the ReadyBoard:

Always use an anti-static wrist/ankle strap and a grounding mat.

Before you handle the ReadyBoard, touch a grounded, unpainted metal surface to discharge any static electricity.

- Remove the four to eight screws holding the ReadyBoard to the inside of the enclosure. See Figure 2-5.

If there are PC/104 expansion board(s) still connected to the ReadyBoard that you have not removed yet, you will need to disconnect and remove these PC/104 boards from the ReadyBoard before removing it from the enclosure. Refer to the respective manuals for the PC/104 expansion boards to disconnect and remove these PC/104 boards.

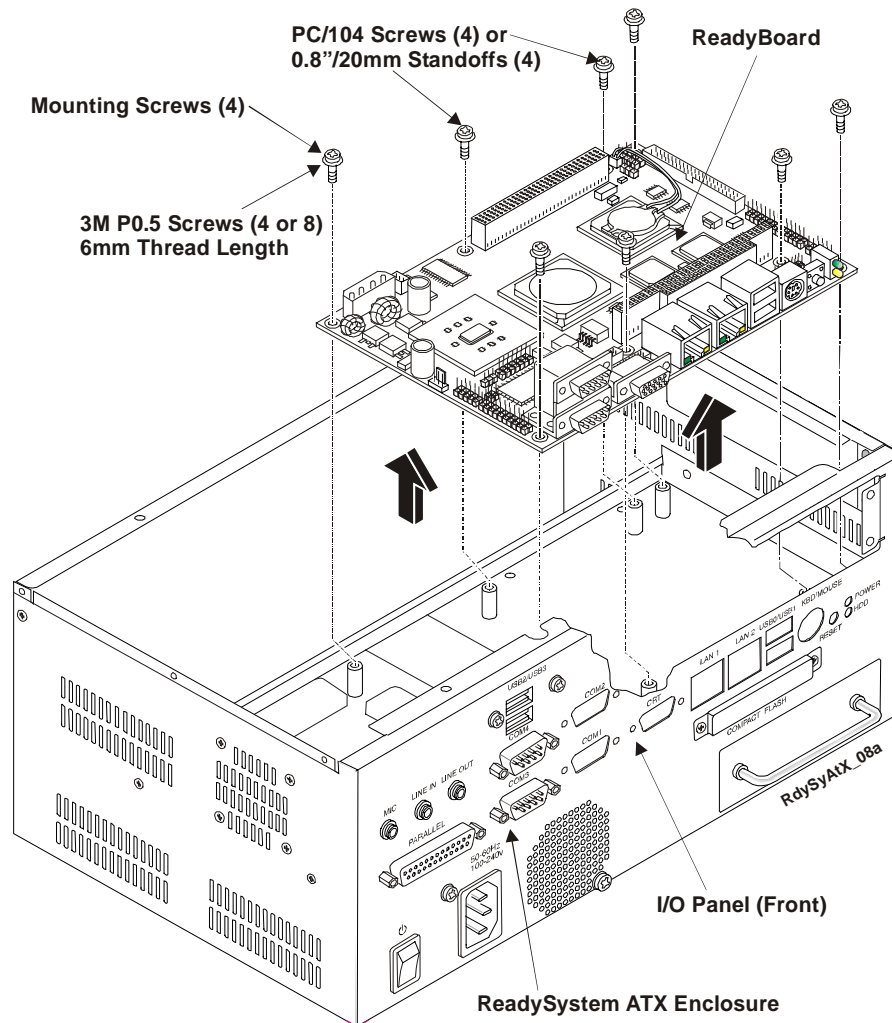

Figure 2-5. Removing ReadyBoard from Enclosure

- Once you have removed all of the screws (and PC/104 boards) slowly work the ReadyBoard out of the enclosure until it is safely clear and place it on a protective surface. See Figure 2-5.

Installing the ReadyBoard

1. Prepare the ReadySystem ATX enclosure and ReadyBoard for installation.
 - ◆ If the ReadySystem enclosure is already prepared for ReadyBoard installation, with the top cover removed, the parallel cable in the correct position, and the power cord disconnected, skip to Step 5.

This includes installing the correct size SODIMM onto the ReadyBoard, since you will not have access to the SODIMM socket once the ReadyBoard is installed into the enclosure.
 - ◆ If the ReadySystem is not ready for the ReadyBoard installation, continue with the next step.

CAUTION	To prevent damage to the ReadyBoard, ensure the power cord has been removed from the power source. The ATX power supply inside the ReadySystem will continue to provide standby current to the connectors until the power cord is disconnected.
----------------	---

2. Ensure the power cord is still disconnected from the AC power source.

CAUTION	To prevent damage to the Top Cover after removing the screws, you must slide the top cover to the left before lifting the Top Cover off the enclosure, due to the Z-Bracket Lip.
----------------	--

3. If the top cover was replaced with a few screws holding it in place, remove all the screws holding it in place and then slide the cover to the left as shown in Figure 2-3.
4. Move the internal cables out of the way to allow installation of the ReadyBoard. See Figure 2-6.

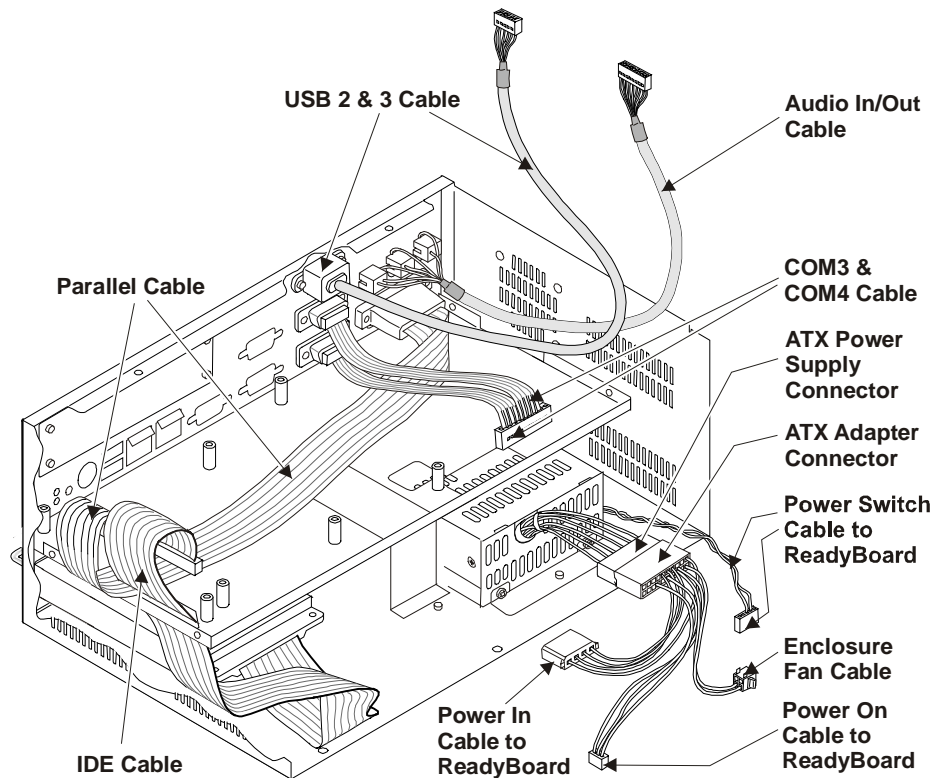

Figure 2-6. Internal Cables Shown Separated

5. Position the ReadyBoard near the eight standoffs on the enclosure shelf at about a 10° angle to the mounting shelf. See Figures 2-7 and 2-8.

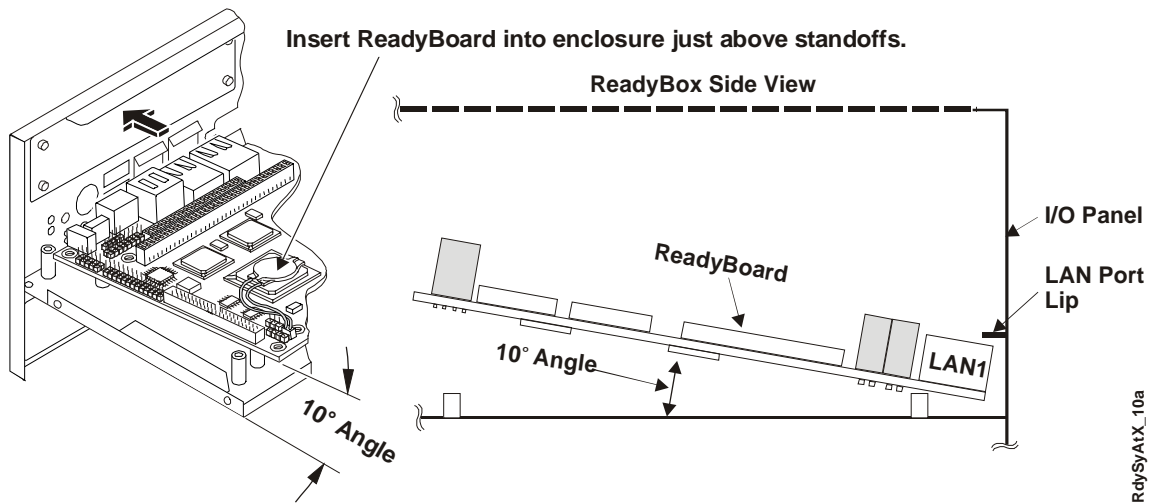

Figure 2-7. ReadyBoard Positioned Under LAN Ports

Notes: Use screws (4) with washers if not adding any PC/104 modules to ReadyBoard.

Use 0.8"/20 mm Standoffs (4) for first PC/104 Board.

Use 0.6"/15 mm Standoffs (4) for second PC/104 Board.

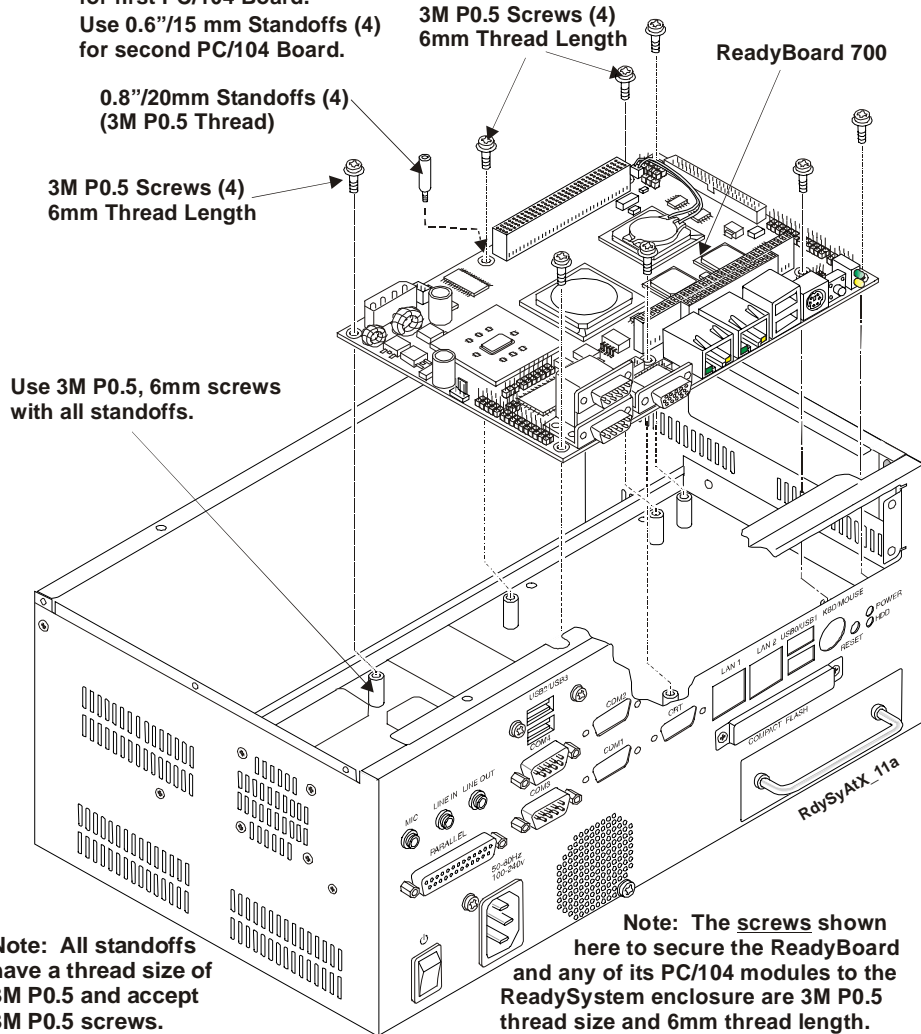

Figure 2-8. Installing ReadyBoard into Enclosure

6. Insert the ReadyBoard and its Ethernet connectors just under the lip of the two LAN ports on the enclosure wall, behind the I/O panel. See Figure 2-7.
7. Slowly work the ReadyBoard into place, inserting the I/O connectors and LEDs into the respective openings on the I/O Panel.

When you have the ReadyBoard in position you should clearly see the mounting holes for the eight standoffs under the board mounting holes, and the LEDs should fit into the openings provided on the I/O Panel.

8. Insert four M3 P0.5 6 mm screws with washers, into the standoffs on the enclosure shelf at the four corners of the board. See Figure 2-8.
9. If you are putting PC/104 board(s) onto the ReadyBoard, insert the four 0.8" (20 mm) standoffs provided with the ReadyBoard at the four PC/104 mounting locations. See Figure 2-8.
 - ◆ Insert four M3 P0.5 6 mm screws with washers at the four PC/104 mounting locations on the first expansion board, if you are not installing a second PC/104 expansion board. See Figure 2-8.
 - ◆ If you are putting a second PC/104 expansion board onto the ReadyBoard, insert the four 0.6" (15 mm) standoffs on the first PC/104 expansion board provided with the expansion board at the four PC/104 mounting locations. See Figure 2-8.
 - ◆ Insert four M3 P0.5 6 mm screws with washers at the four PC/104 mounting locations on the top expansion board.
10. If you are not putting any PC/104 board (s) onto the ReadyBoard, insert four M3 P0.5 6 mm screws with washers at the four PC/104 mounting locations on the ReadyBoard. See Figure 2-8.
11. Go to the next procedure to connect the cables.

Connecting the Cables

When connecting the cables refer to the pin-1 designations shown in the Figure 2-10. Pin-1 is shown as a black pin (round or square) at the connectors and jumpers, unless otherwise noted. If you desire more installation information than is provided in this guide refer to the ReadyBox ATX Users Guide or the ReadyBoard model QuickStart Guide.

1. Connect the Parallel cable to the Parallel/Floppy connector (J20). See Figures 2-4, 2-9, and 2-10.
2. Connect the IDE cable to the IDE connector (J22). See Figures 2-4, 2-9, and 2-10.

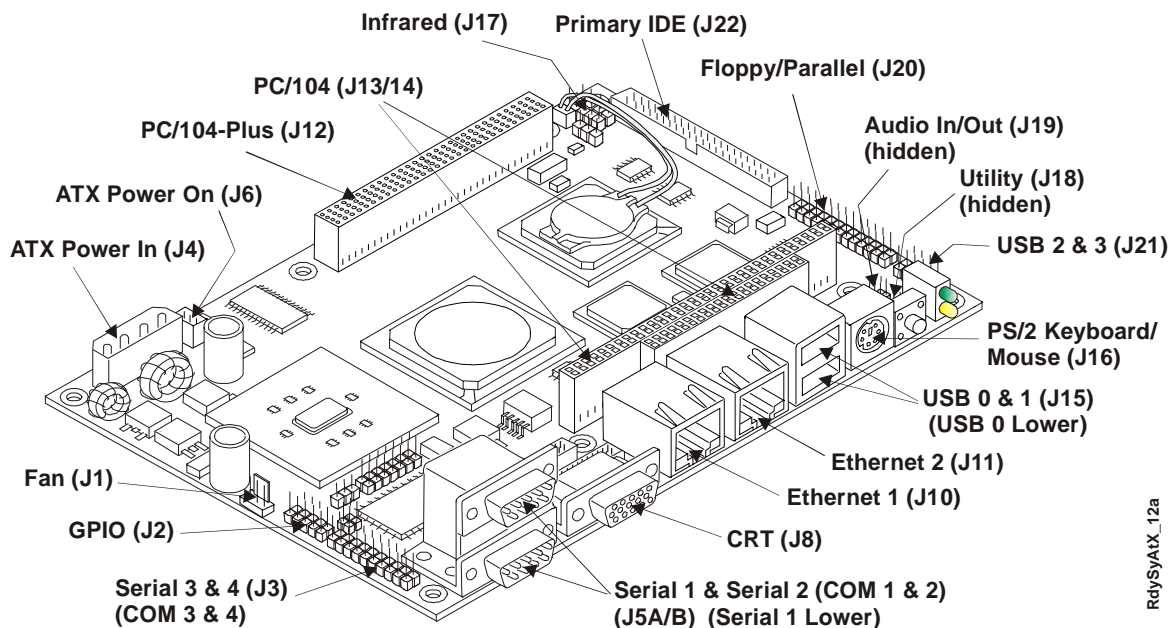

Figure 2-9. Connector Locations (Typical ReadyBoard)

RdySysATX_12a

3. Connect the USB 2 & 3 cable to the USB 2 & 3 connector (J21). See Figures 2-4, 2-9, and 2-10.
4. Connect Power Switch cable (two-wires) to Utility connector (J18). See Figures 2-4, 2-9, and 2-10.
5. Connect the Audio In/Out cable to the Audio In/Out connector (J19). See Figures 2-4, 2-9, and 2-10.
6. Connect the Serial 3 & 4 cable to the Serial 3 & 4 connector (J3). See Figures 2-4, 2-9, and 2-10.
7. Connect the ATX Power In cable to the Power In connector (J4). See Figures 2-4, 2-9, and 2-10.
8. Connect the power on cable to the Power-On connector (J6). See Figures 2-4, 2-9, and 2-10.

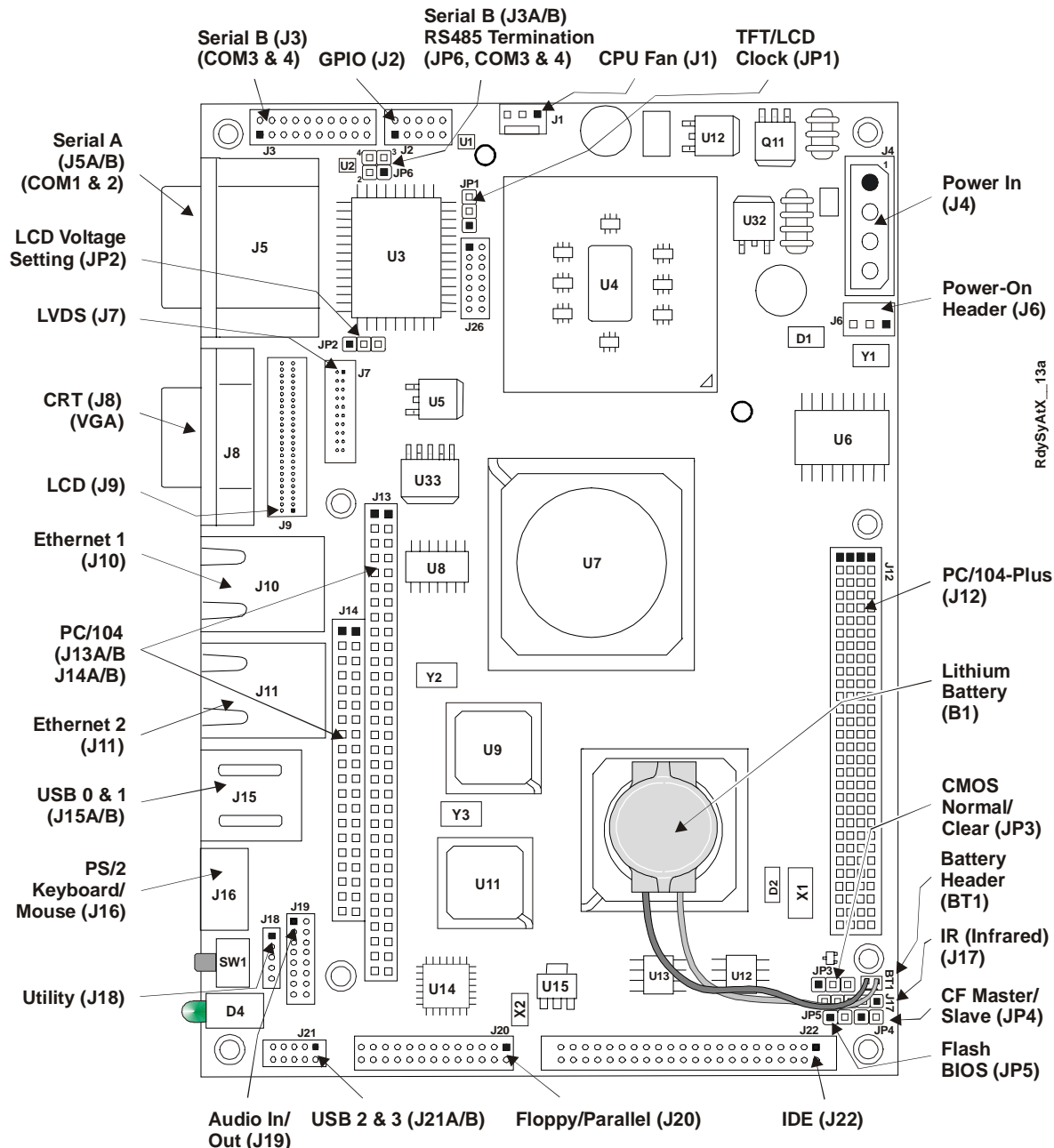

Figure 2-10. Connector Pin-1 Locations (Typical ReadyBoard)

9. You may replace the top cover before restoring powering to check ReadySystem ATX operation, or restore power to check system operation before replacing the top cover to the enclosure.

In either case, observe all safety precautions when replacing the top cover or restoring power to the ReadySystem.

Memory Installation

The ReadyBoard model uses a single SODIMM socket available on the underside of the board. The ReadyBoard SBC must be removed from the ReadySystem ATX enclosure to remove or install the single SODIMM.

NOTE	Refer to the specific ReadyBoard model QuickStart Guide or Reference Manual for SODIMM installation recommendations.
-------------	--

Tools Required

Use an anti-static service kit (or the equivalent) to remove or install the SODIMM. An anti-static service kit should include a static-dissipating work surface, a chassis clip lead, and a wrist or ankle strap.

Installation Guidelines

- When handling a SODIMM, observe anti-static discharge precautions to avoid damage.
- Refer to the specific ReadyBoard model QuickStart Guide or Reference Manual for SODIMM installation recommendations.
- The typical SODIMM sizes are available from Ampro (64MB, 128MB, 256MB, 512MB, or 1GB) depending on the supported memory size of the ReadyBoard model.
- The supported SODIMM memory size is ReadyBoard model specific.

Removing the SODIMM

Use this procedure to remove the SODIMM from the SODIMM socket on the ReadyBoard.

1. Prepare the ReadySystem ATX for SODIMM removal:
 - ◆ If the ReadyBoard model is already prepared for SODIMM removal, with the ReadyBoard removed from the enclosure, then skip to Step 7.
 - ◆ If the ReadySystem is powered and operating, and continue with next step.

CAUTION	To prevent damage to the ReadyBoard model, ensure the ReadySystem ATX power is turned off and the power cord has been removed from the power source. The internal ATX power supply will continue to provide standby current to the board until the power cord is disconnected.
----------------	--

2. Initiate a shut down sequence through the OS, or hold the power switch in for 4-6 seconds to turn power off.

The Power LED should turn off completely when the power is turned off.
3. Remove the ReadySystem ATX power cord from the AC outlet.
4. Remove the seven screws holding the top cover to the ReadySystem ATX enclosure and then slide the cover to the left as shown in the Figure 2-3.
5. Disconnect the cables to the ReadyBoard model and lay the free ends out of the way.
6. Remove the ReadyBoard model from the ReadySystem ATX enclosure and place on an anti-static surface, before continuing with this procedure.

Refer to the procedures for *Removing the ReadyBoard from Enclosure* for more information.
7. Turn the ReadyBoard model over to access the bottom of the board while laying it on a flat anti-static surface. See Figure 2-11.

CAUTION To prevent damage to the SODIMM, do not touch the SODIMM until you have discharged yourself and followed good Electrostatic Discharge principals. The SODIMMs are sensitive to static electricity and can be easily damaged by improper handling. Do the following when handling a SODIMM:

Use an anti-static wrist/ankle strap and a grounding mat connected to ground.

Leave the SODIMM in the anti-static bag until you are ready to install it.

Before you remove a SODIMM from the anti-static bag, touch a grounded, unpainted metal surface to discharge any static electricity.

8. Locate the SODIMM socket (DIMM1) on the bottom of the ReadyBoard model. See Figure 2-11.
9. Open both retaining latches to release the SODIMM from the socket. See Figure 2-11.

The SODIMM will spring up to a 45° angle to the board once you open both retaining latches. If the SODIMM does not spring up to a 45° angle, then the retaining latches have not released the SODIMM from the socket.

10. Using the card edges, lift the SODIMM completely away from the socket. See Figure 2-11.
11. Place the SODIMM on an anti-static surface or in an anti-static bag.

NOTE If you remove the SODIMM and restore power without a SODIMM installed, you will not see a display and your system will not work properly.

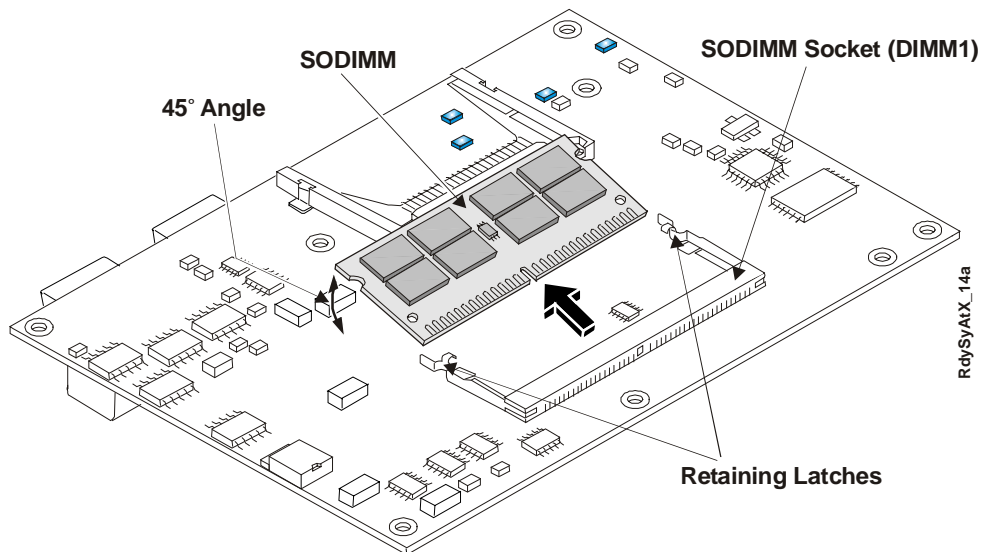

Figure 2-11. Removing SODIMM from Socket

Installing the SODIMM

If you want to install a larger size SODIMM or replace the existing SODIMM, refer to the following procedure.

1. Prepare the ReadySystem ATX for SODIMM installation:
 - ◆ If the ReadyBoard model is already prepared for SODIMM installation, with the ReadyBoard removed from the Ready System enclosure, skip to Step 7. If the SODIMM socket is empty, skip to Step 9.
 - ◆ If the ReadySystem is powered and operating, continue with next step.

CAUTION	To prevent damage to the ReadyBoard model, ensure the ReadySystem ATX power is turned off and the power cord has been removed from the power source. The internal ATX power supply will continue to provide standby current to the board until the power cord is disconnected.
----------------	--

2. Initiate a shut down sequence through the OS, or hold the power switch in for 4-6 seconds to turn power off.

The Power LED should turn off completely when the power is turned off.

CAUTION	To prevent damage to the SODIMM, do not touch the SODIMM until you have discharged yourself and followed good Electrostatic Discharge principals. The SODIMMs are sensitive to static electricity and can be easily damaged by improper handling. Do the following when handling a SODIMM: Leave the SODIMM in the anti-static bag until you are ready to install it. Use an anti-static wrist/ankle strap and a grounding mat connected to ground. Before you remove a SODIMM from the anti-static bag, touch a grounded, unpainted metal surface to discharge any static electricity.
----------------	--

3. Remove the ReadySystem ATX power cord from the AC outlet.
4. Remove the seven screws holding the top cover to the ReadySystem ATX enclosure and then slide the cover to the left as shown in the Figure 2-13.
5. Disconnect the cables to the ReadyBoard model and lay the free ends out of the way.
6. Remove the ReadyBoard model from the ReadySystem ATX enclosure and place it on anti-static surface, before continuing with this procedure.

Refer to the procedures for *Removing the ReadyBoard from Enclosure* for more information.
7. Turn the ReadyBoard model over to access the bottom of the board while laying on a flat anti-static surface. See Figure 2-11.
8. If you need to remove the existing SODIMM from the SODIMM socket before continuing, refer to the previous procedure beginning with Step 9.

Follow Step 9 to 11 in the proceeding procedure, *Removing the SODIMM*, before continuing with the next step in this procedure.
9. Remove the SODIMM from its protective bag, handling the SODIMM by its edges.

NOTE	Refer to the specific ReadyBoard model QuickStart Guide or Reference Manual for SODIMM installation recommendations.
-------------	--

10. Ensure there is nothing in the SODIMM socket that would prevent its installation.
11. Insert the SODIMM into the socket at 45° angle to the bottom of the ReadyBoard model with the components facing up. See Figure 2-12.

The SODIMM card edge and socket are keyed to install into the socket with only one orientation.

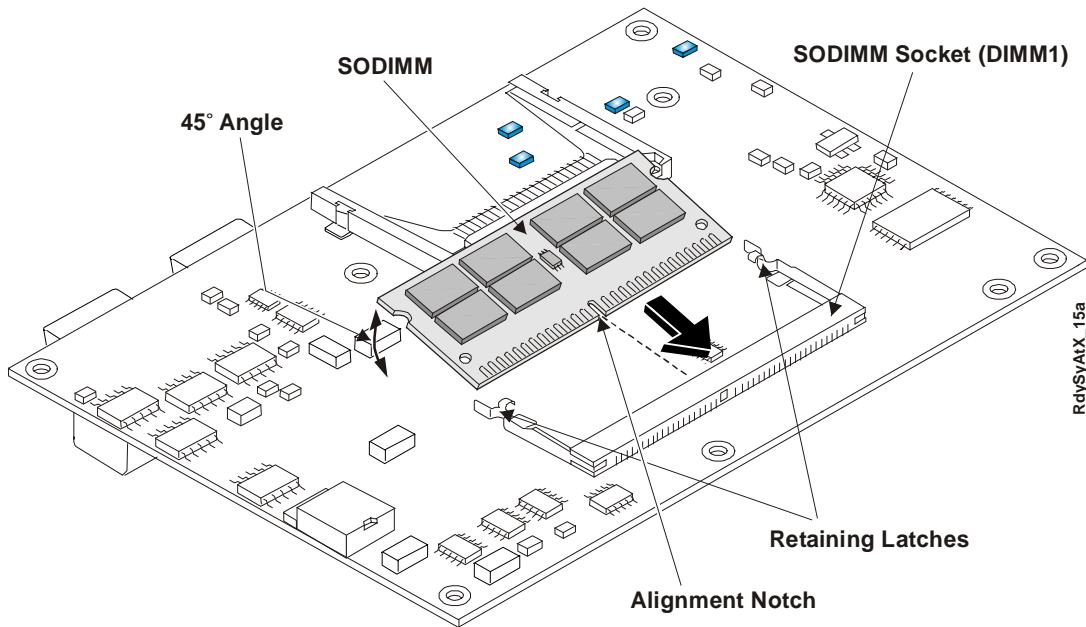

Figure 2-12. Installing SODIMM into Socket

12. Press the edges of the SODIMM down between the latches, until the latches snap into place. See Figure 2-12.

The latches should open to accept the SODIMM without any resistance. If you encounter any resistance, you may not have inserted the SODIMM far enough into the socket.

13. If the retaining latches do not close completely on the SODIMM, remove it and repeat Steps 10 to 12.
14. Reinstall the ReadyBoard model into the ReadySystem ATX enclosure.
Refer to the *Installing the ReadyBoard* procedure for more information.
15. Reconnect the cables to the ReadyBoard model.
Refer to the *Connecting the Cables* procedure for more information.
16. Restore power to the ReadySystem ATX and observe the boot screen for new memory recognition.
If the system does not boot or there is a problem recognizing the new memory, the new SODIMM could be defective or the SODIMM was not properly installed or recognized.

Appendix A Technical Support

Ampro Computers, Inc. provides a number of methods for contacting Technical Support as listed in Table A-1 below. Requests for support through the Virtual Technician are given the highest priority, and usually will be addressed within one working day.

- Ampro Virtual Technician – This is a comprehensive support center designed to meet all your technical needs. This service is free and available 24 hours a day through the Ampro web site at <http://ampro.custhelp.com>. This includes a searchable database of Frequently Asked Questions, which will help you with the common information requested by most customers. This is a good source of information to look at first for your technical solutions. However, you must register online before you can log in to access this service.
- Personal Assistance – You may also request personal assistance by going to the "Ask a Question" area in the Virtual Technician. Requests can be submitted 24 hours a day, 7 days a week. You will receive immediate confirmation that your request has been entered. Once you have submitted your request you can go to the "My Stuff" area and log in to check status, update your request, and access other features.
- Embedded Design Resource Center – This service is also free and available 24 hours a day at the Ampro web site at <http://www.ampro.com>. However, you must be registered online before you can log in to access this service.

The Embedded Design Resource Center was created as a resource for embedded system developers to share Ampro's knowledge, insight, and expertise gained from years of experience. This page contains links to White Papers, Specifications, and additional technical information.

Table A-1. Technical Support Contact Information

Method	Contact Information
Virtual Technician	http://ampro.custhelp.com
Web Site	http://www.ampro.com
Standard Mail	Ampro Computers, Incorporated 5215 Hellyer Avenue San Jose, CA 95138-1007, USA

Appendix B System Overview

This system overview presents general information about the EPIC Architecture and the ReadySystem ATX enclosure (ReadyBox ATX). After reading this chapter you should understand:

- EPIC architecture
- ReadyBox ATX features, including I/O panel and connectors
- ReadyBox ATX specifications
- ReadyBox ATX construction
- ReadyBox ATX mounting dimensions

EPIC Architecture

In 2004, five companies collaborated to fill the void between the EBX size and the PC/104 size with a new industry standard form factor (115 mm x 165 mm, or $\approx 4.5" \times 6.5"$) called "Embedded Platform for Industrial Computing (EPIC)." The EPIC standard principally defines physical size, mounting hole pattern, and power connector locations. It does not specify processor type or electrical characteristics. There are recommended connector placements for serial/parallel, Ethernet, graphics, and memory expansion, including an optional location for PC Card (PCMCIA) expansion. This embedded SBC standard ensures that embedded system OEMs can standardize their designs and that embedded computing solutions can be designed into even more space constrained environments than ever before.

The EPIC standard boasts the same highly flexible and adaptable system expansion as EBX, allowing easy and modular addition of functions such as USB 2.0, Firewire or wireless networking not usually contained in standard product offerings. The EBX system expansion is based on popular existing industry standards, PC/104™, PC/104-Plus™, and PCI-104™. PC/104 places the ISA bus on compact 3.6" x 3.8" modules with self-stacking capability. PC/104-Plus adds the power of a PCI bus to PC/104 while retaining the basic form-factor, but PCI-104 expansion cards only provide the PCI Bus to the PC/104 form-factor. Using PC/104 expansion cards, an EPIC board can be easily adapted to meet a variety of embedded applications.

The EPIC standard also brings stability to the mid-sized embedded board market and offers OEMs assurance that a wide range of products will be available from multiple sources – now and in the future. The EPIC specification is freely available to all interested companies, and may be used without licenses or royalties. For further technical information on the EPIC standard, visit the web site at <http://www.epic-sbc.org>. See Figure B-1.

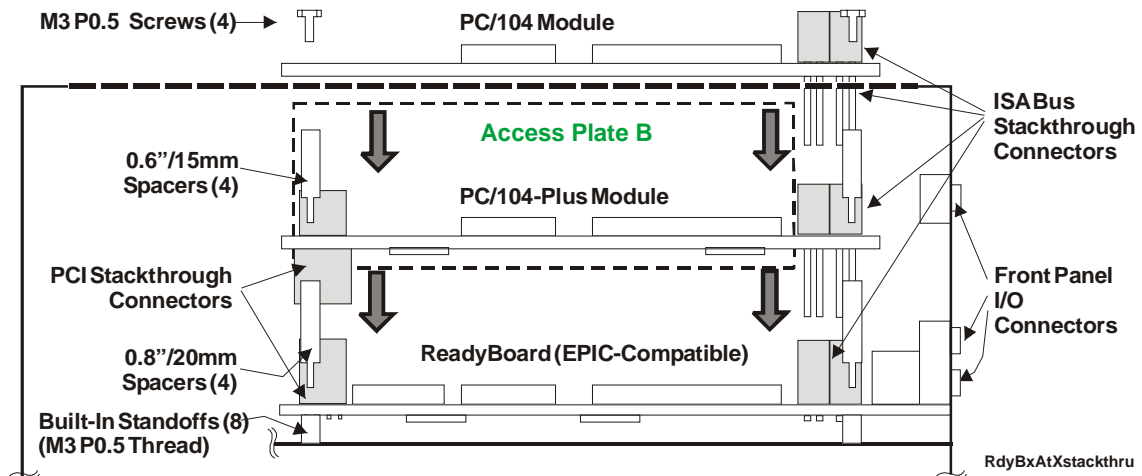

Figure B-1. Stacking PC/104 Modules in ReadyBox ATX (Side view)

Product Description

The ReadyBox ATX is a small enclosure for Ampro's ReadyBoard products and will accept any Ampro ReadyBoard SBC. Embedded systems using the ReadyBox ATX can be expanded through the PC/104, PC/104-Plus, or PCI-104 expansion buses found on Ampro's ReadyBoard SBCs for additional system I/O. These buses offer compact, self-stacking, modular expandability.

The PC/104 bus is an embedded system version of the signal set provided on a desktop PC's ISA bus. The PC/104-Plus bus includes this signal set, and in addition, signals implementing a PCI bus, available on an additional 120-pin (4 rows of 30 pins) PCI expansion bus connector. This PCI bus operates at clock speeds up to 33 MHz. The PCI-104 bus only carries the PCI signal set and is primarily used with PCI-104 compatible expansion boards. The PCI-104 bus can also be used with some PC/104-Plus boards, and with the help of a special expansion ISA bus adapter board (MiniModule ISA) can be used with PC/104 boards.

The ReadyBox ATX is particularly well suited to embedded applications and meets the size, power consumption, temperature range, quality, and reliability demands of many embedded systems.

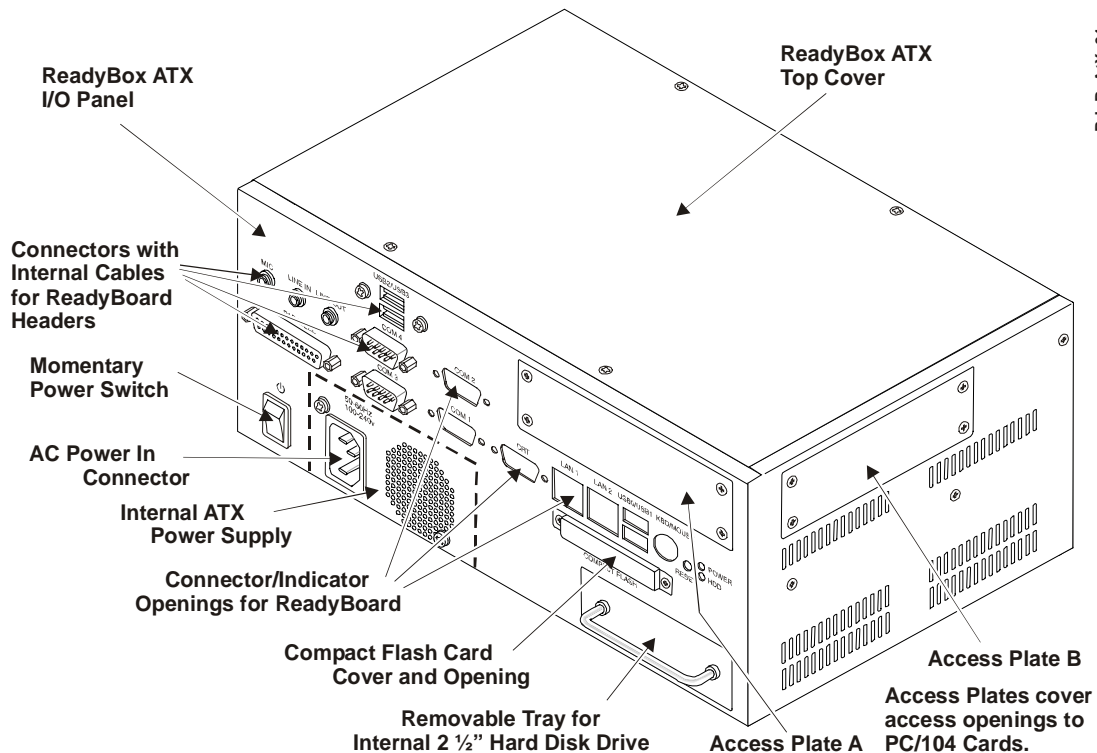

Figure B-2. ReadyBox ATX Enclosure (No ReadyBoard)

ReadyBox ATX Features

- Compact size
- Quiet operation
- Accepts any Ampro ReadyBoard SBC
- Brings all ReadyBoard I/O to a single I/O panel
- Accepts two PC/104 expansion boards
- Easy access openings for PC/104 expansion board connectors or cabling
- Accepts any capacity 2 ½" Hard Disk Drive
- Mechanical
 - ◆ Flexible mounting – Wall or Benchtop (Surface)
 - ◆ All cabling provided internally
- Certification
 - ◆ Designed for EMI Standards
 - ◆ Designed for UL/CSA/CE Approval (depends on the exact system assembled)
- Power
 - ◆ Momentary Power On/Off switch
 - ◆ 150W ATX power supply built in
 - ◆ 110/220V +/-10%, @ 50/60 Hz, Auto-sense input

I/O Panel Description

Table B-1 describes the connectors or controls on the I/O panel provided with the ReadyBox ATX, and shown in Figure B-3.

Table B-1. Installed Connectors or Controls

Control/Connector	Description
Power Switch	This momentary push button Power switch controls AC power and is provided with the ReadyBox along with its internal cable. The integrator must connect it to the ReadyBoard through a 2-wire, 5-pin connector at the Utility connector.
AC Power In	This 3-prong connector is part of the internal ATX power supply and accepts 100-240 VAC, +/- 10% @ 50/60 Hz
Power Supply Fan	This fan is part of the internal ATX power supply and provides cooling to the power supply.
Parallel	This 25-pin connector and its internal cable are provided with the ReadyBox. The integrator must connect it to the ReadyBoard Floppy/Parallel connector.
MIC, Line In, Line Out	These three 2-pin connectors and the respective cable are provided with the ReadyBox. The integrator must connect these to the Audio In/Out connector on the ReadyBoard.
COM 3 & COM 4 (Serial 3 & Serial 4)	These two 9-pin connectors and the respective cables are provided with the ReadyBox. The integrator must connect these to the ReadyBoard Serial B connector.
USB 2 & 3	These two 4-pin connectors and the respective cables are provided with the ReadyBox. The integrator must connect these to the ReadyBoard USB header.
Hard Disk Drive (2 1/2") Tray	This HDD tray assembly, provided with the ReadyBox, will hold a 2 1/2" hard disk drive with a 44-pin connector along with its shock mounting.
Compact Flash cover and slot	This compact flash cover and slot (not shown) provided with the ReadyBox, ensures good EMI shielding and protects the compact flash card if installed.

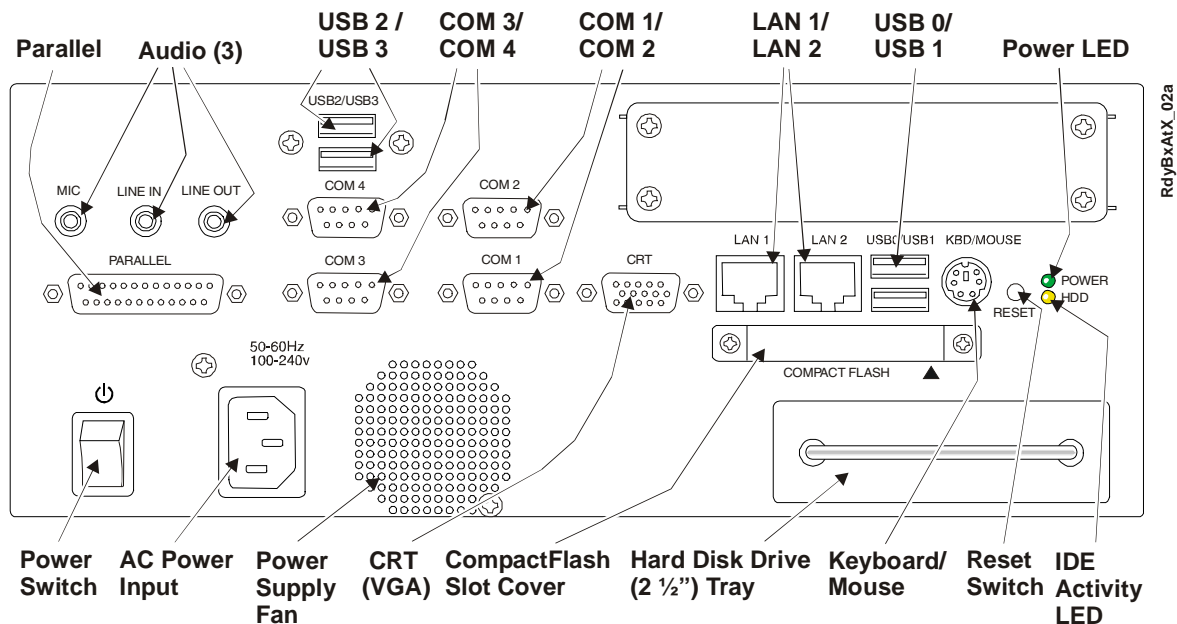

Figure B-3. I/O Panel Controls and Connectors

Table B-2 describes the connector, control, or indicator openings in the I/O panel provided with the ReadyBoard SBC, and shown in Figure B-3.

Table B-2. Connectors or Control/Indicator I/O Panel Openings

Access Opening	Description
Power-On LED	This power-on indicator is provided on the ReadyBoard.
HDD Activity LED	This IDE activity indicator shows when there is I/O activity for the IDE hard drive or compact flash card and is provided on the ReadyBoard.
Reset Switch	This reset switch is provided on the ReadyBoard. Pressing the Reset switch supplies a ground signal on the reset line causing a hard reset.
Keyboard/Mouse	This 6-pin single PS/2 Keyboard/Mouse connector is provided on the ReadyBoard. It requires a dual PS/2 output cable provided in the ReadyBoard SBC QuickStart kit.
USB 0 & 1	These two 4-pin USB type A connectors are provided on the ReadyBoard.
LAN 1 (Ethernet 1)	This 8-pin RJ45 connector is provided on the ReadyBoard.
LAN 2 (Ethernet 2)	This 8-pin or 10-pin RJ45 connector is provided on the ReadyBoard.
Video (CRT VGA)	This 15-pin DB15 connector is provided on the ReadyBoard.
COM 1 & COM 2 (Serial 1 & Serial 2)	These two 9-pin DB9 connectors are provided on the ReadyBoard.
compact flash socket	The compact flash socket (not shown) is provided on the underside of the ReadyBoard and accepts the compact flash card through the opening in the I/O panel of the ReadyBox ATX, if installed.

Power/IDE LED Definitions

Table B-3 provides the LED colors and definitions for the Power On and IDE drive activity LEDs. See Figure B-3. Refer to the specific ReadyBoard SBC for the Ethernet LED activity.

Table B-3. Power/IDE Activity LED Indicators

LED#	On	Off
Power On LED	Steady Green = Power On	Steady Off = Power Off
IDE Activity LED	Flashing Yellow = IDE activity (2 ½" IDE drive or compact flash)	Steady Off = No IDE activity

Specifications

Environmental Specifications

Table B-4 provides the most efficient operating and storage condition ranges required for the ReadyBoard SBC installed into the ReadyBox ATX.

Table B-4. Environmental Requirements

Parameter	Conditions
Temperature	
Operating	+0°to+50°C (32°to+122°F)
Storage	-20°to+75°C (-4°to+167°F)
Humidity	
Operating	5% to 95% relative humidity, non-condensing
Non-operating	5% to 95% relative humidity, non-condensing

Power Specifications

Table B-5 list the power specifications of the ATX power supply installed in the ReadyBox ATX.

Table B-5. Power Supply Specifications

Parameter	Description
Input Type	Auto ranging, 100-240 VAC, +/-10%, @ 50/60 Hz
Output Type	Regulated DC voltages
	+3.3 VDC +/-5% @ 10 A Max (Not used by the ReadyBoard)
	+5 VDC +/-5% @ 14 A Max
	+12 VDC +/-5% @ 4.2 A Max (Required for the Enclosure fan, and used as an option on some ReadyBoards)
	-12 VDC +/-10% @ 0.3 A Max (Not used by the ReadyBoard)
	+5 VDC Standby +/-5% @ 2A Max
Output Power MAX	150W (Output of +3.3V and +5V not to exceed 85W)

Enclosure Cooling Requirements

The ReadyBox ATX enclosure only requires additional cooling when specific ReadyBoard SBCs are installed into the enclosure. Only the ReadyBoard SBCs listed in Table B-6 require installation of an optional system fan in the enclosure.

Table B-6. Optional System Fan Required

Model	CPU Types Requiring Enclosure System Fan	
ReadyBoard 700	Intel Celeron, 650 MHz LV	Intel Pentium III, 933 MHz LV
ReadyBoard 710	Intel Celeron, 650 MHz LV	
ReadyBoard 800	Intel Celeron M, 1.0 GHz ULV	Intel Pentium M, 1.4 GHz LV

Physical Specifications

Table B-7 gives the physical dimensions of the ReadyBox ATX as shown in Figures B-4 and B-5, and the mounting dimensions in Figures B-6 and B-7.

Table B-7. Weight and Footprint Dimensions

Parameters	Measurements (Enclosure Only)	Additional Measurements
Weight	2.95 kg (6.5 lb)	
Height	115 mm (4.52")	123 mm (4.84") with plastic feet
Width	280 mm (11.02")	319.8 mm (12.59") with mounting brackets
Depth	180 mm (7.08")	195.50 mm (7.69") HDD Tray handle

Mechanical Specifications

Figures B-4 through B-7 show the ReadyBox ATX dimensions, mounting and access plate locations, cover locations, and the mounting dimensions.

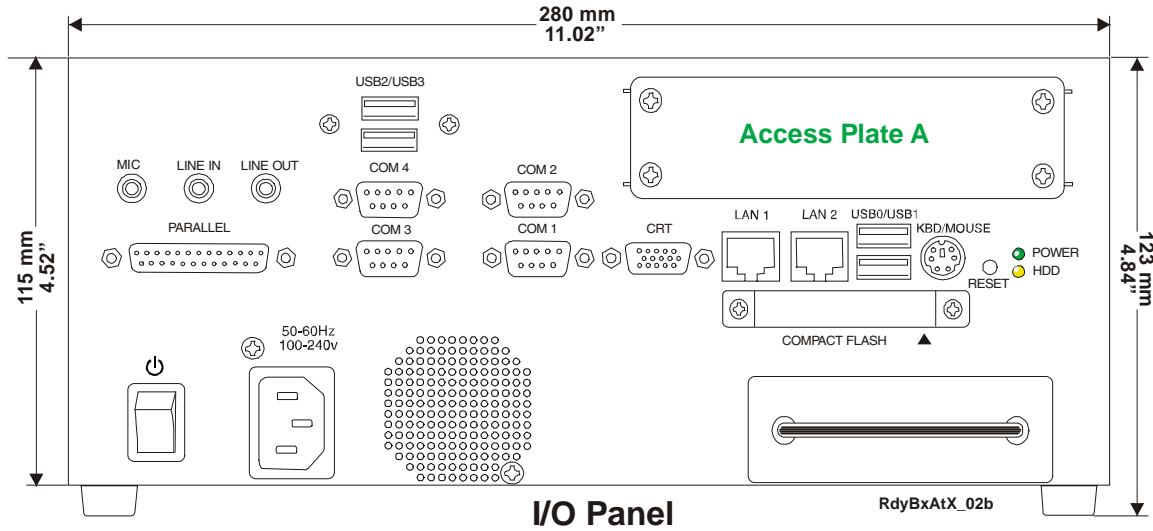

Figure B-4. Width and Height Dimensions (Front view)

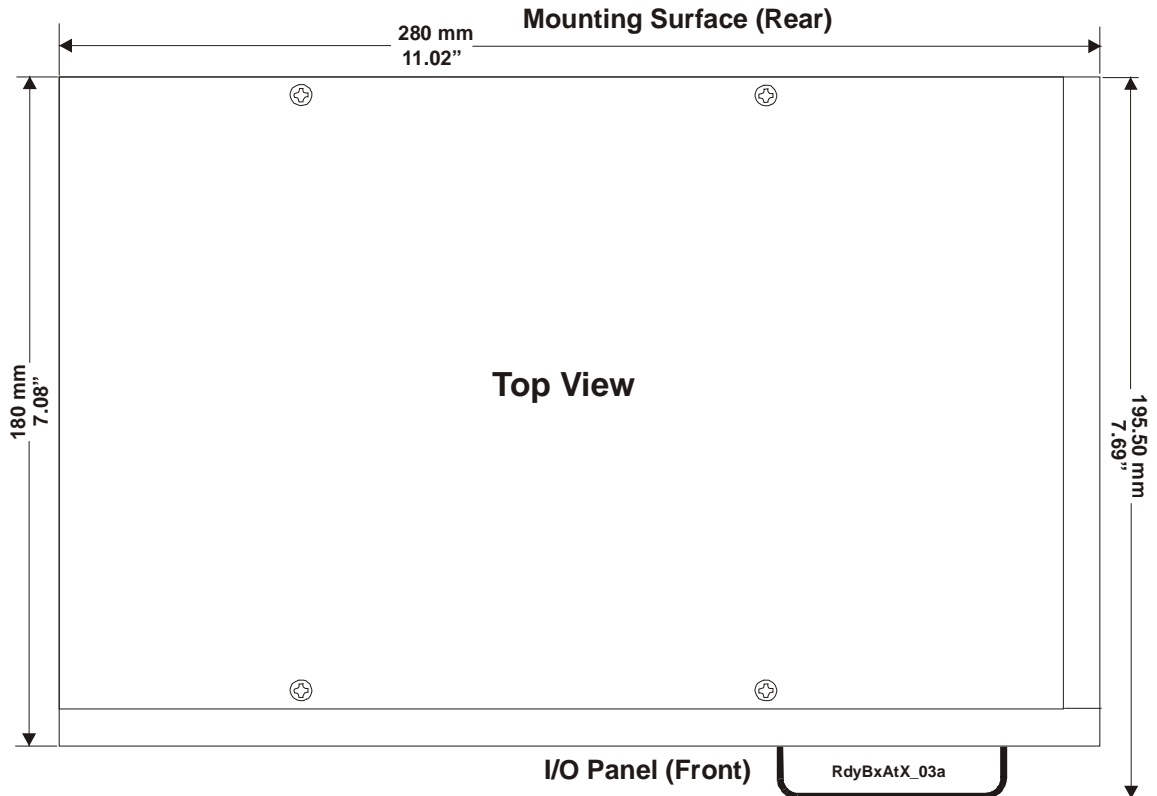
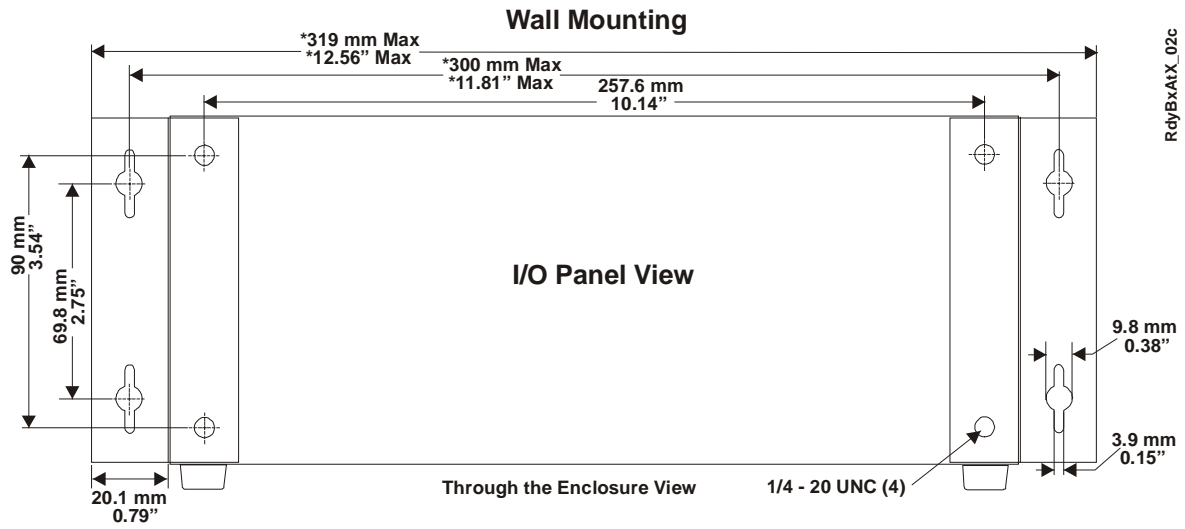
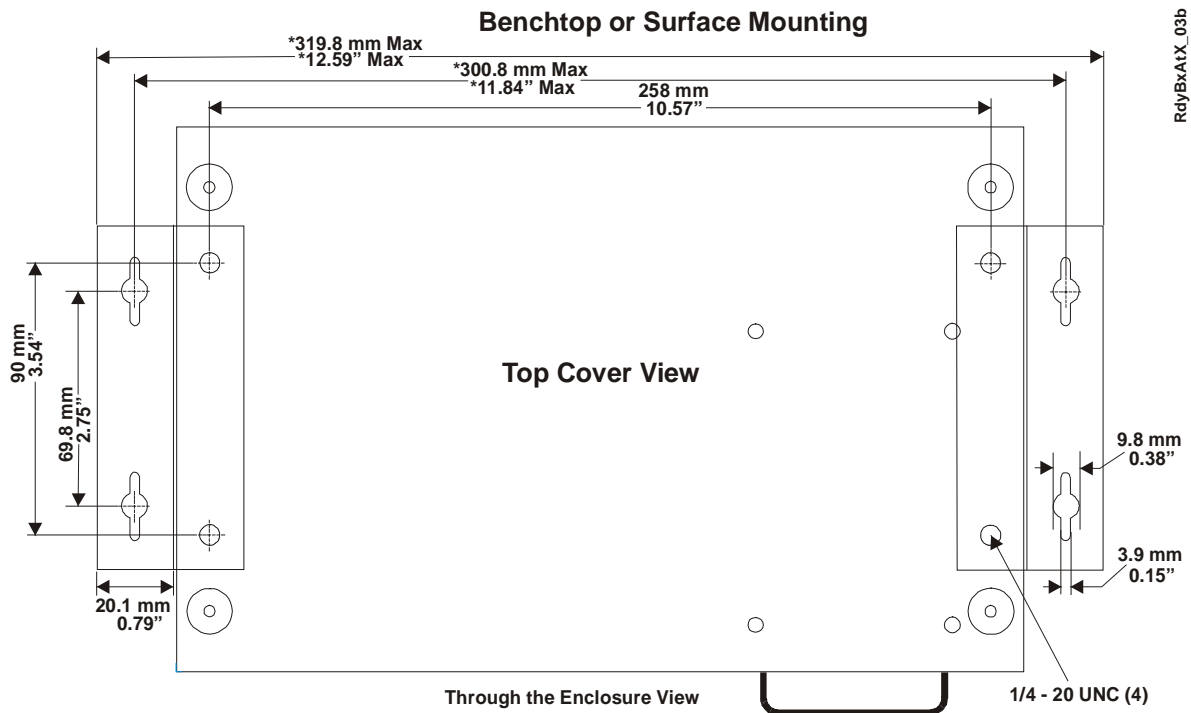

Figure B-5. Width and Depth Dimensions (Top view)



*Note: Can subtract up to 1.75 mm (0.068") from both ends due to hole size in mounting bracket placement.

Figure B-6. Wall Mounting Dimensions (I/O Panel view)



*Note: Can subtract up to 1.75 mm (0.068") from both ends due to hole size in mounting bracket placement.

Figure B-7. Surface or Benchtop Mounting Dimensions (Top view)

Mounting Locations, Access Plates, and Covers

Figures B-8 and B-9 provide the mounting plate, access plate, and cover locations. The four optional plastic feet with screws are also shown in Figure B-8.

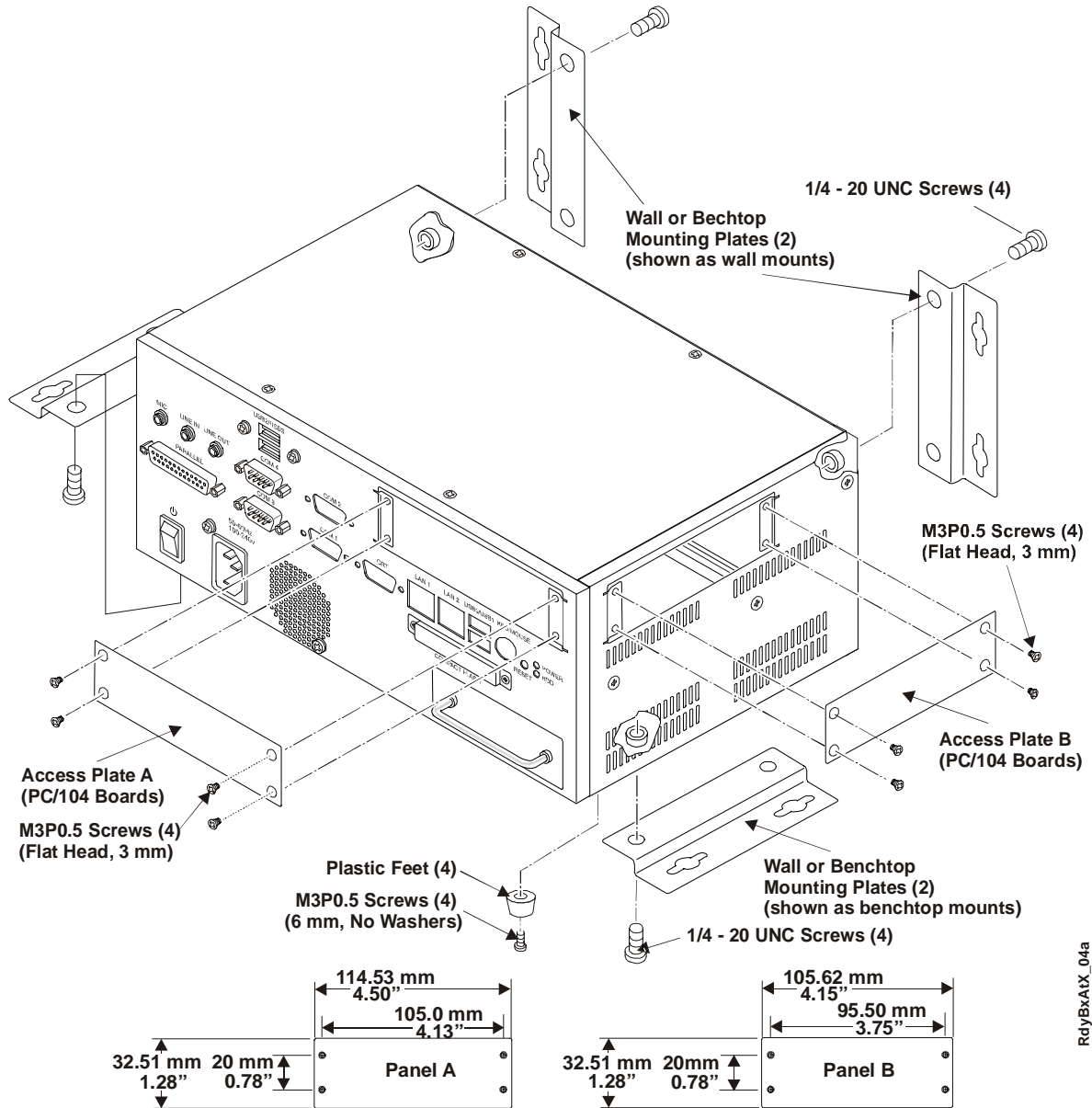

RdyBxAtX_04a

Figure B-8. Mounting and PC/104 I/O Access Plate Locations

NOTE The two access plates (A & B), shown in Figure B-8 (used for PC/104 input/output connections) are not the same width. See also Table B-8.

Table B-8. Access Plate Dimensions

	Access Plate A	Access Plate B
Width	114.53 mm (4.509")	105.62 mm (4.158")
Height	32.51 mm (1.28")	32.51 mm (1.28")

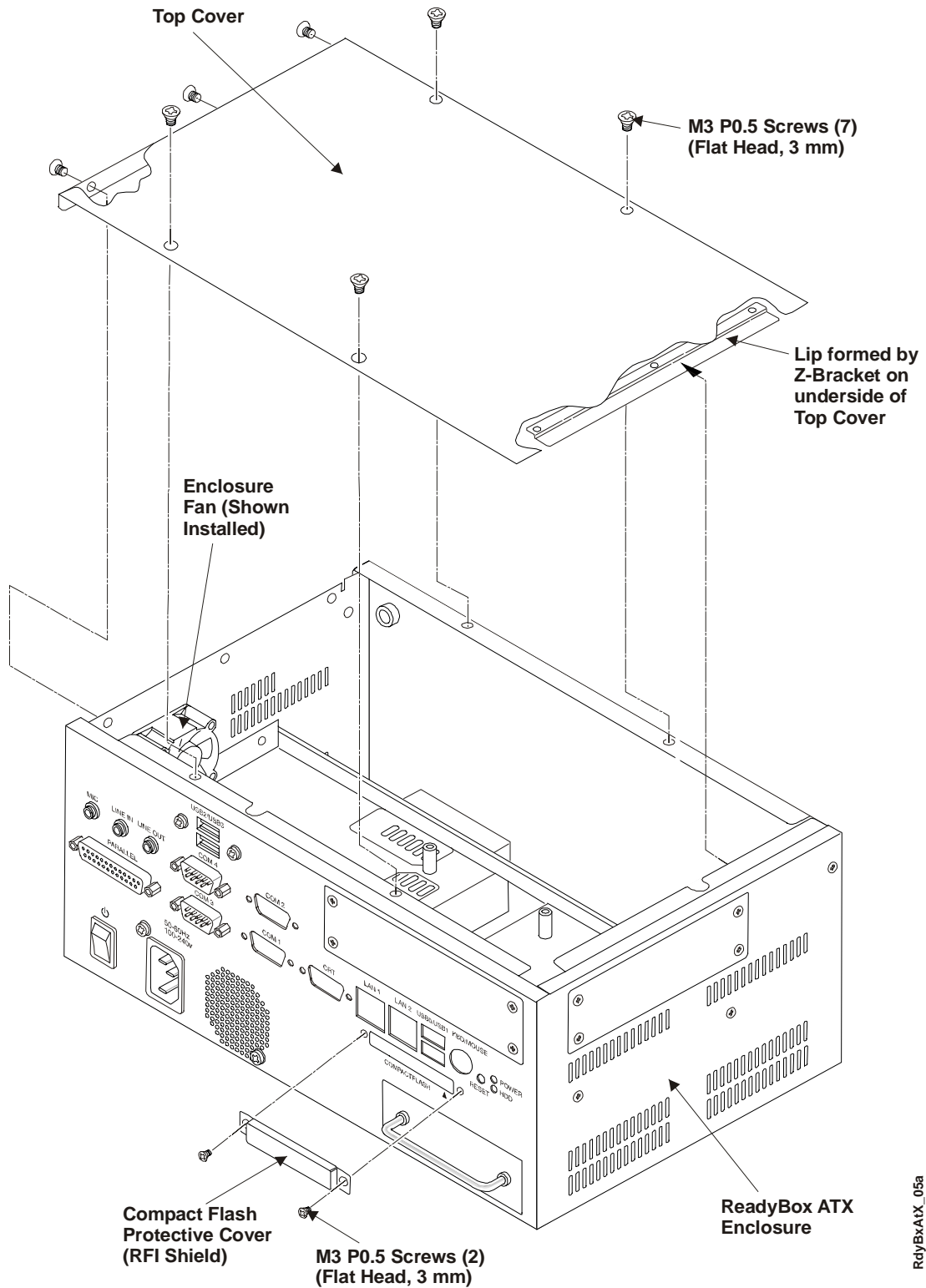

RdyBxAtx_05a

Figure B-9. Enclosure Cover Locations

CAUTION To prevent damage to the top cover after removing the seven screws, you must slide the top cover to the left before lifting the top cover off the enclosure, due to the Z-bracket lip.

