



ReadyBoard™ 800 Single Board Computer QuickStart Guide

P/N 5001805A Revision A

Notice Page

NOTICE

No part of this document may be reproduced, transmitted, transcribed, stored in a retrieval system, or translated into any language or computer language, in any form or by any means, electronic, mechanical, magnetic, optical, chemical, manual, or otherwise, without the prior written permission of Ampro Computers, Incorporated.

DISCLAIMER

Ampro Computers, Incorporated makes no representations or warranties with respect to the contents of this manual or of the associated Ampro products, and specifically disclaims any implied warranties of merchantability or fitness for any particular purpose. Ampro shall under no circumstances be liable for incidental or consequential damages or related expenses resulting from the use of this product, even if it has been notified of the possibility of such damages. Ampro reserves the right to revise this publication from time to time without obligation to notify any person of such revisions. If errors are found, please contact Ampro at the address listed below on the Notice page of this document.

TRADEMARKS

Ampro and the Ampro logo are registered trademarks, and CoreModule, EnCore, Little Board, LittleBoard, MiniModule, ReadyBoard, ReadyBox, ReadyPanel, and ReadySystem are trademarks of Ampro Computers, Inc. All other marks are the property of their respective companies.

REVISION HISTORY

Revision	Reason for Change	Date
A, A	Initial Release	Jul/06

Ampro Computers, Incorporated
5215 Hellyer Avenue
San Jose, CA 95138-1007
Tel. 408 360-0200
Fax 408 360-0222
www.ampro.com

© Copyright 2006 Ampro Computers, Incorporated

Audience Assumptions

This guide is for the person who designs computer related equipment, including but not limited to hardware and software design and implementation of the same. Ampro Computers, Inc. assumes you are qualified in designing and implementing your hardware designs and its related software into your prototype computer equipment.

Contents

Chapter 1	Setting Up the ReadyBoard 800	1
Using this Guide		1
Requirements		1
What's in the Box		1
Setup Steps		2
Preparations		2
Setting Up the Workspace		2
Connecting Cable Assemblies		3
Connecting Peripherals		8
Connecting Boot Devices		8
Connecting Monitor and Power Supply		9
Applying Power to the ReadyBoard 800		9
Chapter 2	Installing ReadyBoard 800 Options	13
Memory Installation		13
Tools Required		13
Installation Guidelines		13
Removing the SODIMM		13
Installing the SODIMM		15
Compact Flash Installation		17
Tools Required		17
Installation Guidelines		17
Installing the Compact Flash Card		17
Removing the Compact Flash Card		20
Installing MiniModule ISA		22
Tools Required		22
Installation Guidelines		22
Installing the MiniModule ISA Board		22
Removing the MiniModule ISA Board		24
Installing Software, Drivers, and Utilities		25
Appendix A	Technical Support	27

NOTE

The graphic illustrations found in this manual are intended as aids in identifying the connector locations and components on the board. You may find slight variations between your board and the boards shown in this manual to due board revisions. Refer to Figure 1-4 and the ReadyBoard 800 Reference Manual for the most current board revision and the connector pin/signal tables for specific information.

List of Figures

Figure 1-1. ReadyBoard 800 Connector Locations	3
Figure 1-2. Connecting the Floppy Only Cable to ReadyBoard 800	4
Figure 1-3. Connecting IDE, Keyboard/Mouse, Parallel, and Serial Cable Assemblies	4
Figure 1-4. ReadyBoard 800 Connector and Pin-Locations	5
Figure 1-5. Connecting Audio In/Out and ATX Power Adapter Cable Assemblies	6
Figure 1-6. Connecting the Utility and USB Cable Assemblies	7
Figure 2-1. ReadyBoard 800 SODIMM Location (Bottom view)	14

Contents

Figure 2-2. Removing SODIMM from Socket	15
Figure 2-3. Installing SODIMM into Socket	16
Figure 2-4. Installing the Compact Flash Card	19
Figure 2-5. Compact Flash Card Installed.....	20
Figure 2-6. Removing the Compact Flash Card	21
Figure 2-7. Installing the MiniModule ISA Expansion Board	23
Figure 2-8. Removing the MiniModule ISA Board	24

List of Tables

Table 1-1. Jumper Settings.....	12
Table 1-2. ATX Power Adapter Cable to ReadyBoard Wiring	12
Table 2-1. Compact Flash Jumper Setting	19
Table A-1. Technical Support Contact Information.....	27

Chapter 1 Setting Up the ReadyBoard 800

Using this Guide

This guide provides the most efficient way to set up your ReadyBoard™ 800 single board computer (SBC). The instructions provided in this guide include:

- Removing the ReadyBoard 800 from the shipping container and inventorying the accessories
- Connecting cables to the ReadyBoard 800
- Connecting the peripherals, boot devices, and power supply to the ReadyBoard 800
- Powering up the ReadyBoard 800

Information not provided in this QuickStart Guide includes:

- ReadyBoard 800 Specifications (Refer to ReadyBoard 800 Reference Manual)
- Environmental requirements (Refer to ReadyBoard 800 Reference Manual)
- ReadyBoard 800 connector/pin numbers and definitions (ReadyBoard 800 Reference Manual)
- Supplied software use and programming considerations (ReadyBoard 800 Reference Manual)

Requirements

The following peripherals and devices are needed to make full use of the ReadyBoard 800.

- Peripherals: (Customer Provided)
 - ◆ PS/2 or USB Keyboard
 - ◆ PS/2 or USB Mouse
 - ◆ CRT Monitor
- Power Supply: (Customer Provided)
 - ◆ ATX or Lab power supply – This type of power supply is required to provide power to the ReadyBoard 800 and its peripheral devices.
- Choice of Boot Device: (Customer Provided)
 - ◆ Floppy Disk drive
 - ◆ IDE hard disk drive (See preinstalled OS Note in text)
 - ◆ Compact flash card (See preinstalled OS Note in text)
 - ◆ CD-ROM
- Optional Devices/Connections: (Customer Provided)
 - ◆ TFT Flat Panel
 - ◆ Ethernet (or LAN Boot - Refer to ReadyBoard 800 Reference Manual)
 - ◆ USB devices
 - ◆ Audio components, such as stereo amplifiers, receivers, CD Players, and microphones

What's in the Box

Refer to the QuickStart Kit Contents Sheet for a list of the cables, documents, and other items in the shipping container.

Setup Steps

It is important to follow the setup steps in this section in the exact order listed here, but skip any steps that do not apply to your situation. References are provided to chapters within this guide or other Ampro guides, for more information about installation and use of this ReadyBoard 800.

Preparations

1) Open shipping box	<ul style="list-style-type: none"> • Locate the QuickStart Kit Contents Sheet • Unpack the contents of the shipping box
2) Verify Contents	<ul style="list-style-type: none"> • Verify the contents of the shipping box against the QuickStart Contents Sheet included with your ReadyBoard 800 shipping box. • If anything is missing or damaged, call your sales representative.
3) Support Documentation (ReadyBoard 800 Documentation & Support Software CD-ROM)	<p><i>ReadyBoard 800 QuickStart Guide</i></p> <p>This document describes how to setup, install, and power up the ReadyBoard 800 found in the QuickStart Kit and is located on the ReadyBoard 800 Documentation & Software (Doc & SW) CD-ROM as a PDF file.</p>
	<p><i>ReadyBoard 800 Reference Manual</i></p> <p>This document describes the ReadyBoard 800 and provides detailed reference information for your ReadyBoard 800 and is located on the ReadyBoard 800 Documentation & Software (Doc & SW) CD-ROM as a PDF file.</p>

Setting Up the Workspace

CAUTION	<p>To prevent damage to the electronic components on the ReadyBoard 800, do not handle the board until you have used Electrostatic Discharge precautions.</p> <p>Always use an anti-static wrist strap connected to a grounding mat having static-dissipating characteristics and is attached to earth ground.</p> <p>Always touch a grounded, unpainted metal surface before touching the ReadyBoard 800 or any of the components on the board.</p>
----------------	--

4) Select workbench location	<ul style="list-style-type: none"> • The workbench location should be flat, clear of debris, and have a static-free mat (or the equivalent) to place the ReadyBoard 800 assembly onto for setup and operation (including the power supply and any peripherals).
5) Connect an ESD strap to your body	<ul style="list-style-type: none"> • Connect an ESD strap between your body (wrist or ankle) and ground or the static-free mat. <p>If you do not have your own ESD strap, an ESD kit is provided in the QuickStart Kit with an anti-static wrist strap.</p>
6) Unpack the ReadyBoard 800 and its accessories.	<ul style="list-style-type: none"> • Remove the ReadyBoard 800 from its protective plastic case and place it on static-free work surface, typically on four standoffs. <p>The cables provided are used to make external connections to the ReadyBoard 800 such as keyboard, mouse, floppy drive, IDE drives, and power, etc.</p> <p>* Ampro recommends using standoffs and screws (8) to support the ReadyBoard 800 while it is operational. See Figure 1-1.</p>

Connecting Cable Assemblies

Connect the cables provided with the ReadyBoard 800 QuickStart Kit to the respective connectors on the ReadyBoard 800. Skip any steps or cable(s) that do not apply to your situation.

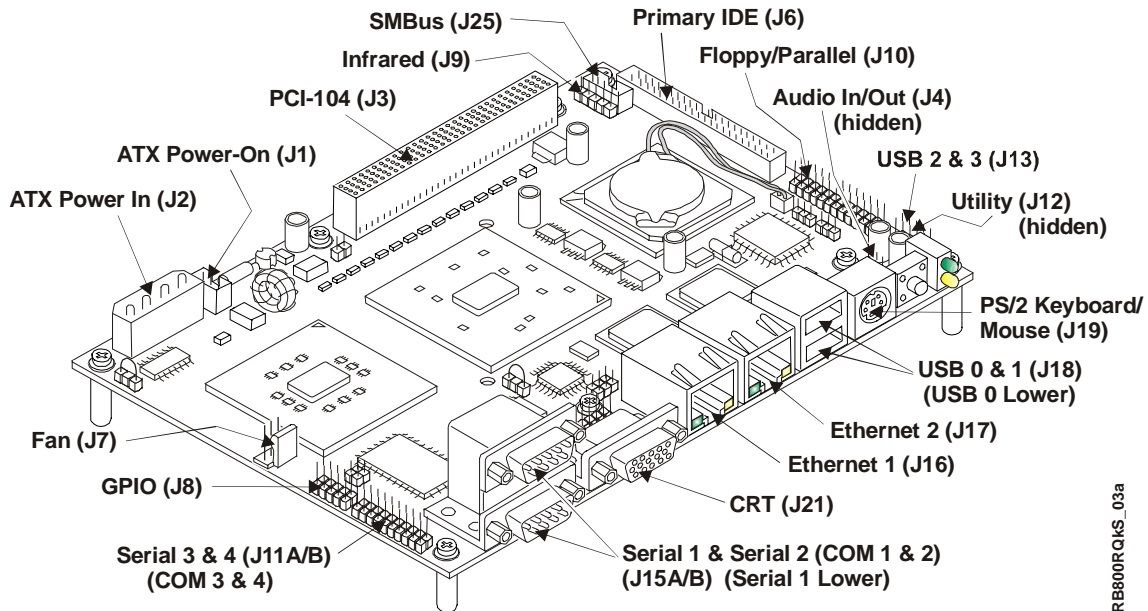

RB800RQMS_03a

Figure 1-1. ReadyBoard 800 Connector Locations

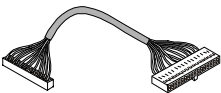
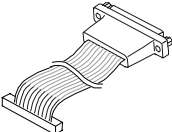
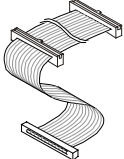
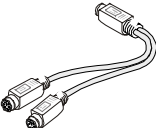
<p>1) Connect the Floppy only Cable</p> 	<ul style="list-style-type: none"> Connect the Floppy only cable to J10 on the edge of the ReadyBoard 800 as shown in Figure 1-2. Refer also to Figures 1-1, 1-4. <p>The Floppy interface and Parallel Port share interface connector J10. You must choose which cable to connect to the J10, depending on the desired function; floppy only cable, or printer only cable.</p>
<p>2) If you want Printer only perform this step</p> 	<ul style="list-style-type: none"> If you only want a Printer (parallel) and don't need a floppy drive, then remove the Floppy only cable and connect the Parallel (printer) only cable to J10 on the edge of the ReadyBoard 800 as shown in Figure 1-3. Refer also to Figures 1-1, 1-4.
<p>3) Connect the Primary IDE cable</p> 	<ul style="list-style-type: none"> Connect the Primary IDE cable to J6 on the edge of the ReadyBoard 800 as shown in Figure 1-3. Refer also to Figures 1-1, 1-4. <p>This cable provides two IDE connectors (40-pin) for an IDE device, such as an IDE hard disk drive (HDD) or IDE CD-ROM, etc.</p> <p>NOTE A 44-pin-to-40-pin cable is provided for a 3 1/2" IDE device, and a 44-pin-to-44-pin cable is provided for a 2 1/2" IDE HDD.</p>
<p>4) Connect the Keyboard/Mouse Y-cable</p> 	<ul style="list-style-type: none"> Connect the Keyboard/Mouse Y-cable assembly to the Keyboard/Mouse port (J19) on the edge of the ReadyBoard 800 as shown in Figure 1-3. Refer also to Figures 1-1, 1-4. <p>This cable assembly provides two connectors for the PS/2 Keyboard-PS/2 Mouse shared port and each PS/2 connector has an icon for the respective PS/2 device.</p>

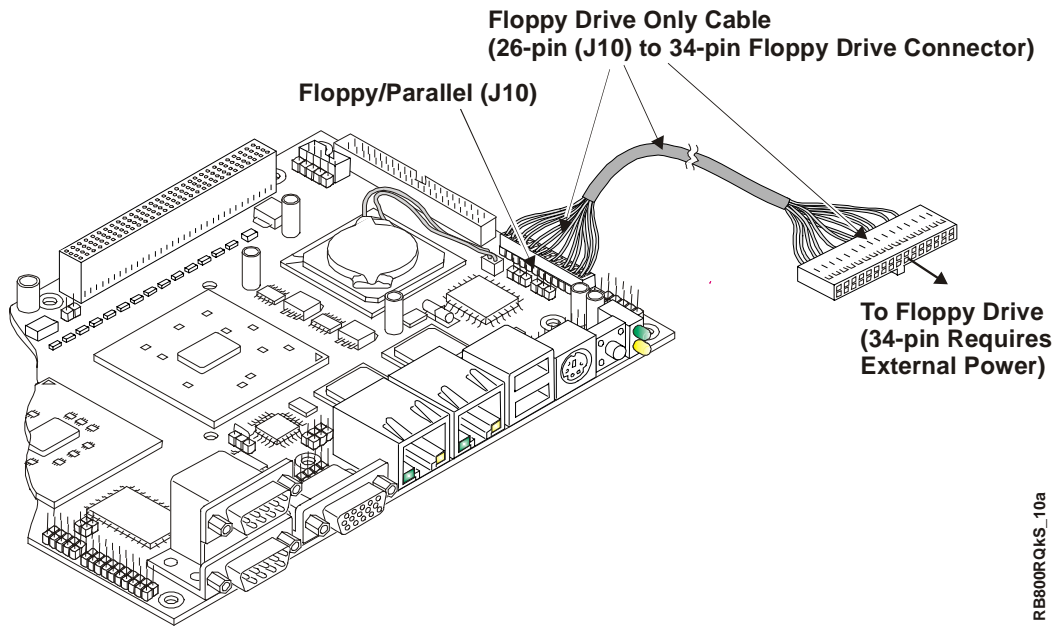

Figure 1-2. Connecting the Floppy Only Cable to ReadyBoard 800

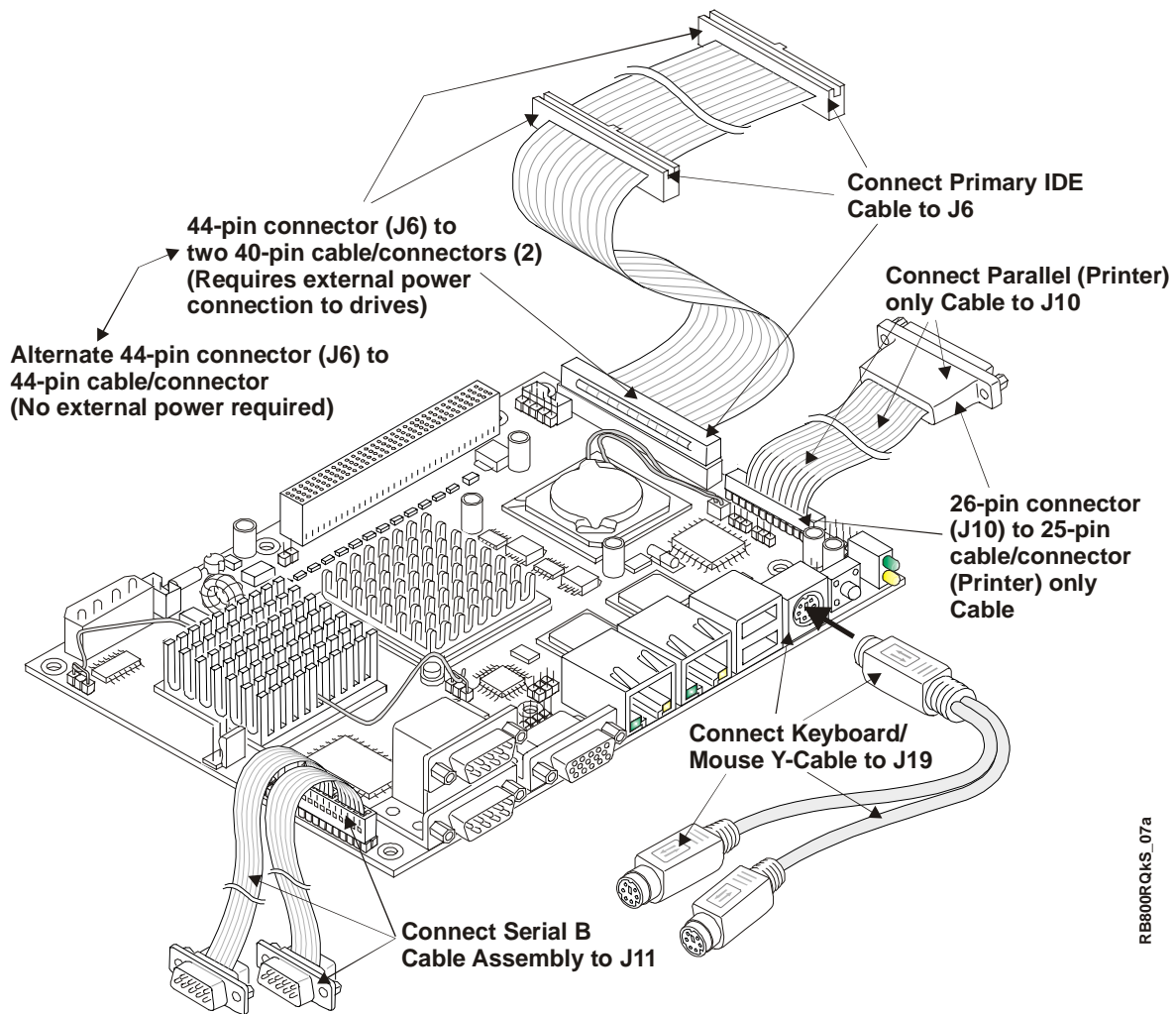
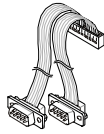

Figure 1-3. Connecting IDE, Keyboard/Mouse, Parallel, and Serial Cable Assemblies

5) Connect the Serial B Cable assembly



- Connect the Serial B (COM3 & 4) cable assembly to J11 on the edge of the ReadyBoard 800 as shown in Figure 1-3. Refer also to Figures 1-1, 1-4.

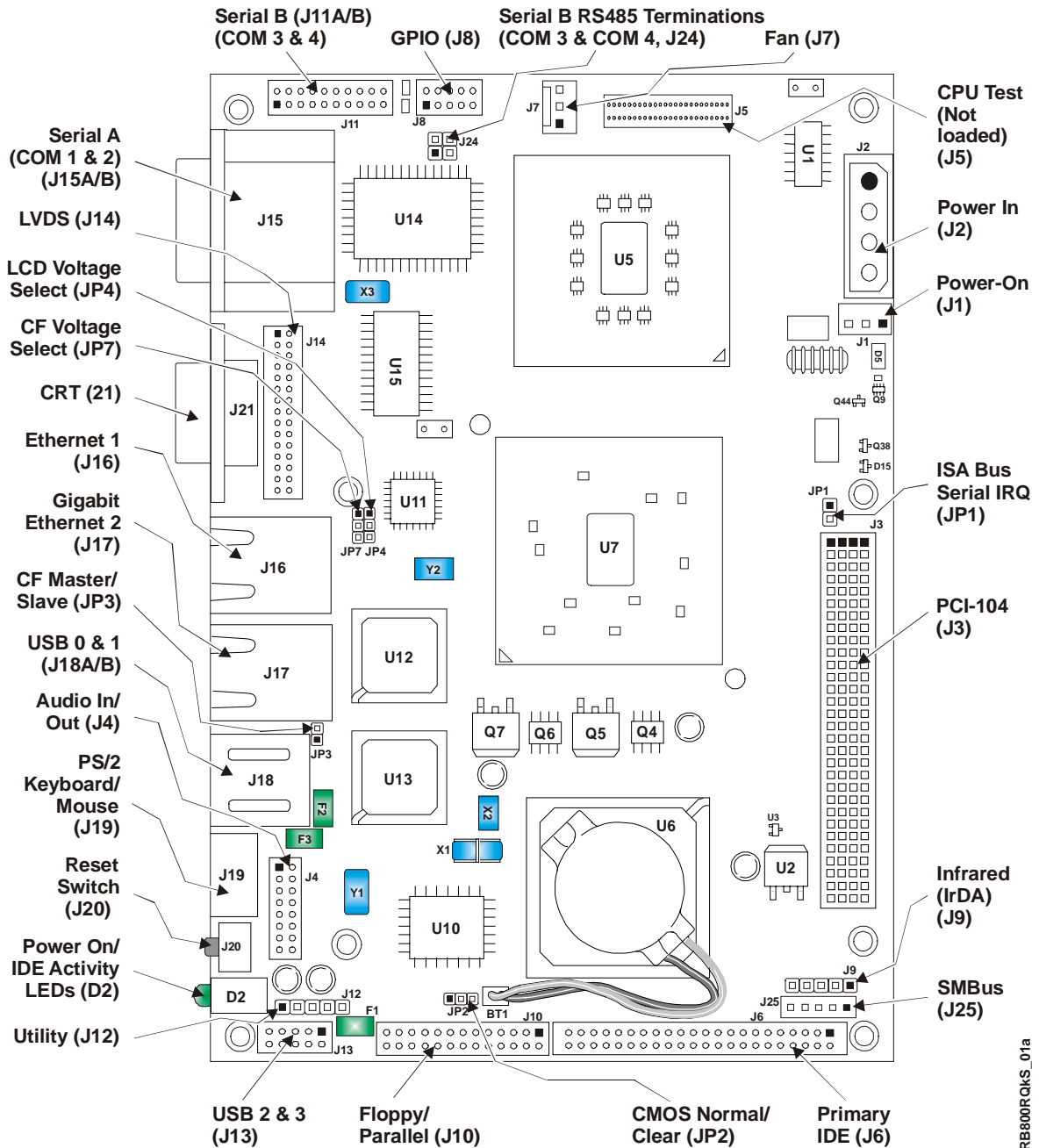
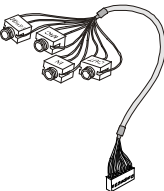
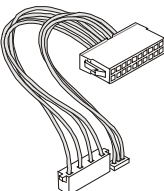

Figure 1-4. ReadyBoard 800 Connector and Pin-Locations

NOTE

Ensure you match the red strip on the ribbon cables (pin 1) to the pin 1's on the connectors as shown in Figure 1-4. To comply with the PC/104, PC/104-Plus, or PCI-104 specifications, some pins in the connectors/headers are missing or have keys blocking the pins.

Skip any of the following steps that do not apply to your situation.	
<p>6) Connect the Audio In/Out Cable Assembly</p> 	<ul style="list-style-type: none"> Connect the Audio In/Out cable assembly to J4 near the edge of the ReadyBoard 800 as shown in Figure 1-5. <p>Refer also to Figures 1-1, 1-4.</p> <div style="border: 1px solid black; padding: 5px;"> <p>NOTE The headphone connector in the cable assembly is not connected at the J4 connector on the ReadyBoard 800.</p> </div>
<p>7) Connect the ATX Power Adapter Cable Assembly</p> 	<ul style="list-style-type: none"> Connect the ATX power adapter cable assembly to J1 and J2 on the edge of the ReadyBoard 800 as shown in Figure 1-5. <p>Refer also to Figures 1-1, 1-4.</p> <p>The ATX power adapter was separated for non-ATX power supplies and provides a separate power on/standby connector (J1) from the power input voltage (J2).</p> <p>* If you do not use an ATX power supply, you will have to provide the standby voltage (+5V) to J1 for the soft off function.</p>

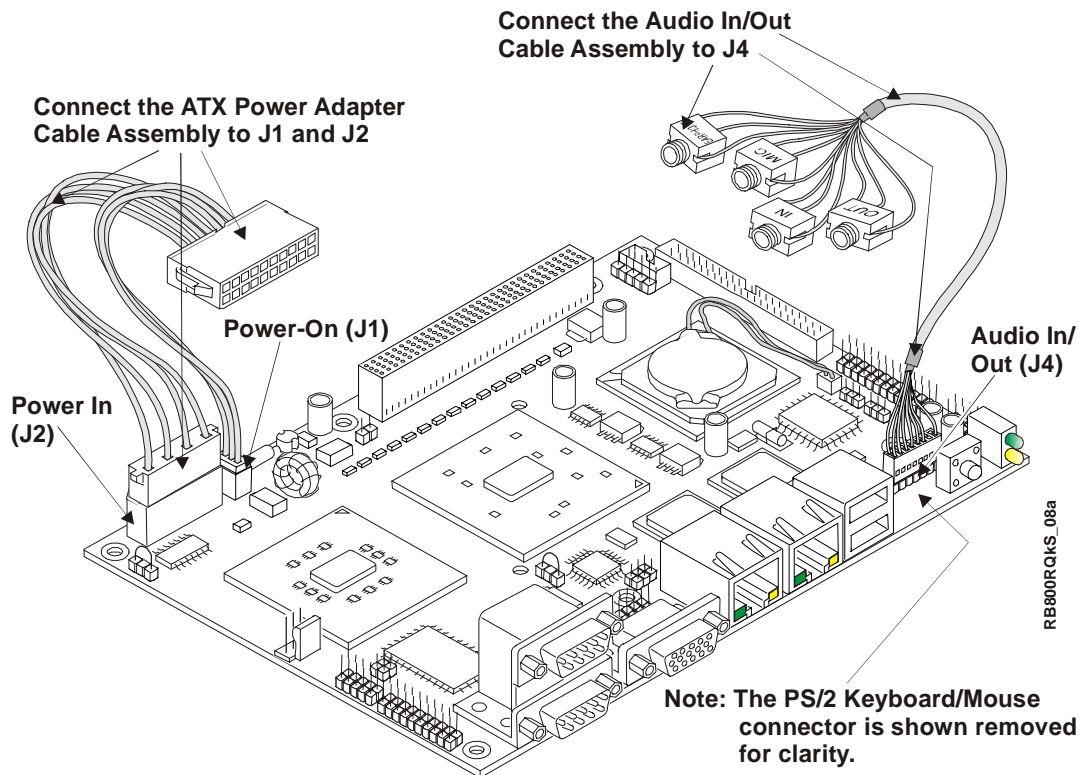
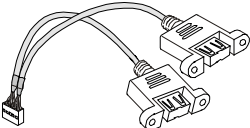
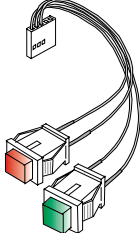

Figure 1-5. Connecting Audio In/Out and ATX Power Adapter Cable Assemblies

NOTE

The ReadyBoard 800 requires +5V on pin-1 of J1 to operate properly. Failure to connect both ATX power supply connections or supply +5V to pin-1 of J1 will prevent your ReadyBoard 800 from powering on. Refer to Table 1-2 for more information.

<p>8) Connect USB 2 & 3 Cable Assembly</p> 	<ul style="list-style-type: none"> • Connect the USB 2 & 3 cable assembly to J13 on the edge of the ReadyBoard 800 as shown in Figure 1-6. <p>Refer also to Figures 1-1, 1-4.</p>
<p>9) Connect Utility Cable Assembly</p> 	<ul style="list-style-type: none"> • Connect the Utility cable assembly to J12 near the edge of the ReadyBoard 800 as shown in Figure 1-6. <p>Refer also to Figures 1-1 and 1-4.</p> <ul style="list-style-type: none"> ◆ The <u>green</u> Power-On switch uses Pins-1 & -2 of the Utility Connector. ◆ The <u>red</u> Reset switch uses Pins-2 and -3 of the Utility Connector.

NOTE

The Power-On switch turns the ReadyBoard 800 to an On condition, if you are using an ATX power supply. Normally, the operating system (OS) will turn Off the ReadyBoard during the OS shutdown process. However, if you need to turn off the ReadyBoard, pressing and holding the Power-On button for more than 4-6 seconds will turn the ReadyBoard 800 to an Off state.

For information concerning power management and “sleep states” under the ACPI standard, refer to the topic *Power and Sleep States* in the *ReadyBoard 800 Reference Manual*.

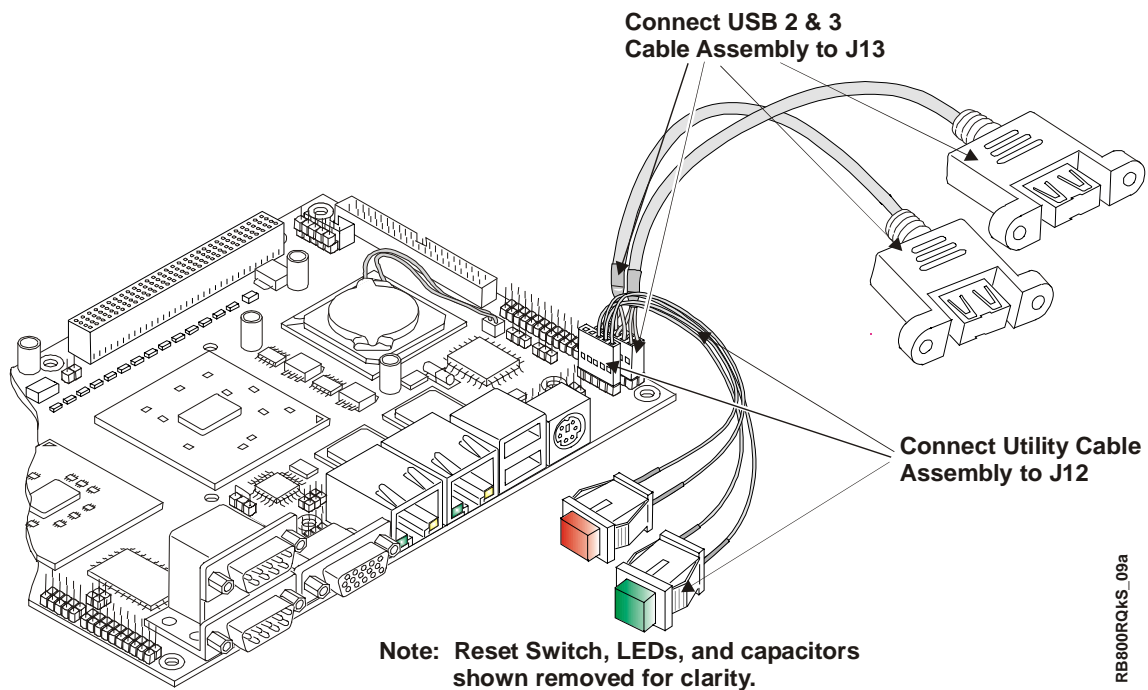

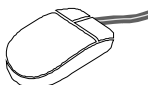

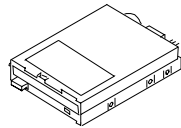
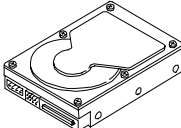
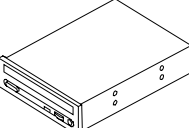
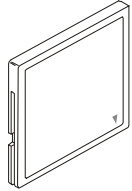

Figure 1-6. Connecting the Utility and USB Cable Assemblies

RB800RQKS_09a

Connecting Peripherals

<p>10) Connecting I/O peripherals</p> 	<ul style="list-style-type: none"> • Connect the Keyboard to the PS/2 connector with the keyboard icon on the Y-cable attached to J19. • If your are using a USB keyboard, connect it to the USB 0 connector (lower USB on J18) on the edge of the ReadyBoard 800.
	<ul style="list-style-type: none"> • Connect the mouse cable to the PS/2 connector with the mouse icon on the Y-cable attached to J19. • If your are using a USB mouse, connect it to the USB 1 connector (upper USB on J18) on the edge of the ReadyBoard 800.

Connecting Boot Devices

<p>11) Connect the OS boot device(s)</p> 	<ul style="list-style-type: none"> • Use one of the seven options listed here to connect an (OS) boot device(s) to the ReadyBoard 800: <ol style="list-style-type: none"> Connect a floppy disk drive(FDD) to the floppy drive only cable connected to J10 on the edge of the ReadyBoard 800. <p>Or Connect a USB floppy drive to one of the USB ports, Or</p>
	<ol style="list-style-type: none"> Connect an IDE hard disk drive (HDD) to a free connector on the primary IDE cable (J6) on the edge of the ReadyBoard 800. <p>Or, Connect a USB hard disk drive to one of the USB ports, Or</p> <p>* Ampro does not recommend using a preinstalled OS on a HDD to boot and load the operating system. See Note with Step 17.</p>
	<ol style="list-style-type: none"> Connect a CD-ROM drive to an available connector on the primary IDE cable (J6) on the edge of the ReadyBoard 800. <p>Or Connect a USB CD-ROM to one of the USB ports, Or</p>
 <p>Compact Flash (CF) Card</p>	<ol style="list-style-type: none"> Install a compact flash (CF) card with a bootable OS into the compact flash socket (J23) located on the underside of the board. <p>Instructions and limitations for installing the compact flash card into the socket (J23) on the ReadyBoard 800 are provided in Chapter 2, <i>Installing ReadyBoard 800 Options</i> later in this manual.</p> <p>* Ampro does not recommend using a preinstalled OS on a CF card to boot and load the operating system. See Note with Step 17.</p>
 <p>Ethernet Connection</p>	<ol style="list-style-type: none"> Connect an Ethernet cable to Ethernet 1 (J16, LAN 1) for the LAN Boot feature. Refer to the LAN Boot Notes at the end of this chapter for more information.
<p>12) Verify Jumper Settings</p>	<ul style="list-style-type: none"> • Check the jumper settings before applying power, since one of the jumpers may have fallen off in transit. • Refer to Figure 1-4 for jumper locations and the jumper settings found in Table 1-1 at the end of this chapter for the default jumper settings.

NOTE

For the most current Hardware and BIOS Information, refer to the Hardware Release Notes provided as hard copy in the shipping container.

Connecting Monitor and Power Supply

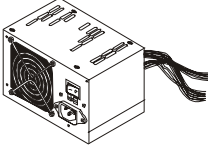
<p>13) Connect the CRT monitor</p> 	<ul style="list-style-type: none"> • Connect the CRT monitor to the video connector at J21 on the edge of the ReadyBoard 800.
<p>14) Connect the power supply</p> 	<ul style="list-style-type: none"> • Connect the ATX power supply to the ATX power adapter connected to J1 and J2 on the edge of the ReadyBoard 800. See Figure 1-4. • Connect all support devices to the ATX power supply. <p>Ensure all of the support devices you have connected to the ReadyBoard 800 (except CRT and 2 1/2" HDD) have good power connections to the ATX power supply or the lab supply.</p>

Applying Power to the ReadyBoard 800

<p>15) Check/Set the Power Supply Input Voltage</p>	<ul style="list-style-type: none"> • If the ATX power supply or lab supply uses auto-ranging operation at 50/60 Hz, skip this step. • Check the input voltage switch on the power supply located on the rear of the ATX power supply just below the power connector. <p>The input voltage switch typically has two positions: 115 or 230 volts – 115 volts is default position.</p>
<p>16) Power up the ReadyBoard 800</p>	<ul style="list-style-type: none"> • Plug the CRT monitor's power cord into an AC outlet and turn it on. • Plug the ATX power supply's power cord into the AC outlet. • If the ATX power supply has separate power switch, turn it on. • Press <u>green</u> Power-On switch connected as part of Utility cable in Step 9, to turn on the ReadyBoard 800 and its ATX power supply.
<p>17) Verify the ReadyBoard 800 powers-up satisfactorily</p>	<ul style="list-style-type: none"> • Verify the ReadyBoard 800 passes POST successfully. • If a bootable device or the desired operating system is not available on one of the boot devices (floppy drive, CD-ROM, or Network {Boot image}) prior to power up, you will see an error message <i>Reboot and Select proper Boot device, or Insert Boot Media in selected Boot device and press a key</i> near the end of the boot process. The boot process stops until you intervene, by doing one of these: <ul style="list-style-type: none"> ◆ Reboot the system and try again, or insert a floppy/CD-ROM into the drive and reboot the system. Go to Steps 18 and 19. ◆ Hold the <u>green</u> Power On switch in for more than 4 seconds to turn off the ATX power supply. <ul style="list-style-type: none"> • Load a bootable device with the OS included. • Press the <u>green</u> Power On switch to re-apply power. • The system should complete the boot process and load the OS. <div data-bbox="630 1654 1409 1900" style="border: 1px solid black; padding: 5px;"> <p>NOTE Ampro does not recommend using a HDD or CF card with a preinstalled OS from another model computer to boot the ReadyBoard 800. This has proven to cause problems or provide unreliable operation. Use a bootable device (floppy, CD-ROM, or Network boot image) to load the desired OS onto the HDD (or CF) and then the drivers, while still attached to the ReadyBoard. Then the HDD or CF can be used to boot the system. Refer to Step 20.</p> </div>

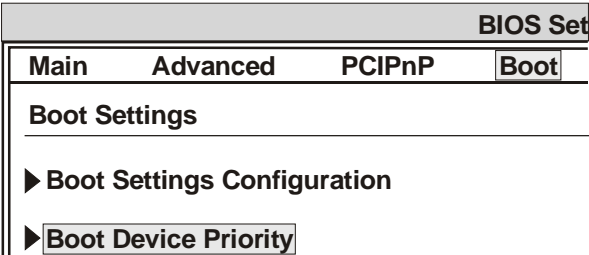
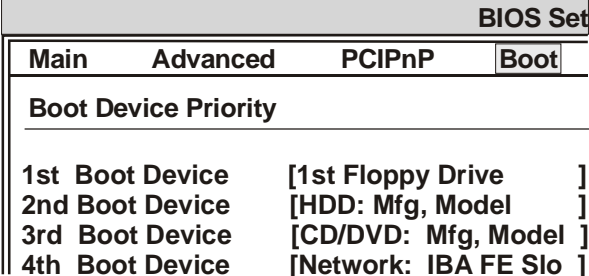
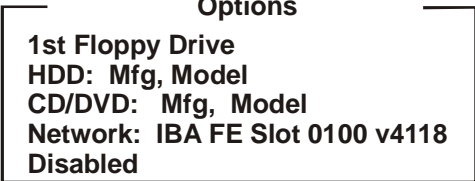
<p>18) Enter BIOS Setup.</p>	<ul style="list-style-type: none"> • Press the key during POST to enter the BIOS Setup Utility. • Use BIOS Setup during the initial boot to set the desired options (time and date, alter the boot order of the floppy drive, CD-ROM, hard disk drive, or select Network: (LAN Boot), etc.). • Refer to Step 19 to alter the boot sequence, while in Setup. 								
<p>19) Alter Boot Order, only if needed</p>	<ul style="list-style-type: none"> • If you need to alter the boot sequence to select a bootable device, perform the items listed in the following sub-steps. 								
<p>The sub-steps listed here show you how to change the Boot Sequence while in the BIOS Setup Utility.</p> <p>a) Select the <i>Boot</i> menu as shown in the figure to the right and scroll down to Boot Device Priority.</p>	 <p>The screenshot shows the BIOS Setup Utility with the 'Boot' menu highlighted. Below the menu, 'Boot Settings Configuration' and 'Boot Device Priority' are visible.</p>								
<p>b) Select <i>Boot Device Priority</i> as highlighted to the right and press <Enter> key.</p> <p>This example assumes 1st Boot Device is a 3 1/2" floppy drive, 2nd Boot is an IDE HDD, 3rd Boot is an IDE CD-ROM, and the 4th Boot is Network (Ethernet 1 - LAN Boot).</p>	 <p>The screenshot shows the 'Boot Device Priority' screen with a list of boot devices and their positions:</p> <table border="1"> <tr> <td>1st Boot Device</td> <td>[1st Floppy Drive]</td> </tr> <tr> <td>2nd Boot Device</td> <td>[HDD: Mfg, Model]</td> </tr> <tr> <td>3rd Boot Device</td> <td>[CD/DVD: Mfg, Model]</td> </tr> <tr> <td>4th Boot Device</td> <td>[Network: IBA FE Slo]</td> </tr> </table>	1st Boot Device	[1st Floppy Drive]	2nd Boot Device	[HDD: Mfg, Model]	3rd Boot Device	[CD/DVD: Mfg, Model]	4th Boot Device	[Network: IBA FE Slo]
1st Boot Device	[1st Floppy Drive]								
2nd Boot Device	[HDD: Mfg, Model]								
3rd Boot Device	[CD/DVD: Mfg, Model]								
4th Boot Device	[Network: IBA FE Slo]								
<p>c) Scroll to 1st Boot Device and press the <Enter> key. The Options list appears with all of the connected devices listed in the popup menu as shown to the right.</p>	 <p>The screenshot shows a popup menu titled 'Options' with the following items:</p> <ul style="list-style-type: none"> 1st Floppy Drive HDD: Mfg, Model CD/DVD: Mfg, Model Network: IBA FE Slot 0100 v4118 Disabled 								
<p>c) Move the CD-ROM up in the Boot Order.</p>	<ul style="list-style-type: none"> • Scroll down to <i>CD/DVD: Mfg, Model</i> and press the <Enter> key. <p>The CD-ROM swaps place with the 1st Floppy Drive, putting the CD-ROM, or any device you select, including Network, in the 1st Boot Device position, while at the same time, putting the 1st Floppy Drive in the 3rd Boot Device position.</p> <ul style="list-style-type: none"> • If you select <i>Disabled</i>, the 1st Floppy Drive moves to the 4th position (last), labeled <i>Disabled</i>, while all other devices move up in the Boot order. • If you are using the LAN Boot feature, refer to the Step e. 								
<p>e) Change the boot order of Network, if using LAN Boot option.</p>	<ul style="list-style-type: none"> • If necessary, enter BIOS Setup and go the Boot menu as described above. • Scroll down to <u>Boot Device Priority</u> and press the <Enter> key. • Scroll to 1st Boot Device listed and press the <Enter> key. • Scroll down to Network (LAN Boot) in the popup menu list and press the <Enter> key, which moves Network to the 1st Boot Device position, while moving the 1st Boot Device to the former Network position. 								

f) Check other settings, and select Save Changes and Exit (This reboots the system).	<ul style="list-style-type: none"> • Check the other BIOS settings, including those related to the floppy drive before exiting BIOS setup. <p>The default settings for the shared floppy/parallel connector set Floppy to [Enabled] and the Parallel (LPT1) port to [Disabled].</p>
g) For LAN Boot, go to PXE BIOS Setup after rebooting	<ul style="list-style-type: none"> • Enter PXE BIOS when you see the following prompt on screen: <i>Initializing Intel (R) Boot Agent Vx.x.xx</i> <i>PXE v2.0 Build xxx (WfM 2.0)</i> Press Ctrl + Alt + B to configure ... • If you miss this message, reboot the system and press Ctrl + S early in the boot process. Make the necessary changes in the PXE BIOS Setup before continuing. • Refer to the LAN Boot Note at the bottom of this page, the contents of Appendix C in the ReadyBoard 800 Reference Manual, and the LAN Boot subdirectory under Software on the ReadyBoard 800 Doc & SW CD-ROM for more information.
20) Install the desired Operating System (OS)	<ul style="list-style-type: none"> • Use the LAN Boot feature to load the boot (OS) image onto the HDD or CF card. Or • Locate the desired Operating System (OS) diskette(s) or CD-ROM and follow the manufacturer's instructions for installing the OS and the necessary drivers. <ul style="list-style-type: none"> ◆ For Windows Operating Systems, some of the necessary drivers may be found on the manufacturer's installation CD-ROM. ◆ For other Operating Systems, some or all of the necessary drivers may be found on the manufacturer's diskette(s) or CD-ROM. • If you require drivers that are not available on the OS manufacturer's diskette(s) or CD-ROM, refer to Installing Software, Drivers, and Utilities in Chapter 2 and the ReadyBoard 800 software directory on the ReadyBoard 800 Doc & SW CD-ROM for instructions.

NOTE

The ReadyBoard 800 ships from the factory configured for CRT support only. Ampro provides LVDS flat panel support for flat panels with specific resolutions.

If you have questions about the flat panels, contact Technical Support through Virtual Technician on the web site for help in setting up the flat panel configurations. Refer also to the ReadyBoard 800 Reference Manual and the Release Notes for additional instructions and information when customizing the BIOS to a particular flat panel.

NOTE

LAN Boot Feature – If you wish to use the LAN Boot feature, there is more to the process than just moving the Ethernet connection to the top of the boot order and selecting the correct PXE BIOS Setup options. You will also need a PXE server with its tools and utilities, which Ampro does not provide. For more information, including the PXE BIOS settings, refer to Appendix C of the ReadyBoard 800 Reference Manual. There is also information in the LAN Boot subdirectory under the Software menu on the ReadyBoard 800 Doc & SW CD-ROM.

Table 1-1. Jumper Settings

Jumper #	Installed	Removed/Installed
JP1 – ISA Bus IRQ (SerIRQ)	Enabled (pins 1-2) **	Disabled (removed) Default
JP2 – CMOS Normal/Clear	Normal (pins 1-2) Default	Clear (pins 2-3, Resets CMOS)
JP3 – CF Master/Slave	Master (pins 1-2)	Slave (removed) Default
JP4 – LVDS Voltage *	Enable +3.3V (pins 1-2) Default	Enable +5V (pins 2-3)
JP7 – CF Voltage Select	Enable +3.3V (pins 1-2) Default	Enable +5V (pins 2-3)
J24 – COM3 RS485	Termination (pins 1-2)	No Termination (removed) Default
J24 – COM4 RS485	Termination (pins 3-4)	No Termination (removed) Default

Notes: If a jumper is removed, it may be placed on one of the jumper pins for safe keeping. The jumpers use 2 mm pin spacing. *This jumper only controls power to the LCD panel, but does not affect signal levels. The ReadyBoard 800 only works with LCD panels that use +5 volt signal levels or +3.3 v panels that are +5 V tolerant. **For full PCI-104 compatibility the jumper should be removed (default setting). Refer to Chapter 2, *Installing MiniModule ISA* and Appendix B in the ReadyBoard 800 Reference Manual for more information.

NOTE

To reset the BIOS because you can't access or boot the system, use the Oops! Jumper referenced in the ReadyBoard 800 Reference Manual. The Oops! Jumper prevents the current BIOS settings in Flash memory from being loaded, forcing the BIOS to use the default settings. The ReadyBoard 800 Reference Manual provides a more detailed discussion of how to create and use the Oops! Jumper.

The Normal/Clear jumper (JP2) resets CMOS, including the time and date of the BIOS.

Table 1-2 list the pin outs of the ATX power adapter provided by Ampro, which has 20-pins, two rows, consecutive (1, 11) with 0.165" (4.2 mm) pin spacing. The connections for the Power In (J2) and Power On (J1) wiring to the ReadyBoard are also listed in the table.

Table 1-2. ATX Power Adapter Cable to ReadyBoard Wiring

ATX Adapter Pin #	Signal	Description	Power In J2 Pin #	Power On J1 Pin #
1, 2, 11	+3.3	+3.3 volts	NC	NC
3, 13, 15, 17	GND	Ground	NC	NC
4 (Red)	+5V	+5 volts +/- 5%	1 (Red)	NC
5 (Blk)	GND	Ground	3 (Blk)	NC
6, 19, 20	+5V	+5 volts +/- 5%	NC	NC
7 (Blk)	GND	Ground	2 (Blk)	NC
8	PW-OK	Power Ok	NC	NC
9 (Purple)	5VSB	+5V, 100 mA Standby	NC	1 (Purple)
10 (Yel)	+12V	+12 volts +/- 5%	4 (Yel)	NC
12	-12V	-12 volts	NC	NC
14 (Gm)	PS-ON	Power Supply On	NC	3 (Grn)
16 (Blk)	GND	Ground line	NC	2 (Blk)
18	-5V	-5.0 volts	NC	NC

Notes: The shaded area denotes power or ground.

Chapter 2 Installing ReadyBoard 800 Options

The procedures in the first part of this chapter describe how to install or remove the ReadyBoard 800 SBC (Single Board Computer) options onto or from the board, including the SODIMM and the compact flash card. Brief instructions for accessing and using the ReadyBoard 800 Doc & SW (Documentation and Software) CD-ROM and a brief description for loading supported Operating Systems is also provided at the end of this chapter.

Memory Installation

The ReadyBoard 800 uses a single SODIMM socket available on the underside of the board. The ReadyBoard 800 supports PC 2700 DDR 333 (166 MHz) or PC 2100 DDR 266 (133 MHz), +2.5V, 200-pin, DDR RAM SODIMM.

NOTE	Ampro recommends using PC 2700 DDR 333 (333 Mbps, 166 MHz, 6 ns), +2.5V, 200-pin, DDR RAM SODIMM for maximum performance. The ReadyBoard will operate acceptably with a PC 2100 DDR 266 (266 Mbps, 133 MHz, 7.5 ns) SODIMM.
-------------	---

Tools Required

Use an anti-static service kit (or the equivalent) to remove or install the SODIMM. An anti-static service kit should include a static-dissipating work surface, a chassis clip lead, and a wrist or ankle strap.

Installation Guidelines

- When handling a SODIMM, observe anti-static discharge precautions to avoid damage.
- The ReadyBoard 800 uses PC 2700 DDR 333 (333 Mbps, 166 MHz) or PC 2100 DDR 266 (266 Mbps, 133 MHz), RAM SODIMMs, which are electrically different from EDO or SDR (Single Stroke) SODIMMs.
- The following DDR SODIMMs sizes are available from Ampro: 128 MB, 256 MB, 512 MB, or 1 GB.
- The ReadyBoard 800 supports up to 1 GB of memory in the 200-pin SODIMM socket.

Removing the SODIMM

Use this procedure to remove the SODIMM from the SODIMM socket on the ReadyBoard 800.

1. Prepare the ReadyBoard 800 for SODIMM removal:
 - ◆ If the ReadyBoard 800 is already prepared for SODIMM removal, with the power turned off, and the power cord disconnected, skip to Step 4.
 - ◆ If the ReadyBoard 800 is operating, power down the system and continue with next step.

CAUTION	To prevent damage to the ReadyBoard 800 and the SODIMM, ensure the power switch on the ATX power supply is turned off and the power cord has been removed from the AC power source. The typical ATX power supply will continue to provide standby current to the board until the power cord is disconnected.
----------------	--

2. Disconnect the ATX power supply's power cord from the AC power source.
3. Disconnect any cables that would prevent you from turning the ReadyBoard 800 over exposing the bottom of the board.

- Turn the ReadyBoard 800 over to access the bottom of the board and lay it on a flat anti-static surface. See Figures 2-1 and 2-2.

CAUTION

To prevent damage to the SODIMM, do not touch the SODIMM until you have discharged yourself and followed good Electrostatic Discharge principals. The SODIMMs are sensitive to static electricity and can be easily damaged by improper handling. Do the following when handling a SODIMM:

Use an anti-static wrist/ankle strap and a grounding mat connected to ground.

Leave the SODIMM in the anti-static bag until you are ready to install it.

Before you remove a SODIMM from the anti-static bag, touch a grounded, unpainted metal surface to discharge any static electricity.

- Locate the SODIMM socket (J22) on the bottom of the ReadyBoard 800. See Figure 2-1.

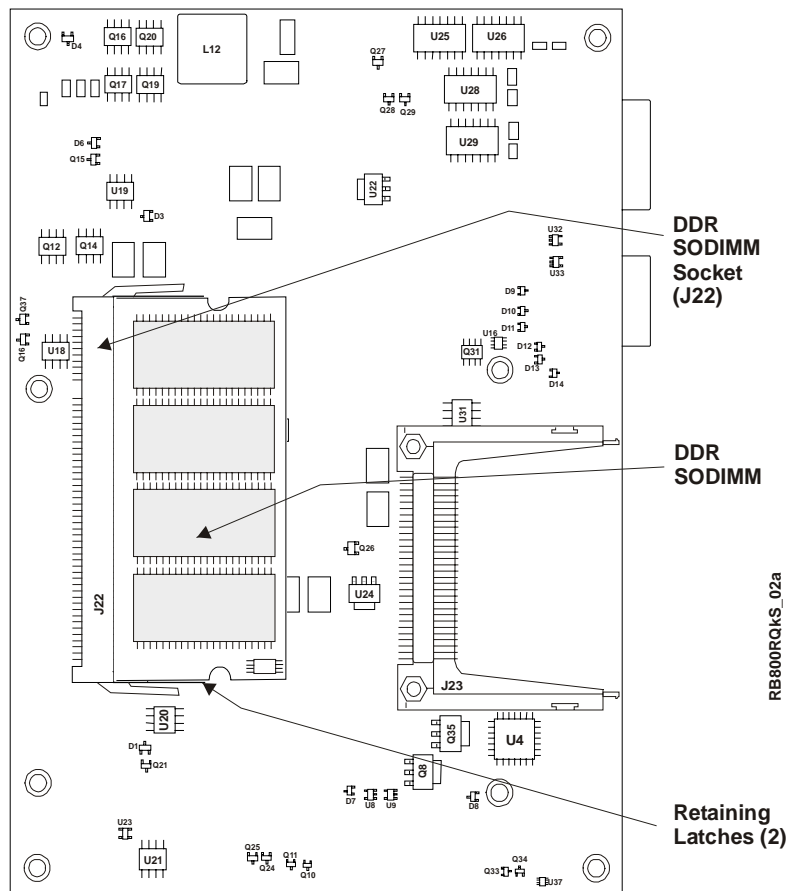

Figure 2-1. ReadyBoard 800 SODIMM Location (Bottom view)

- Open both retaining latches to release the SODIMM from the socket. See Figure 2-2.

The SODIMM will spring up to a 45° angle to the board once you open both retaining latches. If the SODIMM does not spring up to a 45° angle, then the retaining latches have not released the SODIMM from the socket.

- Using the card edges, lift the SODIMM completely away from the socket. See Figure 2-2.
- Place the SODIMM on an anti-static surface or in an anti-static bag.

NOTE If you remove the SODIMM and restore power without a SODIMM installed, you will not see a display and your system will not work properly.

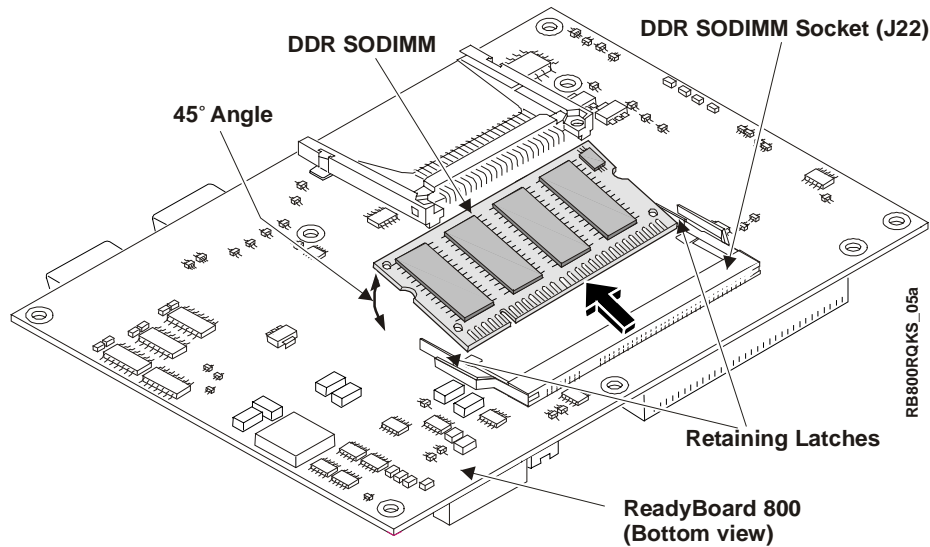

Figure 2-2. Removing SODIMM from Socket

Installing the SODIMM

If you want to install a larger size SODIMM or replace the existing SODIMM, refer to the following procedure.

1. Prepare the ReadyBoard 800 for SODIMM installation:
 - ◆ If the ReadyBoard 800 is already prepared for SODIMM installation, with the power turned off, the power cord disconnected, and an empty SODIMM socket, skip to Step 4.
 - ◆ If the ReadyBoard 800 is operating, power down the system and continue with next step.

CAUTION To prevent damage to the ReadyBoard 800 and the SODIMM, ensure the power switch on the power supply is turned off and the power cord has been removed from the power source. The typical AT power supply will continue to provide standby current to the board until the power cord is disconnected.

2. Disconnect the ATX power supply's power cord from the AC power source.

CAUTION To prevent damage to the SODIMM, do not touch the SODIMM until you have discharged yourself and followed good Electrostatic Discharge principals. The SODIMMs are sensitive to static electricity and can be easily damaged by improper handling. Do the following when handling a SODIMM:

- Use an anti-static wrist/ankle strap and a grounding mat connected to ground.
- Leave the SODIMM in the anti-static bag until you are ready to install it.
- Before you remove a SODIMM from the anti-static bag, touch a grounded, unpainted metal surface to discharge any static electricity.

3. Disconnect any cables that would prevent you from turning the ReadyBoard 800 over exposing the bottom of the board.

4. Turn the ReadyBoard 800 over to access the bottom of the board and lay it on a flat anti-static surface. See Figures 2-1 and 2-3.
5. Remove the existing SODIMM from the SODIMM socket before continuing.

Refer to the Step 4 in the preceding procedure, *Removing the SODIMM*, and follow the remaining steps in that procedure before continuing with the next step in this procedure.

6. Remove the SODIMM from its protective bag, handling the SODIMM by its edges.

NOTE

Ampro recommends using PC 2700 DDR 333 (166 MHz, 6 ns), +2.5V, 200-pin, DDR RAM SODIMM for maximum performance. The PC 2100 DDR 266 (133 MHz) SODIMM will operate acceptably.

7. Ensure there is nothing in the SODIMM socket that would prevent its installation.
8. Insert the SODIMM into the socket at 45° angle to the bottom of the ReadyBoard 800 with the components facing up. See Figure 2-3.

The SODIMM card edge and socket are keyed to install into the socket in only one direction.

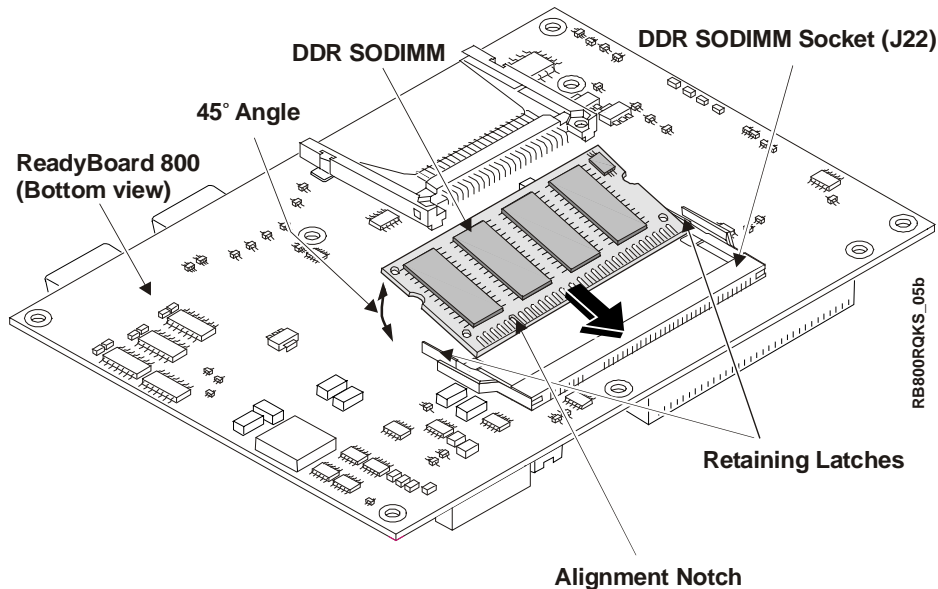

Figure 2-3. Installing SODIMM into Socket

9. Press the edges of the SODIMM down between the latches, until the latches snap into place. See Figure 2-3.

The latches should open to accept the SODIMM without any resistance. If you encounter any resistance, you may not have inserted the SODIMM far enough into the socket.
10. If the retaining latches do not close completely on the SODIMM, remove it and repeat Steps 7 to 9.
11. Turn the ReadyBoard 800 back over onto the bottom of the board, placing it on the work surface.
12. Reconnect any cables you disconnected earlier and verify all other connections to the ReadyBoard 800 are still connected.
13. Reconnect the ATX power supply's power cord to the power source.
14. Restore power to the ReadyBoard 800 and observe the boot screen for new memory recognition.

If the system does not boot or there is a problem recognizing the new memory, the new SODIMM could be defective or the SODIMM was not properly installed or recognized.

Compact Flash Installation

The compact flash socket allows you to substitute solid-state memory card for a conventional hard disk drive. Any of the supported operating system, utilities, drivers, and application programs can easily be run from the compact flash card without modification.

NOTE	You may use Type I or Type II compact flash cards from commercially available suppliers, but check for two CF parameters. The CF parameters to look for include DMA compatibility, such as DMA, UDMA, or non-DMA.. The other major parameter is the bit state storage listed as <code>removable</code> or <code>non-removable</code> . The ReadyBoard 800 supports DMA or UDMA speeds and non-removable bit state storage. Refer to the ReadyBoard 800 Hardware Release Notes and your compact flash card vendor for more information.
-------------	--

Tools Required

The following tools are needed to remove and install the compact flash card onto or off of the ReadyBoard 800 SBC.

- Anti-static service kit - Use a complete anti-static service kit (or the equivalent) to remove or install the compact flash card. A complete anti-static service kit should include a static-dissipating work surface, a chassis clip lead, and a wrist or ankle strap.

Installation Guidelines

The ReadyBoard 800 only supports the compact flash card on the Secondary IDE channel of the EIDE disk controller.

- Configure the compact flash card as [HDD/CF on Sec Master/Slave] in the “Drive Assignment Order” and “Boot Order” as a hard disk drive in the BIOS Setup Utility.
- Use the Master/Slave jumper (JP3) to determine the Master/Slave status of the compact flash card.
- Use the CF Voltage Select jumper (JP7) to determine the CF voltage.
- No two devices on the IDE channel can both be master or both be slave at the same time.

NOTE	Ampro does not recommend using a CF card with a preinstalled OS from another model computer to boot the ReadyBoard 800. This has proven to cause problems or provide unreliable operation. Use a bootable device (floppy or CD-ROM) to load the desired OS onto the CF card and then the drivers, while attached to the ReadyBoard 800. Then the CF card can be used to boot the ReadyBoard 800 without difficulty.
-------------	---

Installing the Compact Flash Card

This procedure describes disconnecting all of the cables to turn the ReadyBoard 800 over, exposing the bottom of the board to install or remove the compact flash card. However, depending on how you have the ReadyBoard 800 mounted and the location of the socket, this may not be necessary. It is possible to install or remove the compact flash card without disconnecting all of the cables and turning the board over, but doing so provides the safest method of checking the condition of the compact flash socket before installing the compact flash card.

You may have to remove the two Ethernet cables and the USB cables to have full access to the compact flash socket and card, but you must power down the system before installing or removing the compact flash card.

NOTE

To simplify this procedure, power down the system and disconnect the two Ethernet cables and the USB cables, which will allow full access to the compact flash socket and card. If you have the ReadyBoard securely mounted, with enough clearance, it is not necessary to turn the board over to access the compact flash card.

However, the procedures described here and on the following pages provide the safest method of checking the condition of the compact flash socket before installing the compact flash card.

1. Prepare the ReadyBoard 800 for compact flash card installation:
 - ◆ If the ReadyBoard 800 is already prepared for compact flash installation, with power disconnected, skip to Step 5.
 - ◆ If the ReadyBoard 800 is connected to power and operating, power down the system and continue with next step.

CAUTION

To prevent damage to the ReadyBoard 800, ensure the power supply is turned off and the power cord has been removed from the power source. The typical ATX power supply will continue to provide standby current to the chassis until the power cord is disconnected.

2. Disconnect the ATX power supply's power cord from the AC power source.

CAUTION

To prevent damage to the ReadyBoard 800 or the compact flash card, do not touch either one until you have discharged yourself and have followed good Electrostatic Discharge principals. The ReadyBoard 800 and the compact flash card are sensitive to static electricity and can be easily damaged by improper handling. Do the following when handling either one:

Use an anti-static wrist/ankle strap and a grounding mat connected to ground.

Leave the compact flash in the anti-static bag until you are ready to install it.

Before you remove a compact flash from the anti-static bag, touch a grounded, unpainted metal surface to discharge any static electricity.

3. Disconnect any cables that would prevent you from turning the ReadyBoard 800 over exposing the bottom of the board.
4. Turn the ReadyBoard 800 over to access the bottom of the board and lay it on a flat anti-static surface. See Figure 2-4.
5. Check for bent pins or debris on the pins of the compact flash socket (J23).
6. Remove the compact flash from its protective bag, handling the compact flash card by its edges.

NOTE

The ReadyBoard 800 supports +5V, Universal (+5V tolerant), or +3.3V compact flash cards. If you are using a newer compact flash card, it will typically work with either 5V or +3.3V, but you can use the CF Voltage Select jumper (JP7) to make the selection. Newer compact flash cards will sense the input voltage and adjust accordingly.

7. Insert the compact flash card into the socket provided by the tabs on the protective cover as shown in Figure 2-1.

The compact flash card edges and the socket are keyed to install in only one orientation.

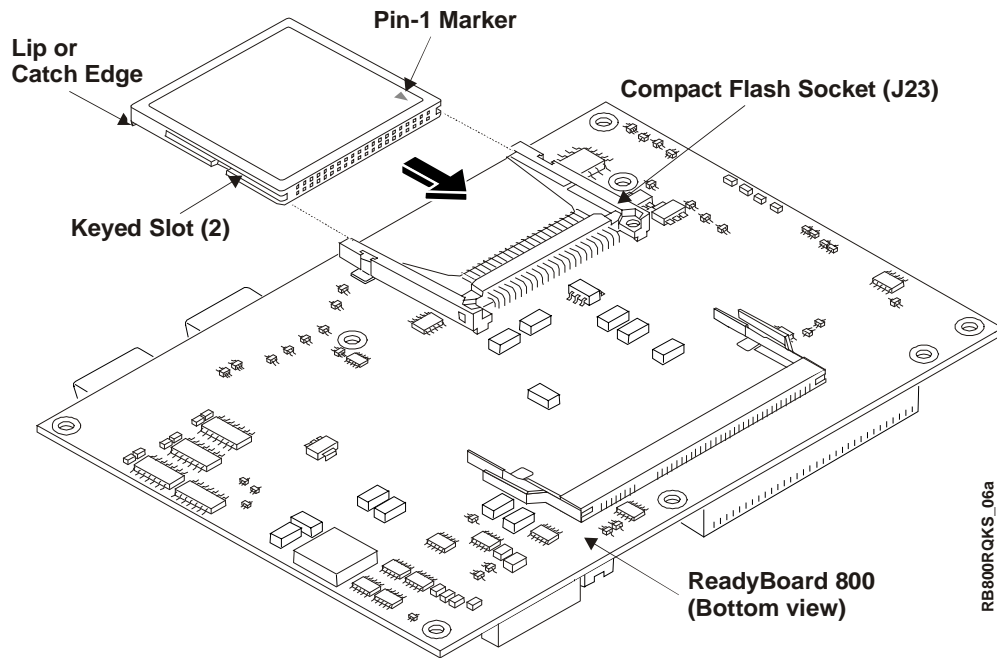

Figure 2-4. Installing the Compact Flash Card

8. Push the compact flash card into the socket until it is firmly into the socket and mates with the pins. See Figures 2-4 and 2-5.
9. Turn the ReadyBoard 800 back over onto the bottom of the board, placing it on the work surface.
10. Reconnect any cables you disconnected earlier and verify all other connections to the ReadyBoard 800 are still connected.
11. Set the Master/Slave jumper (JP3) to the correct master/salve state before continuing. See Table 2-1 and Figure 1-4.
12. Set the CF Voltage jumper (JP7) to the correct voltage for the compact flash before continuing. See Table 2-1 and Figure 1-4.

Table 2-1. Compact Flash Jumper Setting

Jumper #	Installed	Removed
JP3 – CF Master/Slave	Master (pins 1-2)	Slave (removed) Default
JP7 – CF Voltage Select	Enable +3.3V (pins 1-2) Default	Enable +5V (pins 2-3)

13. Plug the ATX power supply's power cord into the AC power source and restore power.
14. Go into the BIOS Setup Utility and change the settings for the compact flash card placing it in the Drive Assignment and the Boot Order.

NOTE

The compact flash must be listed in Drive Assignment and the Boot Order to be recognized by the BIOS. The compact flash can be listed in any of the drive positions.

However, the BIOS does not support a break in the drive order, that is, Drive C can not be listed as [none] when the boot device is Drive D.

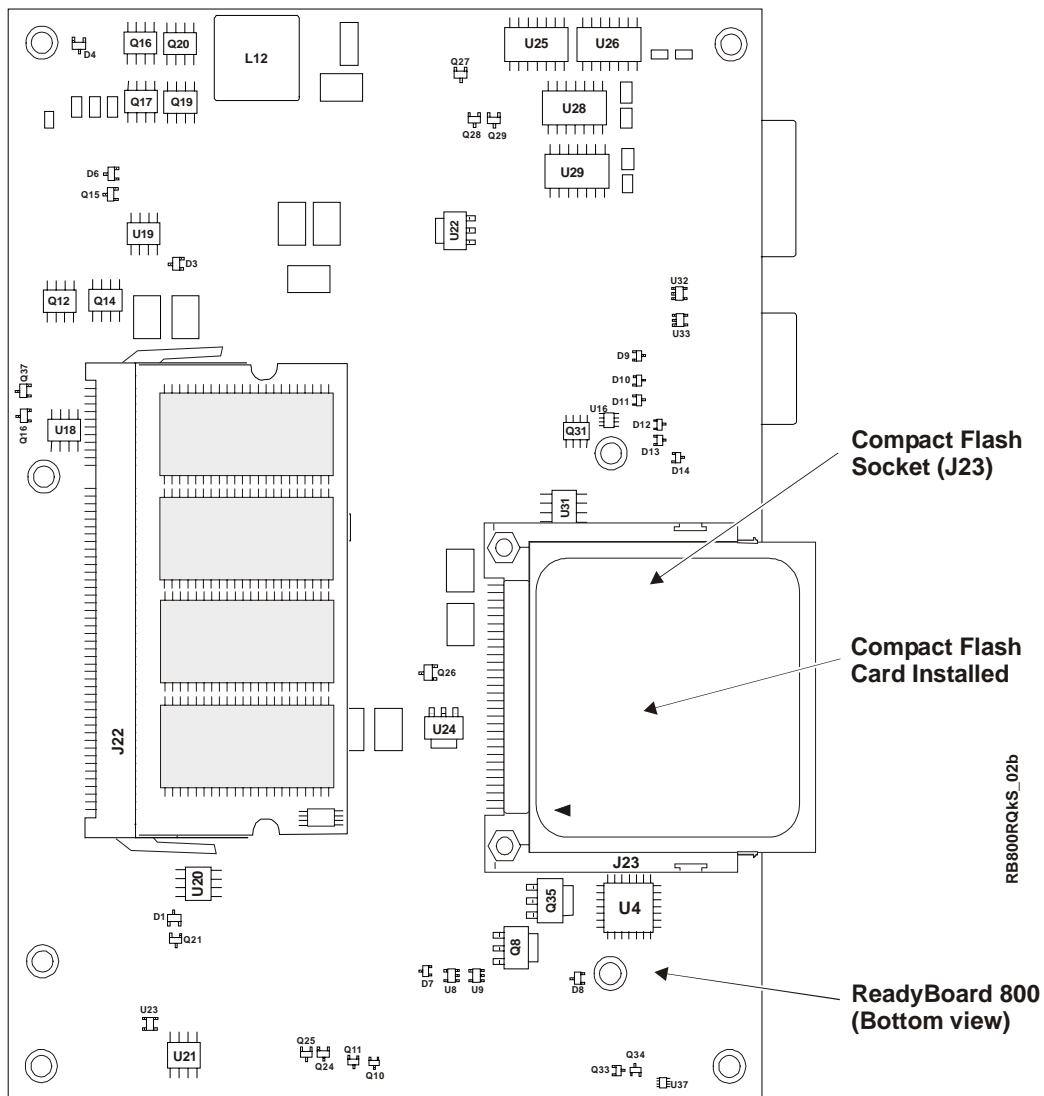

Figure 2-5. Compact Flash Card Installed

Removing the Compact Flash Card

1. Prepare the ReadyBoard 800 for compact flash card removal:
 - ◆ If the ReadyBoard 800 is already prepared for compact flash card removal, with power disconnected, skip to Step 5.
 - ◆ If the ReadyBoard 800 SBC is connected to power and operating, power down the system and continue with the next step.

CAUTION

To prevent damage to the ReadyBoard 800 or the compact flash, ensure the power supply is turned off and the power cord has been removed from the power source. The typical ATX power supply will continue to provide standby current to the chassis until the power cord is disconnected.

2. Disconnect the ATX power supply's power cord from the AC power source.

CAUTION To prevent damage to the ReadyBoard 800 or the compact flash card, do not touch either one until you have discharged yourself and have followed good Electrostatic Discharge principals. The ReadyBoard 800 and compact flash cards are sensitive to static electricity and can be easily damaged by improper handling. Do the following when handling the compact flash cards:

Use an anti-static wrist/ankle strap and a grounding mat connected to ground.

Before you touch the compact flash card, touch a grounded, unpainted metal surface to discharge any static electricity.

3. Disconnect any cables that would prevent you from turning the ReadyBoard 800 over exposing the bottom of the board.
4. Turn the ReadyBoard 800 over to access the bottom of the board and lay it on a flat anti-static surface. See Figure 2-6.
5. Grasp the two sides of the compact flash card or the lip (catch edge) and gently pull it from the compact flash socket and place on anti-static surface or in anti-static bag.

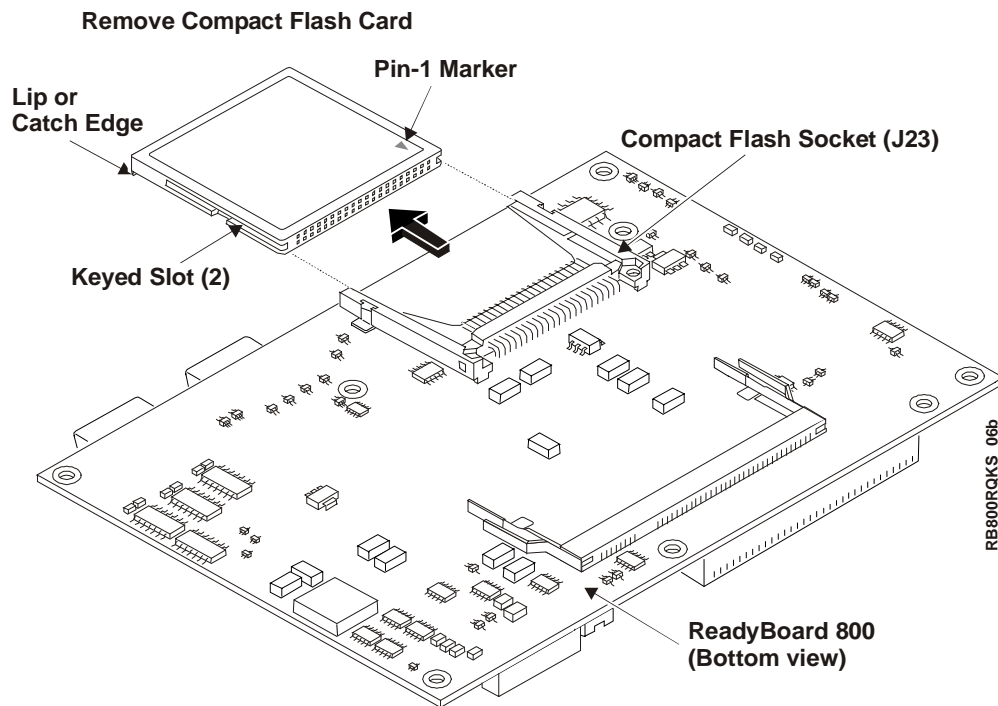

Figure 2-6. Removing the Compact Flash Card

6. Turn the ReadyBoard 800 back over onto the bottom of the board, placing it on the work surface.
7. Reconnect any cables you disconnected earlier and verify all other connections to the ReadyBoard 800 are still connected.
8. If you are not replacing the compact flash card with another compact flash card, ensure you have set JP3 to the correct setting (Master/Slave) before continuing. See Table 2-1 and Figure 1-4.
9. Plug the ATX power supply's power cord into the AC power source and restore power.

Installing MiniModule ISA

The MiniModule™ ISA expansion board allows you to access and use additional PC/104 (ISA) expansion boards with the ReadyBoard 800 using its PCI-104 connector.

Tools Required

The following tools are needed to install or remove the MiniModule ISA expansion board onto or off of the ReadyBoard 800 SBC.

- Small to medium Phillips screwdriver
- Anti-static service kit - Use a complete anti-static service kit (or the equivalent) to remove or install the MiniModule ISA expansion board. A complete anti-static service kit should include a static-dissipating work surface, a chassis clip lead, and a wrist or ankle strap.

Installation Guidelines

The ReadyBoard 800 supports the MiniModule ISA expansion board, which provides PC/104 (ISA Bus) signals to PC/104 expansion boards if connected to the ReadyBoard 800.

- Use the Serial IRQ ISA Bus jumper (JP1) to provide the IRQ signals to the MiniModule ISA board.
- The MiniModule ISA expansion board is configured as a Plug n' Play board in the BIOS Setup.
- The IRQs used for the MiniModule ISA expansion board and any additional PC/104 boards are not available to the Serial 4 (COM4) port.
- Use 0.8" (20 mm) standoffs for the first board off of the ReadyBoard 800. All additional expansion boards above the first board will need the standard 0.6" (15 mm) standoffs.
- The 0.8" (20 mm) and 0.6" (15 mm) standoffs provided by Ampro are threaded for M3 P0.5 screws.

Installing the MiniModule ISA Board

This procedure describes how to install the MiniModule ISA board onto the ReadyBoard 800.

1. ReadyBoard 800 preparation:
 - ♦ If the ReadyBoard 800 is already prepared for MiniModule ISA board installation, with power disconnected, skip to Step 5.
 - ♦ If the ReadyBoard 800 is connected to power and operating, power down the system and continue with next step.

CAUTION	To prevent damage to the ReadyBoard 800, ensure the power supply is turned off and the power cord has been removed from the power source. The typical ATX power supply will continue to provide standby current to the chassis until the power cord is disconnected.
----------------	--

2. Disconnect the ATX power supply's power cord from the AC power source.

CAUTION

To prevent damage to the ReadyBoard 800 or the MiniModule ISA board, do not touch either one until you have discharged yourself and have followed good Electrostatic Discharge principals. The ReadyBoard 800 card is sensitive to static electricity and can be easily damaged by improper handling. Do the following when handling either one:

Always use an anti-static wrist/ankle strap and a grounding mat connected to ground.

Before handling the MiniModule ISA board or removing it from its anti-static container, touch a grounded, unpainted metal surface to discharge any static electricity.

3. Disconnect any cables that would prevent you from accessing the four PC/104 mounting post locations and the PCI-104 connector on the ReadyBoard 800.
4. Mount the four 0.8" (20 mm) standoffs onto the ReadyBoard 800 at the four PC/104 mounting holes on the board. See Figure 2-7.

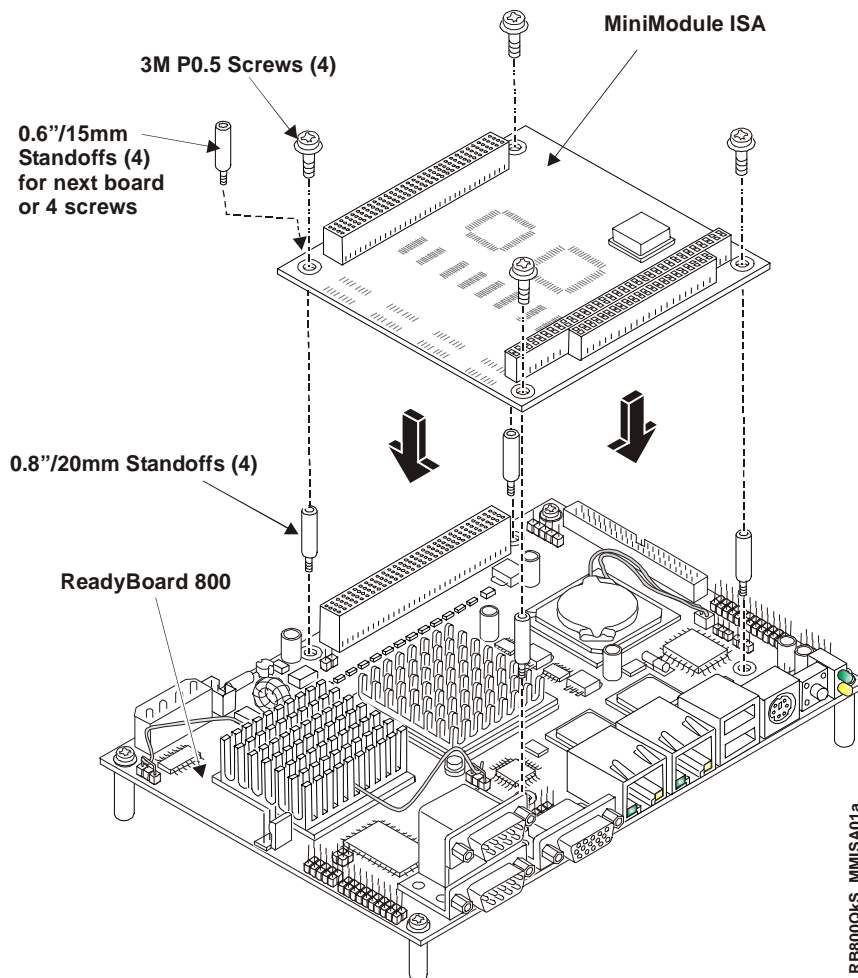

Figure 2-7. Installing the MiniModule ISA Expansion Board

5. Position the MiniModule ISA board over the PCI-104 connector on the ReadyBoard 800. Match the connector on the bottom of the MiniModule ISA board with the PCI-104 connector on the ReadyBoard 800, as shown in Figure 2-7.

6. Lower the MiniModule ISA board onto the ReadyBoard 800 connector while matching connectors.
7. Slowly work the connectors together to prevent bending any of the pins.
8. Install the screws (4) through the MiniModule ISA board into the standoffs (4) to secure it to the ReadyBoard 800 as shown in Figure 2-7.
 - ♦ If you are installing another PC/104 module onto the MiniModule ISA board, use four 0.6" (15 mm) standoffs instead of screws to separate the two boards.

NOTE	The 0.8" (20 mm) and 0.6" (15 mm) standoffs provided by Ampro are threaded for M3 P0.5 screws (Metric 3, 0.5 pitch).
-------------	--

- ♦ If you are installing another PC/104 module onto the MiniModule ISA board, refer to the PC/104 module's installation instructions before continuing.
9. Reconnect any cables you disconnected earlier and verify all other connections to the ReadyBoard 800 are still connected.
 10. Plug the ATX power supply's power cord into the AC power source and restore power.

Removing the MiniModule ISA Board

This procedure describes how to remove the MiniModule ISA board from the ReadyBoard 800. You will typically have other PC/104 modules installed onto the MiniModule ISA board while it is connected to the ReadyBoard 800. You will typically separate and remove those board(s) in the same manner as you would with MiniModule ISA board.

1. Remove the four screws (or standoffs) holding the MiniModule ISA board to the ReadyBoard 800. See Figure 2-7.
2. Lift up slightly at the first corner of the module as shown in Figure 2-8.

This corner was chosen because of the corner's proximity to the PCI-104 connector.

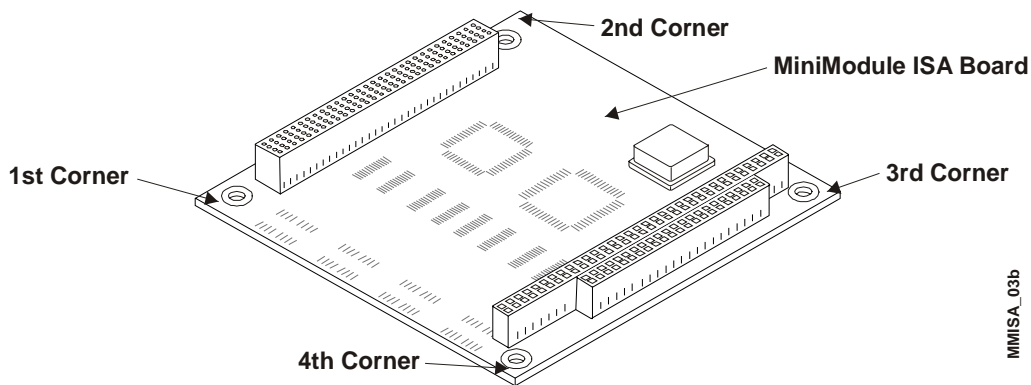

Figure 2-8. Removing the MiniModule ISA Board

3. Lift up slightly at the second corner of the module as shown in Figure 2-8.
4. Lift up slightly at the third corner of the module as shown in Figure 2-8.
5. Lift up slightly at the fourth corner of the module as shown in Figure 2-8.
6. Repeat Steps 2-5, until you have removed the MiniModule ISA board from the ReadyBoard 800.
7. Handle the MiniModule ISA board by its edges and place it on an anti-static mat until you are ready to re-install the MiniModule ISA board.

Installing Software, Drivers, and Utilities

To install the operating system and respective software drivers, refer to the following procedure.

1. Install the desired Operating System (OS) and related drivers from the source files (LAN Boot) or the manufacturer's diskette(s) or CD-ROM.
 - ◆ If you are using the LAN Boot feature to load the boot (OS) image, skip the other information in this Step. Steps 2 to 5 describe how to access and use the ReadyBoard 800 Doc & SW CD-ROM, which you may find helpful.

Follow the manufacturer's instructions to install the desired OS and respective drivers.

- ◆ For Windows Operating Systems, some of the necessary drivers may be found on the manufacturer's installation diskette or CD-ROM. If more software drivers are needed, refer to the ReadyBoard 800 Doc & SW CD-ROM.
 - ◆ For other Operating Systems, some or all of the necessary drivers may be found on the manufacturer's installation diskette(s) or CD-ROM. If not, refer to the ReadyBoard 800 Doc & SW CD-ROM.
2. Run the ReadyBoard 800 Doc & SW CD-ROM to access the ReadyBoard documentation, various utilities, and OS drivers not on the manufacturer's diskette(s) or CD-ROM.

The ReadyBoard 800 Doc & SW CD-ROM will operate on any Windows PC, allowing you to view, download, or print the contents of the CD-ROM. This includes the *ReadyBoard 800 QuickStart Guide*, *ReadyBoard 800 Reference Manual*, Release Notes, software drivers and various utilities.

NOTE

You must have an Internet browser to view the main menu and make selections (examples: Microsoft Internet Explorer 4.x, or greater, Netscape Navigator version 4.x, or greater, or the equivalent on a PC). Software download links are provided for Adobe Acrobat Reader version 4.x or greater to view the manuals and documents.

An Internet connection is required for the Adobe Acrobat link or access to the Ampro web site.

The ReadyBoard 800 Doc & SW CD-ROM should auto-start, but if it does not, go to the root level of the CD-ROM and locate the index.htm by:

- a. Selecting Run from the Start menu in any Windows PC.
- b. Browsing the contents of the CD-ROM until you find the index.htm at the root level.
- c. Select this file and press OK to start the CD-ROM.

The CD-ROM starts and opens the main menu of the CD-ROM.

3. Select from the directories as shown below:
 - ◆ ReadyBoard 800 Documentation (Software Release Notes, ReadyBoard 800 Reference Manual and QuickStart Guide)
 - ◆ ReadyBoard 800 Software (Board Support Packages for supported operating systems, drivers, miscellaneous source code and examples, LAN Boot information, etc.)

There are directories and subdirectories under these topics that should provide you with the needed manuals, utilities, and tools not explained earlier.

4. Install any special OS drivers not found on the manufacturer's diskette(s) or CD-ROM.

Refer to the directories on the ReadyBoard 800 Doc & SW CD-ROM for instructions on installing the special drivers for the desired OS.

If the desired drivers can not be found, contact Ampro through the Virtual Technician on the web site with a request for the driver(s). Refer also to the Appendix A, Technical Support for more information.

5. Install any utilities or other development tools you may need from the ReadyBoard 800 Doc & SW CD-ROM.

Refer to the directories on the ReadyBoard 800 Doc & SW CD-ROM for instructions on installing and using the utilities or development tools for the desired OS.

Appendix A Technical Support

Ampro Computers, Inc. provides a number of methods for contacting Technical Support listed below in Table A-1. Requests for support through the Virtual Technician are given the highest priority, and usually will be addressed within one working day.

- Ampro Virtual Technician – This is a comprehensive support center designed to meet all your technical needs. This service is free and available 24 hours a day through the Ampro web site at <http://ampro.custhelp.com>. This includes a searchable database of Frequently Asked Questions, which will help you with the common information requested by most customers. This is a good source of information to look at first for your technical solutions. However, you must register online before you can log in to access this service.
- Personal Assistance – You may also request personal assistance by going to the "Ask a Question" area in the Virtual Technician. Requests can be submitted 24 hours a day, 7 days a week. You will receive immediate confirmation that your request has been entered. Once you have submitted your request you can go to the "My Stuff" area and log in to check status, update your request, and access other features.
- Embedded Design Resource Center – This service is also free and available 24 hours a day at the Ampro web site at <http://www.ampro.com>. However, you must be registered online before you can login to access this service.

The Embedded Design Resource Center was created as a resource for embedded system developers to share Ampro's knowledge, insight, and expertise gained from years of experience. This page contains links to White Papers, Specifications, and additional technical information.

Table A-1. Technical Support Contact Information

Method	Contact Information
Virtual Technician	http://ampro.custhelp.com
Web Site	http://www.ampro.com
Standard Mail	Ampro Computers, Incorporated 5215 Hellyer Avenue San Jose, CA 95138-1007, USA

