



**MiniModule™ USB2  
PC/104-Plus Expansion Module  
QuickStart Guide and  
Reference Manual**

**P/N 5001684A Revision A**

## Notice Page

---

### NOTICE

No part of this document may be reproduced, transmitted, transcribed, stored in a retrieval system, or translated into any language or computer language, in any form or by any means, electronic, mechanical, magnetic, optical, chemical, manual, or otherwise, without the prior written permission of Ampro Computers, Incorporated.

### DISCLAIMER

Ampro Computers, Incorporated makes no representations or warranties with respect to the contents of this manual or of the associated Ampro products, and specifically disclaims any implied warranties of merchantability or fitness for any particular purpose. Ampro shall under no circumstances be liable for incidental or consequential damages or related expenses resulting from the use of this product, even if it has been notified of the possibility of such damages. Ampro reserves the right to revise this publication from time to time without obligation to notify any person of such revisions. If errors are found, please contact Ampro at the address listed below on the Notice page of this document.

### TRADEMARKS

The Ampro logo is a registered trademark, and EnCore, CoreModule, Little Board, and MiniModule are trademarks of Ampro Computers, Inc. All other marks are the property of their respective companies.

### REVISION HISTORY

Revision	Reason for Change	Date
A	Initial Release	Aug/03

Ampro Computers, Incorporated  
5215 Hellyer Avenue  
San Jose, CA 95138-1007  
Tel. 408 360-0200  
Fax 408 360-0222  
www.ampro.com

© Copyright 2003, Ampro Computers, Incorporated

## Audience Assumptions

---

This reference manual is for the person who designs computer related equipment, including but not limited to hardware and software design and implementation of the same. Ampro Computers, Inc. assumes you are qualified in designing and implementing your hardware designs and its related software into your prototype computer equipment.

# Contents

---

<b>Chapter 1 About This Manual</b> .....	<b>1</b>
Purpose .....	1
Reference Material .....	1
Related Ampro Products .....	2
<b>Chapter 2 Setting Up the MiniModule USB2</b> .....	<b>5</b>
Using the MiniModule USB2 QuickStart Kit .....	5
Requirements .....	5
What's in the Box .....	5
Setup Steps .....	6
Preparations .....	6
Setting Up the MiniModule USB2.....	6
Setting Up the Target System .....	7
Mounting the Module onto the Target System .....	8
Applying Power to the Target System.....	10
Accessing Drivers and Documentation .....	11
<b>Chapter 3 Product Overview</b> .....	<b>13</b>
PC/104-Plus Architecture .....	13
Product Description .....	14
Module Features .....	14
Block Diagram .....	15
Major Integrated Circuits (ICs) .....	16
Connectors and Switches.....	17
Connector Definitions .....	17
Selection Switch .....	18
Specifications.....	19
Physical Specifications.....	19
Mechanical Specifications .....	19
Power Specifications .....	20
Environmental Specifications .....	20
Thermal/Cooling Requirements.....	20
<b>Chapter 4 Hardware Description</b> .....	<b>21</b>
Overview .....	21
PC/104-Plus Interface (P3).....	21
PC/104 Bus Interface (P1A,B,C,D).....	26
USB Interface (J6, J7, J8, J9).....	29
Auxiliary Power Interface (J5).....	31
<b>Appendix A Technical Support</b> .....	<b>33</b>
Contacting Support .....	33
Getting Updates.....	33
<b>Index</b> .....	<b>35</b>

**List of Figures**

Figure 2-1. CoreModule Target System Example.....	7
Figure 2-2. Little Board Target System Example.....	7
Figure 2-3. MiniModule USB2.....	8
Figure 2-4. Installing MiniModule USB2 on CoreModule Target.....	9
Figure 2-5. Installing MiniModule USB2 on Little Board Target.....	10
Figure 3-1. CoreModule Target Stackthrough Connections.....	13
Figure 3-2. Little Board Target Stackthrough Connections.....	14
Figure 3-3. MiniModule USB2 Block Diagram.....	15
Figure 3-4. MiniModule USB2 (Top View).....	16
Figure 3-5. Connector Locations (Top View).....	17
Figure 3-6. Device ID Selection Switch (Top View).....	18
Figure 3-7. Mechanical Dimensions (Top View).....	19

**List of Tables**

Table 2-1. Device ID Select Position Switch (S1).....	9
Table 3-1. Major Integrated Circuit Descriptions and Function.....	16
Table 3-2. Connector Descriptions.....	17
Table 3-3. Device ID Selection Switch (S1).....	18
Table 3-4. Weight and Footprint Dimensions.....	19
Table 3-5. Power Supply Requirements.....	20
Table 3-6. Environmental Requirements.....	20
Table 4-1. PC/104-Plus Pin/Signal Descriptions (P3).....	21
Table 4-2. PC/104 Bus Interface Pin/Signal Descriptions (P1A).....	26
Table 4-3. PC/104 Bus Interface Pin/Signal Descriptions (P1B).....	27
Table 4-4. PC/104 Bus Interface Pin/Signal Descriptions (P1C).....	28
Table 4-5. PC/104 Bus Interface Pin/Signal Descriptions (P1D).....	28
Table 4-6. USB Port 0 Interface Pin/Signal Descriptions (J6).....	29
Table 4-7. USB Port 1 Interface Pin/Signal Descriptions (J7).....	29
Table 4-8. USB Port 2 Interface Pin/Signal Descriptions (J8).....	30
Table 4-9. USB Port 3 Interface Pin/Signal Descriptions (J9).....	30
Table 4-10. Auxiliary Power Interface Pins/Signals (J5).....	31
Table 4-11. Auxiliary Power Pin Arrangement (J5).....	31
Table A-1. USA Technical Support Contact Information.....	33

# Chapter 1 About This Manual

---

## Purpose

This manual provides information regarding the installation and setup of the MiniModule USB2 (USB 2.0), as well as sufficient technical information to permit embedded system designers to easily expand their embedded systems based on any additional design requirements.

<b>NOTE</b>	The MiniModule USB2 is designed for CPU modules with PC/104-Plus only. PC/104 only CPU modules are not supported.
-------------	---

**Information provided** in the QuickStart Setup Chapter (2) of this manual includes:

- Removing the MiniModule USB2 board from the shipping container
- Inventorying the accessories
- Connecting the MiniModule USB2 board to the respective target board
- Powering up the MiniModule USB2 board with the target board

**Information provided** in the Reference Chapters (1, 3, and 4) of this manual include:

- MiniModule USB2 board Specifications
- Environmental requirements
- Major integrated circuits (chips) and features implemented
- MiniModule USB2 board connector/pin numbers and definition

**Information not provided** in this manual includes:

- Detailed chip specifications
- Internal component operation
- Internal registers or signal operations
- Bus or signal timing for industry standard busses and signals

## Reference Material

The following list of reference materials may be helpful for you to complete your custom design successfully. Most of this reference material is also available on the Ampro web site in the Embedded Design Resource Center. The Embedded Design Resource Center was created for the benefit of embedded system developers to share Ampro's knowledge, insight, and expertise gained from years of experience.

### Specifications

- PC/104 Specification Revision 2.4, August 2001
- PC/104-Plus Specification Revision 1.2, August 2001

For latest revision of either PC/104 specifications, contact the PC/104 Consortium, at:

Web site: [http:// www.pc104.org](http://www.pc104.org)

- PCI 2.2 Compliant Specification, Revision 2.2, December 18, 1998

For latest revision of the PCI specifications, contact the PCI Special Interest Group at:

Web site: [http:// www.pcisig.com](http://www.pcisig.com)

- Universal Serial Bus (USB) Specification, Revision 2.0, April 27, 2000

For the latest revision of the USB specifications, contact the USB Implementers Forum, Inc. (USB-IF) at:

Web site: [http:// www.usb.org](http://www.usb.org)

Chip specifications used in the MiniModule USB2 expansion board:

- NEC and the chip,  $\mu$ PD720101, used for the USB 2.0 host controller

Web site: [http:// www.nec.com](http://www.nec.com)

## Related Ampro Products

The following items are directly related to successfully using the Ampro product you have just purchased or plan to purchase. Ampro highly recommends that you purchase and utilize a MiniModule USB2 QuickStart Kit simultaneously with the design of your product.

### MiniModule Support Products

- MiniModule USB2 QuickStart Kit (QSK)

The MiniModule USB2 QuickStart Kit includes the MiniModule USB2 expansion board, documentation, and drivers for Ampro supported operating systems on the MiniModule Documentation and Support Software (Doc & SW) CD-ROM.

### Other MiniModule Products

- MiniModule™ PCC II Expansion Board – This MiniModule is a compact, low power PC/104 peripheral board with two PCMCIA card sockets for connecting one or two PCMCIA memory or peripheral cards to an Ampro embedded system. Up to two MiniModule PCC IIs can be installed in a system. This MiniModule allows the integration of PCMCIA memory cards and PCMCIA peripheral cards into systems based on Ampro's CoreModule™ and Little Board™ CPUs.

The MiniModule PCC II supports memory cards such as Flash EPROM, SRAM, and One Time Programmable EPROM (OTPROM) and I/O devices such as modems, LAN adapters, or PCMCIA-ATA (IDE) drives. PCMCIA XIP (eXecute In Place) is fully supported. The MiniModule PCC II has two PCMCIA card sockets that are compatible with Type I, Type II, Type III, and Type IV cards. The MiniModule PCC II can be used with any PC/104 compatible CPU including the Ampro CoreModule or Little Board families (See Other Ampro Products).

The MiniModule PCC II also comes in a local and remote version where the Local Version is used as a stand-alone board, mounted directly on a CPU module. The Remote Version is connected to the CPU remotely through an additional board, the Buffer Module and its ribbon cable. The Remote Version can be mounted up to 14 inches from the Buffer Module and CPU.

- MiniModule™ ESB Expansion Board – This MiniModule is a multipurpose communications board with one Ethernet port, two serial ports, and one byte-wide socket. The MiniModule ESB size and expansion bus connectors conform to the PC/104-Plus standard and can be installed directly on Ampro's Little Board™ and CoreModule™ computer systems supporting the PC/104-Plus expansion bus. The MiniModule ESB supports one 10/100BaseT Ethernet port, two 16C550-type RS232 Serial Ports (with optional RS485 and TTL interfaces) and the byte-wide socket supports Disk-On-Chip, flash EPROM, SRAM, or NVRAM.

- MiniModule™ PCC III Expansion Board – This MiniModule is a compact, low power PC/104-Plus peripheral board with two PCMCIA card sockets for connecting one or two PCMCIA memory or peripheral cards to an Ampro CPU module or single board computer. Up to two MiniModule PCC III boards can be installed in a system. This MiniModule allows the integration of commercially available 16-bit or 32-bit PC cards or PCMCIA memory cards and peripheral cards.

The MiniModule PCC III supports memory cards such as EPROM, SRAM, and One Time Programmable EPROM (OTPROM) and I/O devices such as 802.11 Wireless LAN (Wi-Fi®) cards, modems, 10/100BaseT LAN adapters, or PCMCIA-ATA (IDE) drives. PCMCIA XIP (eXecute In Place) is fully supported. The MiniModule PCC III has two PCMCIA card sockets that are compatible with Type I, Type II, Type III, and Type IV cards. The MiniModule PCC III can be used with any PC/104-Plus compatible CPU including the Ampro CoreModule or Little Board families (See Other Ampro Products).

- MiniModule™ 1394 Expansion Board – This MiniModule is a compact, low power PC/104-Plus peripheral board with two IEEE 1394 (FireWire™) interface connectors. The MiniModule 1394 supports the IEEE 1394 standard (1394-1995 and 1394a-2000), including a host controller at speeds of 100, 200, or 400Mbps. This allows easy integration of cameras or other FireWire devices, with hot insertion or removal of any IEEE 1394 cables.

### Other Ampro Products

- CoreModule™ Family – These complete embedded-PC subsystems on single PC/104 or PC/104-Plus form-factor (3.6x3.8 inches) boards feature 486 and Mobile Pentium CPUs. Each CoreModule includes a full complement of PC core logic functions, plus disk controllers, and serial and parallel ports. Some boards also include CRT and flat panel graphics controllers or an Ethernet interface. The CoreModules also come with built-in extras to meet the critical reliability requirements of embedded applications. These include onboard solid state disk compatibility, watchdog timer, smart power monitor, and other embedded-PC BIOS enhancements.
- EnCore™ Family - These high-performance, compact, modular CPU solutions use various processor technologies including Intel x86, MIPS, and PowerPC architectures to plug into your custom logic board. Each EnCore module provides standard peripherals, including IDE, floppy drive interface, PCI bus, serial, parallel, PS/2 keyboard and mouse interfaces, 10/100BaseT Ethernet, and USB ports. Some EnCore modules also provide video and AC97 sound. Depending on the model, EnCore modules can hold between 16MB and 512MB of SODIMM SDRAM memory.
- Little Board™ Family – These high-performance, highly integrated single board computers use the EBX form factor (5.75x8.00 inches), and are available with 486, Mobile Pentium, Pentium II, Pentium III, and Celeron processors. The EBX-compliant Little Board single board computers offer functions equivalent to a complete laptop or desktop PC system, plus several expansion cards. Built-in extras to meet the critical requirements of embedded applications include onboard solid state disk capability, watchdog timer, smart power monitor, and other embedded-PC BIOS enhancements.



# Chapter 2 Setting Up the MiniModule USB2

---

## Using the MiniModule USB2 QuickStart Kit

This QuickStart setup chapter provides the most efficient way to set up your MiniModule USB2 board installed on Ampro's target board (CoreModule or Little Board). The instructions provided in this setup chapter include:

- Removing the MiniModule USB2 board from the shipping container
- Inventorying the accessories
- Connecting the MiniModule USB2 board to the respective target board
- Powering up the MiniModule USB2 board

Information not provided in this setup chapter includes:

- MiniModule USB2 board specifications
- Environmental requirements
- MiniModule USB2 board connector pin numbers and definitions
- Supplied software driver use and programming considerations

## Requirements

The following devices are needed to make full use of the MiniModule USB2 and the target board.

- Target System (PC/104-Plus compliant)
  - ◆ Ampro CoreModule CPUs
  - ◆ Ampro Little Board SBCs
  - ◆ 3rd party target systems
- Power supply:
  - ◆ AT or lab power supply – A target system power supply is required to provide power to the target board and the MiniModule USB2 board.
  - ◆ Optional power cable for auxiliary +5V and +12V input
- Boot Device for the target system
- Optional Devices/Connections for Target System
  - ◆ Display, keyboard, mouse, etc.
  - ◆ Ethernet connection

## What's in the Box

Refer to the QuickStart Kit Contents sheet for a list of the items in the shipping container.

## Setup Steps

It is important to follow the setup steps in this chapter in the exact order listed here, but skip any steps that do not apply to your situation. References are provided to chapters within this guide or other Ampro manuals, which provide more information about installation and use of the MiniModule USB2 board.

### Preparations

1) Open shipping box.	<ul style="list-style-type: none"> <li>• Locate the QuickStart Kit Contents sheet.</li> <li>• Unpack the contents of the shipping box.</li> </ul>
2) Verify Contents.	<ul style="list-style-type: none"> <li>• Verify the contents of the shipping box against the QuickStart Kit Contents sheet included with your MiniModule USB2 shipping box.</li> <li>• If anything is missing or damaged, contact your sales representative or Ampro Technical Support.</li> </ul>
3) Support Documentation (MiniModule Documentation & Support Software (Doc & SW) CD-ROM)	<ul style="list-style-type: none"> <li>• MiniModule USB2 QuickStart Setup Chapter 2 describes how to setup, install, and power up the MiniModule USB2 board found in the QuickStart Kit. This chapter is found in the <i>MiniModule USB2 QuickStart Guide and Reference Manual</i> found under the MiniModule USB2 menu on the MiniModule Documentation &amp; Support Software CD-ROM (MiniModule Doc &amp; SW CD-ROM) as a PDF file.</li> <li>• MiniModule USB2 Reference Material Chapters 1, 3, and 4 describe the MiniModule USB2 board in more detail and provide more reference information. These chapters are found in the <i>MiniModule USB2 QuickStart Guide and Reference Manual</i> found under the MiniModule USB2 menu on the MiniModule Documentation &amp; Support Software CD-ROM (MiniModule Doc &amp; SW CD-ROM) as a PDF file.</li> </ul>

### Setting Up the MiniModule USB2

<b>CAUTION</b>	<p>To prevent damage to the electronic components on the MiniModule USB2 board or the target system, do not handle the boards until you have used Electrostatic Discharge precautions.</p> <p>Always touch a grounded, unpainted metal surface before touching the MiniModule USB2 board or the target system board.</p> <p>Always use an anti-static wrist or ankle strap connected to a grounding mat, which has static-dissipating characteristics and attached to earth ground.</p>
----------------	---

4) Select workbench location	<ul style="list-style-type: none"> <li>• The workbench location should be flat, clear of debris, and have a static-free mat (or the equivalent) to place the target board and MiniModule USB2 onto for setup and operation (including the target system power supply, peripherals, and support devices).</li> </ul>
5) Connect an ESD strap to your body	<ul style="list-style-type: none"> <li>• Connect an ESD strap between your body (wrist or ankle) and ground or the static-free mat.</li> </ul> <p>If you do not have your own ESD strap, an ESD kit is provided in the QuickStart Kit with an anti-static wrist strap.</p>

## Setting Up the Target System

	<ul style="list-style-type: none"> <li>• If the target system has already been setup on the workbench for installation of the MiniModule USB2 board, skip this section and go to Step 9.</li> <li>• Refer also to the target system QuickStart Guide for the install instructions referenced in the following steps. See Figures 2-1 and 2-2 for examples of CoreModule and Little Board Target Systems.</li> </ul>
6) Place the target system on the workbench	<ul style="list-style-type: none"> <li>• If the target system is in its protective plastic case, remove from the plastic case and place it on a flat, static-free work surface.</li> </ul>
7) Connect all cables to the target system	<ul style="list-style-type: none"> <li>• This includes connecting cables used for any peripherals, boot devices, and the power supply used for the target system.</li> </ul>
8) Connect the peripherals and boot devices	<ul style="list-style-type: none"> <li>• This includes the keyboard, mouse, monitor, floppy drive, and IDE devices.</li> </ul>
9) Connect the power supply	<ul style="list-style-type: none"> <li>• Connect the power supply to the target system, but <b>do not turn</b> it on, or connect the power cord to the AC power source yet.</li> </ul>

### CAUTION

To prevent damage to the MiniModule USB2 board or the target system, do not connect the power cord to the AC power source or apply power to the target system, until you have completely installed the MiniModule USB2 onto the target system. The typical AT power supply will supply standby current to the target system as long as the power cord is connected.

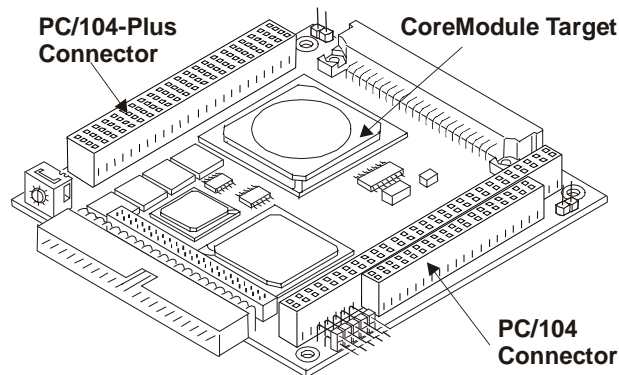

Figure 2-1. CoreModule Target System Example

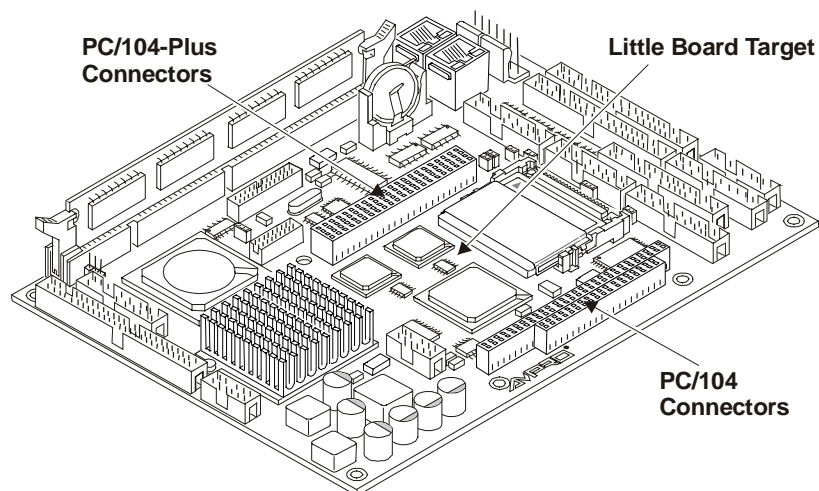

Figure 2-2. Little Board Target System Example

## Mounting the Module onto the Target System

**CAUTION** To prevent damage to the MiniModule USB2 board or the target board, do not attempt to mount the MiniModule USB2 to a non-standard PC/104-Plus target board. The MiniModule USB2, Little Board, and CoreModule boards conform to the standard PC/104-Plus mounting hole and board dimensions. Details about mounting hole positions, sizes, and board dimensions are provided in the Chapter 3, *Product Overview* later in this manual.

10) Unpack the MiniModule USB2 board.	<ul style="list-style-type: none"> <li>Remove the MiniModule USB2 board from its protective plastic case and place it on a flat, static-free work surface.</li> </ul>
11) Check the MiniModule USB2 for bent pins	<ul style="list-style-type: none"> <li>Ensure there are no bent or broken pins on the underside of the board at the PC/104 connector, before attempting to install the MiniModule USB2 board on the target system.</li> </ul>
12) Position the MiniModule USB2 over the target system	<ul style="list-style-type: none"> <li>The MiniModule USB2 must be positioned over the PC/104 and PC/104-Plus connectors on the target system. See Figures 2-1 to 2-4.</li> </ul> <p>Typically the MiniModule USB2 board is installed on the top side of the target system, but in some cases, it may be installed underneath the target system.</p>

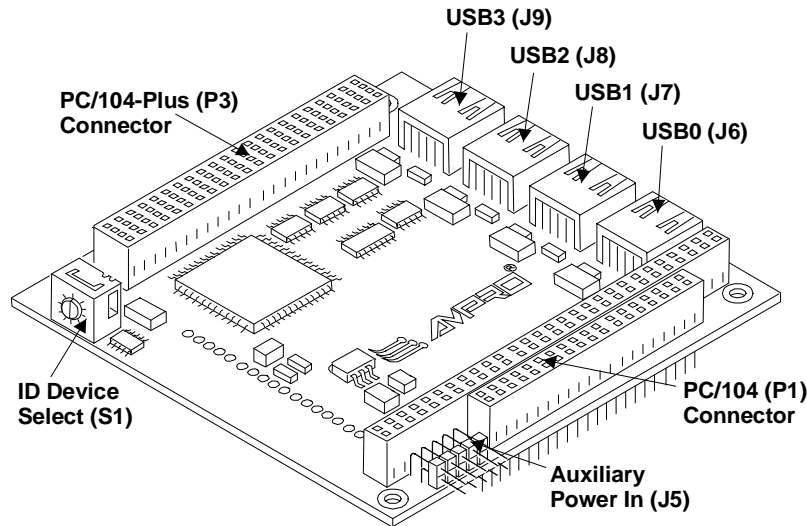

Figure 2-3. MiniModule USB2

13) Install the spacers on the target board	<ul style="list-style-type: none"> <li>Install the threaded spacers onto the target board at the four corners of the MiniModule board. See Figures 2-4 and 2-5.</li> </ul>
14) Gently align the connectors and pins	<ul style="list-style-type: none"> <li>Place the PC/104 pins over the connector beneath and align the pins to the connector.</li> <li>Gently insert the PC/104 pins into the connector, ensuring each pin goes into the respective hole in the connector.</li> </ul> <p>If you have difficulty matching pins, do not try to force the pins in. Use a small flat blade screwdriver to help position the pins over the holes.</p>
15) Slowly insert the MiniModule board into the connectors	<ul style="list-style-type: none"> <li>Once the pins are aligned with the proper holes, slowly insert the MiniModule board into the connectors.</li> <li>Ensure the pins go all the way into the connector and are seated on the target board.</li> </ul> <p>There should just be enough space between the target board and the MiniModule USB2 board to insert the threaded spacers and secure.</p>

16) If necessary, install any additional MiniModule boards	If there are any additional expansion boards, install the boards now, before powering up the target system.
17) Set the Device ID in the stack, if known.	The Device ID Select switch (S1) is used to configure the PCI position of MiniModule USB2 in the board stack. Refer to Figure 2-3, Table 2-1, and Table 3-3 in Chapter 3, <i>Product Overview</i> for more information.

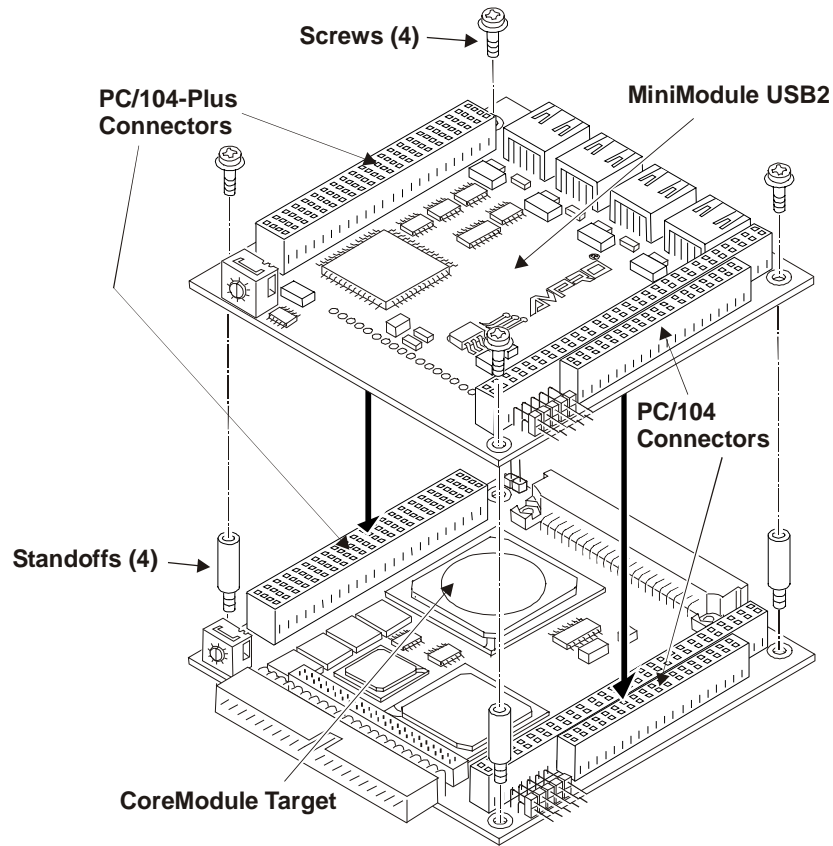

Figure 2-4. Installing MiniModule USB2 on CoreModule Target

Table 2-1. Device ID Select Position Switch (S1)

Switch Position	MiniModule Position in PCI Stack
0 (or 4)	1
1 (or 5)	2
2 (or 6)	3
3 (or 7)	4

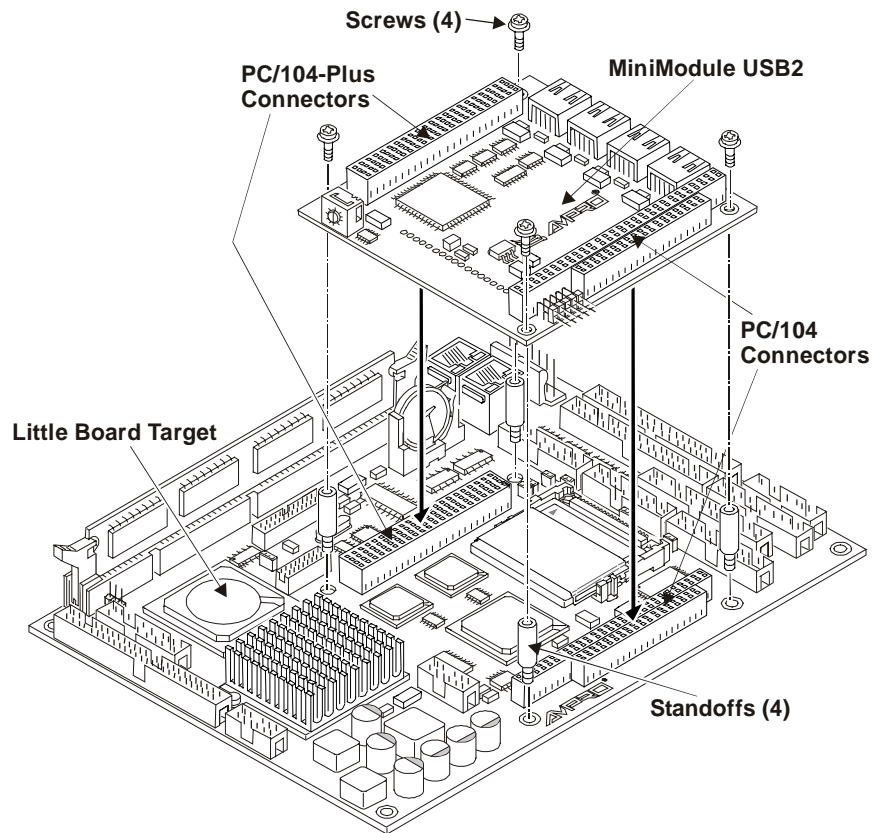

Figure 2-5. Installing MiniModule USB2 on Little Board Target

### Applying Power to the Target System

18) Check/Set the Power Supply Input Voltage	<ul style="list-style-type: none"> <li>• If the power supply uses auto-ranging operation at 50/60Hz, skip this step.</li> <li>• Check the input voltage switch on the power supply located on the rear of the supply just below the power connector. The input voltage switch typically has two positions: 115 or 230 volts – 115 volts is default position.</li> </ul>
19) Power up the target system.	<ul style="list-style-type: none"> <li>• Plug the CRT monitor's power cord into an AC outlet and turn on the monitor.</li> <li>• Plug the AT power supply's power cord into the AC outlet.</li> <li>• Turn the AT power supply's power switch to On before continuing.</li> </ul>
20) Verify the target system powers-up satisfactorily.	<ul style="list-style-type: none"> <li>• Refer to the target system's QuickStart Guide for further instructions about completing the boot process.</li> </ul>

The MiniModule USB2 board does not require any further setup, except the connection of the USB 2.0 cables to the USB ports on the board.

- The MiniModule USB2 supports hot insertion/removal of the USB 2.0 cables.
- The MiniModule USB2 supports the Plug and Play option with Plug 'n Play operating systems.
- The MiniModule USB2 is backward compatible (USB v1.1) to older operating systems.
- The BIOS of the target system is not affected by the MiniModule USB2 board.

For more specific technical information about the MiniModule USB2, refer to the reference chapters.

## Accessing Drivers and Documentation

To check for updates, access drivers for supported operating systems that do not support Plug 'n Play operation, or get a PDF copy of this manual, refer to the following steps.

1. Run the MiniModule Documentation & Support Software CD-ROM (Doc & SW CD-ROM) to access the CD's contents.

This includes the MiniModule USB2 documentation, release notes, and any OS drivers that are not part of the target system OS or on the OS manufacturer's diskette(s) or CD-ROM.

The Doc & SW CD-ROM will operate on any Windows PC, allowing you to view, download, or print the contents of the CD-ROM. This includes the MiniModule USB2 *QuickStart Guide and Reference Manual*, Release Notes, and any software drivers.

**NOTE**

You must have an Internet browser to view the main menu and make selections (examples: Microsoft Internet Explorer 4.x, or greater, Netscape Navigator version 4.x, or greater, or the equivalent on a PC). Software download links are provided for Adobe Acrobat Reader version 4.x or greater to view the manuals and documents.

The Doc & SW CD-ROM should auto-start, but if it does not, go to the root level of the CD-ROM and locate the index.htm by:

- a. Selecting Run from the Start menu in any Windows PC.
- b. Browsing the contents of the CD-ROM until you find the index.htm at the root level.
- c. Selecting this file and pressing OK to start the CD-ROM.

The CD-ROM starts and opens the main menu of the CD-ROM.

2. Select the MiniModule USB2 from the main menu.

This menu has links to the documentation, including the manual and release notes, and links for any for available software drivers for the supported operating systems.

3. Install any special OS drivers not found as part of the target system OS or on the OS manufacturer's diskette(s) or CD-ROM.

Refer to the directory under the MiniModule USB2 menu item on the Doc & SW CD-ROM for instructions on installing the special drivers for the desired OS.

If the desired drivers can not be found, contact Ampro through the Virtual Technician on the web site with a request for the driver(s), or use the *Check for Latest Updates* link on the Doc & SW CD-ROM to check for the latest drivers on the web site.



# Chapter 3 Product Overview

This introduction presents general information about the PC/104 architecture and the MiniModule USB2 (USB 2.0) expansion board. After reading this chapter you should understand:

- PC/104 and PC/104-Plus Concept
- MiniModule USB2 Architecture and Features
- Major components and Connectors
- Specifications

## PC/104-Plus Architecture

The PC/104-Plus architecture affords a great deal of flexibility in system design. You can build a simple system using only a CPU/Controller, such as an Ampro Little Board or CoreModule SBC, which provides the processor, memory, and standard input/output device connections (keyboard, mouse, serial, parallel, floppy drive, and IDE drives). To expand the I/O capability of a simple system, simply add self-stacking PC/104 and PC/104-Plus expansion boards, such as Ampro's MiniModules, to provide additional capabilities, such as:

- Additional serial and Ethernet ports
- USB or IEEE 1394 (FireWire)
- PC card interfaces
- Sound cards

PC/104-Plus expansion boards can be stacked with the CPU Board avoiding the need for card cages and backplanes. The PC/104-Plus expansion boards can be mounted directly to the PC/104 and PC/104-Plus bus connectors of the CPU Boards. PC/104-Plus compliant boards can be stacked with an inter-board spacing of ~0.66 inches so that a 3-board system fits in a 3.6 inch by 3.8 inch by 2.4 inch space. See Figure 3-1.

One or more PC/104 and PC/104-Plus boards can be installed on the CPU board's expansion connectors. When installed on an Ampro CoreModule or Little Board, the expansion board fits within the CoreModule or Little Board outline dimensions. Most MiniModule products have stackthrough connectors compatible with the PC/104 and PC/104-Plus Version 2.1 specification. Each additional board increases the thickness of the package by 15mm (0.66"). See Figure 3-2.

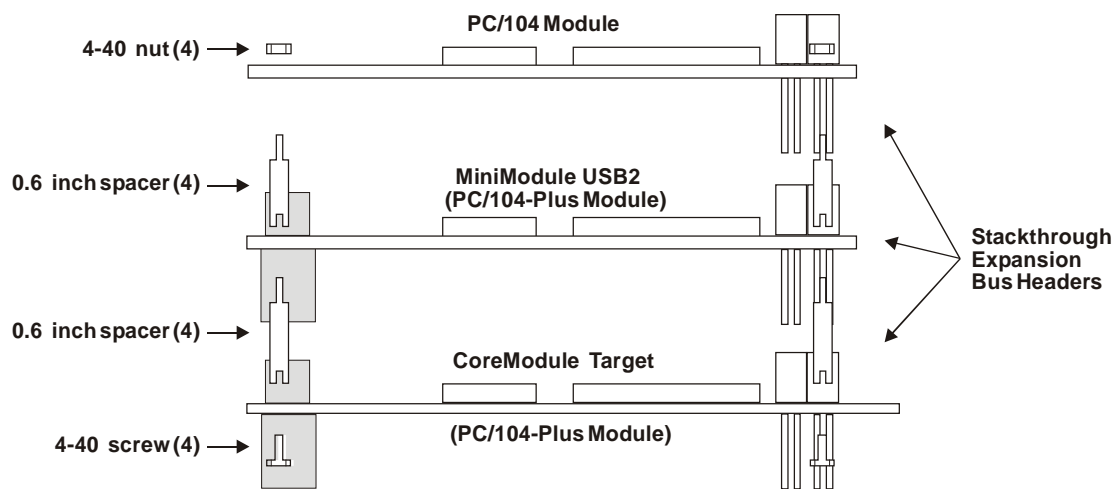

Figure 3-1. CoreModule Target Stackthrough Connections

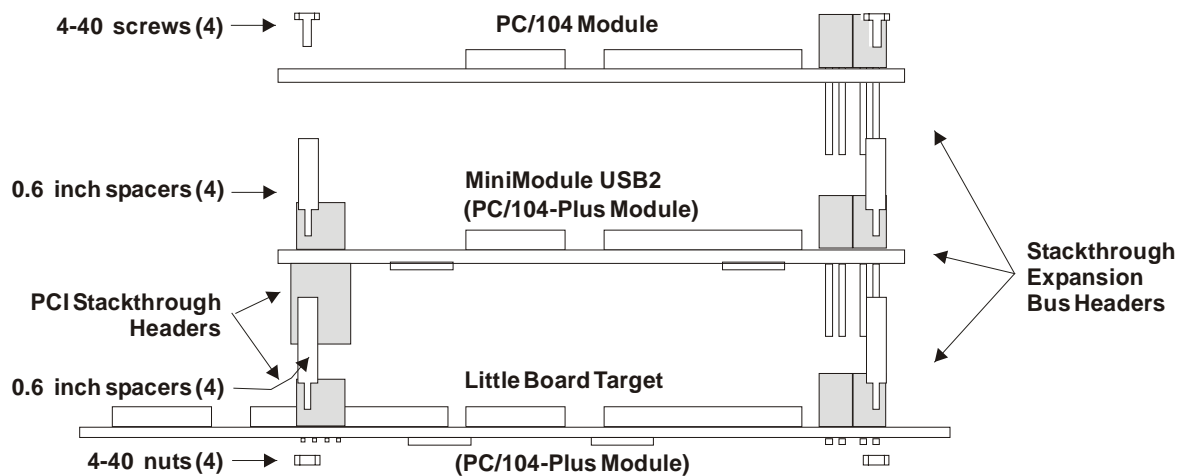

Figure 3-2. Little Board Target Stackthrough Connections

## Product Description

The MiniModule USB2 is a PC/104-Plus compliant communication board providing four USB 2.0 interface connectors. The size and expansion bus connectors of the MiniModule USB2 conform to the PC/104-Plus standard and can be installed directly on Ampro's Little Board and CoreModule single board computer systems supporting the PC/104-Plus expansion bus. The MiniModule USB2 provides a 32-bit PCI host interface. The MiniModule USB2 only requires a single +5V power source, usually provided over the PC/104-Plus bus.

The MiniModule USB2 is particularly well suited to either embedded or portable applications. Its flexibility makes system design quick and easy. It can be stacked with other Ampro MiniModules or other PC/104-Plus compliant expansion boards.

## Module Features

- Platform
  - ◆ Supports the PC/104-Plus platforms
  - ◆ Conforms to the PC/104-Plus form factor (96x90x23 mm)
  - ◆ Number of MiniModule USB2 supported (PCI bus limitations)
- Controller (NEC  $\mu$ PD720101)
  - ◆ USB 2.0
    - Supports low speed (1.5Mbps) signaling (legacy)
    - Supports full speed (12Mbps) signaling (legacy)
    - Supports high speed (480Mbps) signaling
  - ◆ Implements December 21, 2000 version of the USB 2.0 Specification
  - ◆ Supports OHCI Version 1.1 interface (USB v1.1 and Intel Universal HCI v1.1)
  - ◆ Supports EHCI Version 1.0 interface
  - ◆ Supports 4-wire 4k-bit Serial EEPROM (SEEP)
  - ◆ Supports and implements PCI bus specification version 2.2 interface (32-bit, 33MHz, PCI bus master and target)
  - ◆ Supports USB host, root hub and four downstream USB ports
- Device Interfaces

- ◆ Supports USB 1.1 and USB 2.0 devices transparently
- ◆ Supports hot insertion or removal of any USB 2.0 cable
- ◆ Supports four USB 2.0 ports
- ◆ Offers both standard USB connectors and optional transition headers for each port
- ◆ Requires no BIOS changes in target system
- Software
  - ◆ Supports Plug and Play operation with target board Plug-n-Play operating systems
  - ◆ Supports drivers for:
    - Windows 98se / Me /2000 / XP / XP Embedded
    - Windows CE.NET (4.1)
    - TimeSys Linux
- Power Supply voltage
  - ◆ +5.0VDC +/-5% @ 0.212 Amps (Typically provided through PC/104-Plus connector)

## Block Diagram

Figure 3-3 provides a functional block diagram of the MiniModule USB2 board.

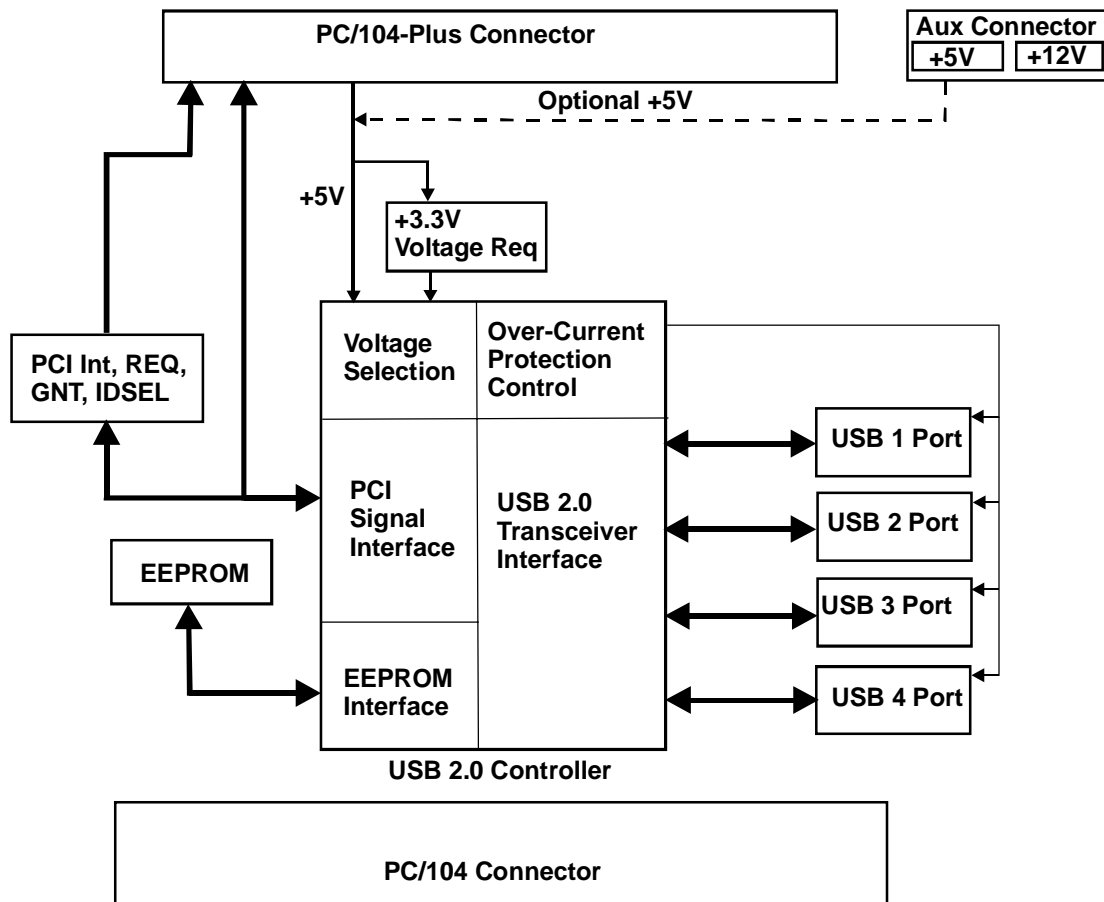

Figure 3-3. MiniModule USB2 Block Diagram

### Major Integrated Circuits (ICs)

Table 3-1 lists the major integrated circuits (chips), including a brief description of each, on the MiniModule USB2 and Figure 3-4 shows the location of the major chips.

**Table 3-1. Major Integrated Circuit Descriptions and Function**

Chip Type	Mfg.	Model	Description	Function
USB Controller/ Transceiver (U1)	NEC	μPD720101	USB host controller, PCI interface and transceiver	USB controller

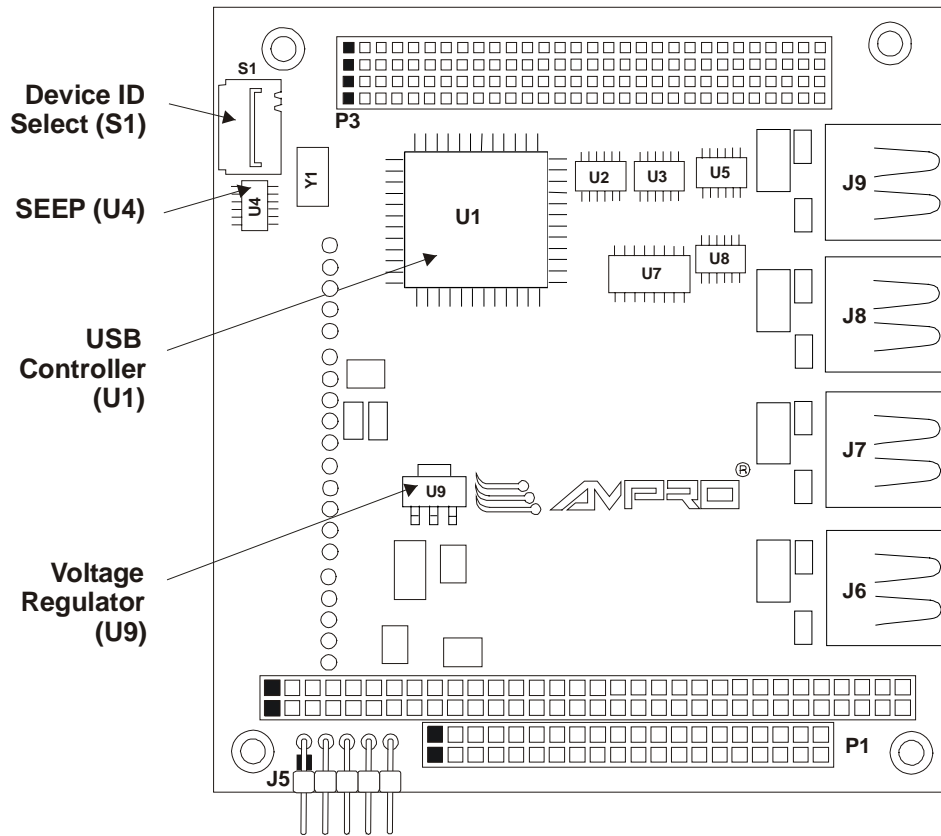

**Figure 3-4. MiniModule USB2 (Top View)**

## Connectors and Switches

### Connector Definitions

Table 3-2 describes the connectors shown in Figures 3-4 to 3-6.

**Table 3-2. Connector Descriptions**

Jack/Plug #	Board Access	Description
P1A/P1B & P1C/P1D – PC/104 Bus	Top/Bottom	104-pin connector used for the PC/104 bus (ISA bus) (PC/104 connector is used as pass-through connector)
P3 – PC/104-Plus	Top/Bottom	120-pin connector for PC/104-Plus
J5 – Auxiliary Power	Top	10-pin connector used for the Auxiliary Power
J6 – USB 0	Top	6-pin connector used for the USB 2.0 interface
J7 – USB 1	Top	6-pin connector used for the USB 2.0 interface
J8 – USB 2	Top	6-pin connector used for the USB 2.0 interface
J9 – USB 3	Top	6-pin connector used for the USB 2.0 interface

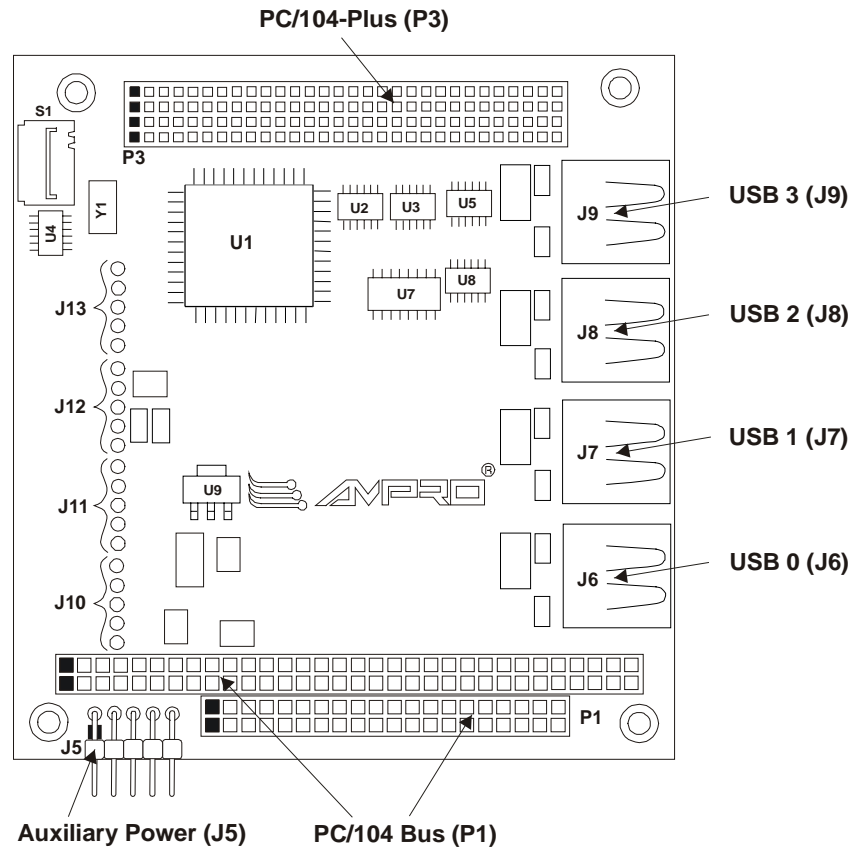

**Figure 3-5. Connector Locations (Top View)**

**NOTE**

Pin 1 is shown as black square pin in all connectors in all illustrations. Connector positions J10, J11, J12, and J13 are available for optional right angle headers used with transition cables. Contact Ampro for more information.

## Selection Switch

The 10-position rotary switch (S1) is used to configure the PCI position of the MiniModule USB2 board in the board stack. Every PCI card must have a unique address. Table 3-3 provides the switch settings shown in Figure 3-6.

**Table 3-3. Device ID Selection Switch (S1)**

Switch Position	Module Slot	REQ#	GNT#	CLK	INT#0	INT#1	INT#2	INT#3
0 (or 4)	1	REQ0#	GNT0#	CLK0	INTA#	INTB#	INTC#	INTD#
1 (or 5)	2	REQ1#	GNT1#	CLK1	INTB#	INTC#	INTD#	INTA#
2 (or 6)	3	REQ2#	GNT2#	CLK2	INTC#	INTD#	INTA#	INTB#
3 (or 7)	4	REQ3#	GNT3#	CLK3	INTD#	INTA#	INTB#	INTC#

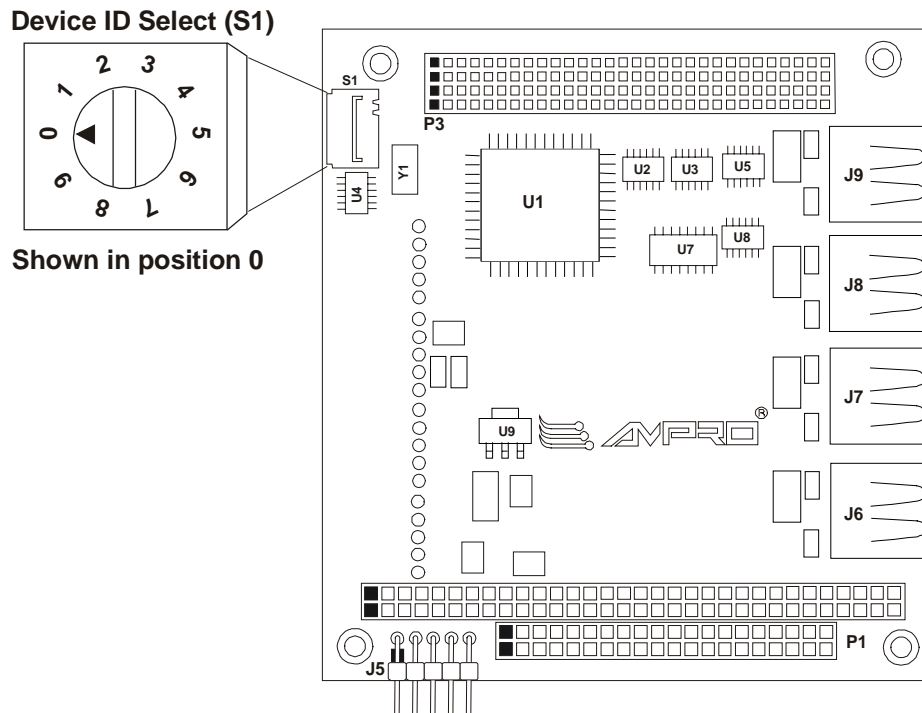

**Figure 3-6. Device ID Selection Switch (Top View)**

# Specifications

## Physical Specifications

Table 3-4 gives the physical dimensions of the board and Figure 3-7 gives the mounting dimensions.

**Table 3-4. Weight and Footprint Dimensions**

Item	Dimension
Weight	0.0907 kg. (0.2 lbs.)
Height (overall, connector)	23.49 mm (0.925 inches)
Width	90.2 mm (3.6 inches)
Length	95.9 mm (3.8 inches )

## Mechanical Specifications

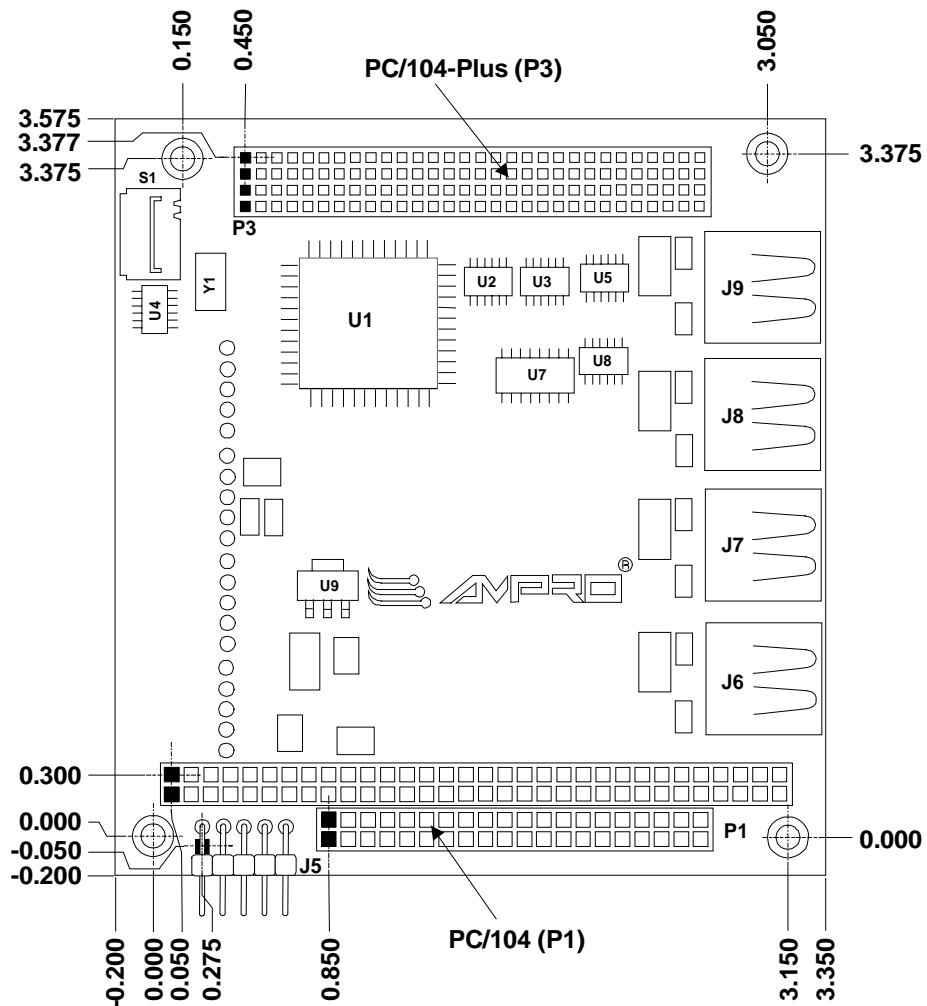

**Figure 3-7. Mechanical Dimensions (Top View)**

**NOTE** All dimensions are given in inches. Pin 1 is shown as a black square pin in all connectors in all illustrations.

## Power Specifications

Table 3-5 gives the power requirements.

**Table 3-5. Power Supply Requirements**

Parameter	Characteristics
Input Type	Regulated DC voltages
Input Power Requirements	+5VDC +/- 5% @ 0.212Amps
Operating Power	1.06 W Continuous

## Environmental Specifications

Table 3-6 provides the most efficient operating and storage condition ranges required for this board.

**Table 3-6. Environmental Requirements**

Parameter	Conditions
<b>Temperature</b>	
Operating	+0° to +70° C (32° to 158° F)
Extended (Optional)	-40° to +85° C (-40° F to +185° F)
Storage	-55° to +85° C (-67° F to +185° F)
<b>Humidity</b>	
Operating	20% to 80% relative humidity, non-condensing
Non-operating	5% to 95% relative humidity, non-condensing

## Thermal/Cooling Requirements

The USB Host controller (U1) does not require a heatsink.

# Chapter 4 Hardware Description

## Overview

This chapter discusses the chips and connectors of the board features in the following order:

- PC/104-Plus (P3)
- PC/104 (P1A, B, C, D)
- USB 2.0 connectors (J6, J7, J8, J9)
- Auxiliary Power Connector (J5)

<b>NOTE</b>	Ampro Computers, Inc. only supports the features/options tested and listed in this manual. The integrated circuits (chips) used in the MiniModule USB2 may provide more features or options than are listed for the MiniModule USB2, but some of these chip features/options are not supported on the board and will not function as specified in the chip documentation.
-------------	---

## PC/104-Plus Interface (P3)

The PC/104-Plus uses a 120-pin (30x4) header interface. This interface header will carry all of the appropriate PCI signals operating at clock speeds up to 33MHz. This interface header is stackable and is located on the top and bottom of the board.

Table 4-1 provides the signals and descriptions for each of the PC/104-Plus bus pin-outs.

**Table 4-1. PC/104-Plus Pin/Signal Descriptions (P3)**

Pin #	Signal	Input/ Output	Description
1 (A1)	GND/ (Key)		Key - Digital Ground
2 (A2)	VI/O		+5 volts $\pm 5\%$ power supply
3 (A3)	AD05	T/S	PCI Address and Data Bus Line 5 – There are 32 signal lines (address and data) and the signals on these lines are multiplexed. A bus transaction consists of an address followed by one or more data cycles.
4 (A4)	C/BE0*	T/S	PCI Bus Command/Byte Enable 0 – This signal line is one of four signal lines. These signal lines are multiplexed, so that during the address cycle, the command is defined and during the data cycle, the byte enable is defined.
5 (A5)	GND		Digital Ground
6 (A6)	AD11	T/S	PCI Address and Data Bus Line 11 – Refer to Pin 3 for more information.
7 (A7)	AD14	T/S	PCI Address and Data Bus Line 14 – Refer to Pin 3 for more information.
8 (A8)	+3.3V		+3.3 volts $\pm 5\%$ power supply
9 (A9)	SERR*	O/D	System Error – This signal is for reporting address parity errors.

Pin #	Signal	Input/ Output	Description
10 (A10)	GND		Digital Ground
11 (A11)	STOP*	S/T/S	Stop – This signal indicates the current selected device is requesting the master to stop the current transaction
12 (A12)	+3.3V		+3.3 volts $\pm 5\%$ power supply
13 (A13)	FRAME*	S/T/S	PCI bus Frame access – This signal is driven by the current master to indicate the transaction start and will remain active until the final data cycle
14 (A14)	GND		Digital Ground
15 (A15)	AD18	T/S	PCI Address and Data Bus Line 18 – Refer to Pin 3 for more information.
16 (A16)	AD21	T/S	PCI Address and Data Bus Line 21 – Refer to Pin 3 for more information.
17 (A17)	+3.3V		+3.3 volts $\pm 5\%$ power supply
18 (A18)	IDSEL0	In	Initialization Device Select 0 – This signal line is one of four signal lines. These signals are used as the chip-select signals during configuration
19 (A19)	AD24	T/S	PCI Address and Data Bus Line 24 – Refer to Pin 3 for more information.
20 (A20)	GND		Digital Ground
21 (A21)	AD29	T/S	PCI Address and Data Bus Line 29 – Refer to Pin 3 for more information.
22 (A22)	+5V		+5 volts $\pm 5\%$ power supply
23 (A23)	REQ0*	T/S	Bus Request 0 – This signal line is one of three signal lines. These signals indicate the device desires use of the bus to the arbitrator.
24 (A24)	GND		Digital Ground
25 (A25)	GNT1*	T/S	Grant 1 – This signal line is one of three signal lines. These signal lines indicate access has been granted to the requesting device (PCI Masters).
26 (A26)	+5V		+5 volts $\pm 5\%$ power supply
27 (A27)	CLK2	In	PCI clock 2 – This signal line is one of four signal lines. These clock signals provide the timing outputs for four external PCI devices and the timing for all transactions on the PCI bus
28 (A28)	GND		Digital Ground
29 (A29)	+12V		+12 volts $\pm 5\%$ power supply
30 (A30)	NC		Not connected - Reserved
31 (B1)	NC		Not connected - Reserved
32 (B2)	AD02	T/S	PCI Address and Data Bus Line 2 – Refer to Pin 3 for more information.
33 (B3)	GND		Digital Ground
34 (B4)	AD07	T/S	PCI Address and Data Bus Line 7 – Refer to Pin 3 for more information.
35 (B5)	AD09	T/S	PCI Address and Data Bus Line 9 – Refer to Pin 3 for more information.

Pin #	Signal	Input/ Output	Description
36 (B6)	VI/O		+5 volts $\pm 5\%$ power supply
37 (B7)	AD13	T/S	PCI Address and Data Bus Lines 13 – Refer to Pin 3 for more information.
38 (B8)	C/BE1*	T/S	PCI Bus Command/Byte Enable 1 – Refer to Pin 4 for more information.
39 (B9)	GND		Digital Ground
40 (B10)	PERR*		Parity Error – This signal is for reporting data parity errors.
41 (B11)	+3.3V		+3.3 volts $\pm 5\%$ power supply
42 (B12)	TRDY*	S/T/S	Target Ready – This signal indicates the selected device's ability to complete the current cycle of transaction. Both IRDY* and TRDY* must be asserted to terminate a data cycle.
43 (B13)	GND		Digital Ground
44 (B14)	AD16	T/S	PCI Address and Data Bus Line 16 – Refer to Pin 3 for more information.
45 (B15)	+3.3V		+3.3 volts $\pm 5\%$ power supply
46 (B16)	AD20	T/S	PCI Address and Data Bus Lines 20 – Refer to Pin 3 for more information.
47 (B17)	AD23	T/S	PCI Address and Data Bus Line 23 – Refer to Pin 3 for more information.
48 (B18)	GND		Digital Ground
49 (B19)	C/BE3*	T/S	PCI Bus Command/Byte Enable 3 – Refer to Pin 4 for more information.
50 (B20)	AD26	T/S	PCI Address and Data Bus Line 26 – Refer to Pin 3 for more information.
51 (B21)	+5V		+5 volts $\pm 5\%$ power supply
52 (B22)	AD30	T/S	PCI Address and Data Bus Line 30 – Refer to Pin 3 for more information.
53 (B23)	GND		Digital Ground
54 (B24)	REQ2*	T/S	Bus Request – This signal indicates this device desires use of the bus to the arbitrator.
55 (B25)	VI/O		+5 volts $\pm 5\%$ power supply
56 (B26)	CLK0	In	PCI clock 0– Refer to Pin 27 for more information
57 (B27)	+5V		+5 volts $\pm 5\%$ power supply
58 (B28)	INTD*	O/D	Interrupt D – This signal is used to request interrupts only for multi-function devices.
59 (B29)	INTA*	O/D	Interrupt A – This signal is used to request an interrupt.
60 (B30)	NC		Not connected - Reserved
61 (C1)	+5		+5 volts $\pm 5\%$ power supply
62 (C2)	AD01	T/S	PCI Address and Data Bus Line 1 – Refer to Pin 3 for more information.
63 (C3)	AD04	T/S	PCI Address and Data Bus Lines 4 – Refer to Pin 3 for more information.

Pin #	Signal	Input/ Output	Description
64 (C4)	GND		Digital Ground
65 (C5)	AD08	T/S	PCI Address and Data Bus Line 8 – Refer to Pin 3 for more information.
66 (C6)	AD10	T/S	PCI Address and Data Bus Line 10 – Refer to Pin 3 for more information.
67 (C7)	GND		Digital Ground
68 (C8)	AD15	T/S	PCI Address and Data Bus Line 15 – Refer to Pin 3 for more information.
69 (C9)	SB0*	NC	Snoop Backoff – Not connected
70 (C10)	+3.3V		+3.3 volts $\pm 5\%$ power supply
71 (C11)	LOCK*	S/T/S	Lock – This signal indicates an operation that may require multiple transactions to complete
72 (C12)	GND		Digital Ground
73 (C13)	IRDY*	S/T/S	Initiator Ready – This signal indicates the master's ability to complete the current data cycle of the transaction
74 (C14)	+3.3V		+3.3 volts $\pm 5\%$ power supply
75 (C15)	AD17	T/S	PCI Address and Data Bus Line 17 – Refer to Pin 3 for more information.
76 (C16)	GND		Digital Ground
77 (C17)	AD22	T/S	PCI Address and Data Bus Line 22 – Refer to Pin 3 for more information.
78 (C18)	IDSEL1		Initialization Device Select 1 – Refer to Pin 18 for more information
79 (C19)	VI/O	NC	(+5V) Not connected
80 (C20)	AD25	T/S	PCI Address and Data Bus Line 25 – Refer to Pin 3 for more information.
81 (C21)	AD28	T/S	PCI Address and Data Bus Line 28 – Refer to Pin 3 for more information.
82 (C22)	GND		Digital Ground
83 (C23)	REQ1*	T/S	Bus Request 1 – Refer to Pin 23 for more information.
84 (C24)	+5V		+5 volts $\pm 5\%$ power supply
85 (C25)	GNT2*	T/S	Grant 2 – Refer to Pin 25 for more information
86 (C26)	GND		Digital Ground
87 (C27)	CLK3	In	PCI clock 3 – Refer to Pin 27 for more information
88 (C28)	+5V		+5 volts $\pm 5\%$ power supply
89 (C29)	INTB*	O/D	Interrupt B – This signal is used to request interrupts only for multi-function devices.
90 (C30)	PME*		Power Management Event – This signal is used for power management events
91 (D1)	AD00	T/S	PCI Address and Data Bus Line 0 – Refer to Pin 3 for more information.
92 (D2)	+5V		+5 volts $\pm 5\%$ power supply

Pin #	Signal	Input/ Output	Description
93 (D3)	AD03	T/S	PCI Address and Data Bus Lines 3 – Refer to Pin 3 for more information.
94 (D4)	AD06	T/S	PCI Address and Data Bus Lines 6 – Refer to Pin 3 for more information.
95 (D5)	GND		Digital Ground
96 (D6)	M66EN		66MHz device enable – Provides path for 66MHz when used
97 (D7)	AD12	T/S	PCI Address and Data Bus Line 12 – Refer to Pin 3 for more information.
98 (D8)	+3.3V		+3.3 volts $\pm$ 5% power supply
99 (D9)	PAR	T/S	PCI bus Parity bit – This signal is the even parity bit on AD[31:0] and C/BE[3:0]*
100 (D10)	SDONE	NC	Snoop Done – Not connected
101 (D11)	GND		Digital Ground
102 (D12)	DEVSEL*	S/T/S	Device Select – This signal is driven by the target device when its address is decoded.
103 (D13)	+3.3V		+3.3 volts $\pm$ 5% power supply
104 (D14)	C/BE2*		PCI Bus Command/Byte Enable 2 – Refer to Pin 4 for more information.
105 (D15)	GND		Digital Ground
106 (D16)	AD19	T/S	PCI Address and Data Bus Line 19 – Refer to Pin 3 for more information.
107 (D17)	+3.3V		+3.3 volts $\pm$ 5% power supply
108 (D18)	IDSEL2		Initialization Device Select 2 – Refer to Pin 18 for more information.
109 (D19)	IDSEL3		Initialization Device Select 3 – Refer to Pin 18 for more information.
110 (D20)	GND		Digital Ground
111 (D21)	AD27	T/S	PCI Address and Data Bus Line 27 – Refer to Pin 3 for more information.
112 (D22)	AD31	T/S	PCI Address and Data Bus Line 31 – Refer to Pin 3 for more information.
113 (D23)	VI/O		+5 volts $\pm$ 5% power supply
114 (D24)	GNT0*	T/S	Grant 0 – Refer to Pin 25 for more information.
115 (D25)	GND		Digital Ground
116 (D26)	CLK1	In	PCI clock 1 – Refer to Pin 27 for more information
117 (D27)	GND		Digital Ground
118 (D28)	RST*	In	PCI bus reset – This signal is an output signal to reset the entire PCI Bus. This signal will be asserted during system reset
119 (D29)	INTC*	O/D	Interrupt C – This signal is used to request interrupts only for multi-function devices.
120 (D30)	GND		Digital Ground

**Notes:** The shaded area denotes power or ground. The signals marked with \* = Negative true logic.

The Input/Output signals in this table refer to the input/output signals listed in the *PCI Local Bus Manual*, Revision 2.2, Chapter 2, paragraph 2.1, Signal definitions. The following terms or acronyms are used in this table:

- In – Input is standard input only signal
- Out – Totem Pole output is a standard active driver
- T/S – Tri-State is a bi-directional input output pin
- S/TS – Sustained Tri-State is an active low tri-state signal driven by one and only one agent at a time
- O/D – Open Drain allows multiple devices to share as a wire-OR.

## PC/104 Bus Interface (P1A, B, C, D)

The PC/104 Bus uses a 104-pin 100mm header interface. This interface header will carry all of the appropriate PC/104 signals operating at clock speeds up to 8MHz to other boards in the stack. The interface header is located on the both the top and bottom of the board.

<b>NOTE</b>	The PC/104 Bus connector is only used as a pass through connector to other boards in the stack and has no connections to the MiniModule USB2 expansion board except the +5V and ground connections.
-------------	---

**Table 4-2. PC/104 Bus Interface Pin/Signal Descriptions (P1A)**

Pin #	Signal	Description (P1 Row A)
1 (A1)	NC (IOCHCHK*)	Not Connected (bus NMI input)
2 (A2)	NC (SD7)	Not Connected (Data bit 7)
3 (A3)	NC (SD6)	Not Connected (Data bit 6)
4 (A4)	NC (SD5)	Not Connected (Data bit 5)
5 (A5)	NC (SD4)	Not Connected (Data bit 4)
6 (A6)	NC (SD3)	Not Connected (Data bit 3)
7 (A7)	NC (SD2)	Not Connected (Data bit 2)
8 (A8)	NC (SD1)	Not Connected (Data bit 1)
9 (A9)	NC (SD0)	Not Connected (Data bit 0)
10 (A10)	NC (IOCHRDY)	Not Connected (Processor Ready Ctrl)
11 (A11)	NC (AEN)	Not Connected (Address Enable )
12 (A12)	NC (SA19)	Not Connected (Address bit 19)
13 (A13)	NC (SA18)	Not Connected (Address bit 18)
14 (A14)	NC (SA17)	Not Connected (Address bit 17)
15 (A15)	NC (SA16)	Not Connected (Address bit 16)
16 (A16)	NC (SA15)	Not Connected (Address bit 15)
17 (A17)	NC (SA14)	Not Connected (Address bit 14)
18 (A18)	NC (SA13)	Not Connected (Address bit 13)
19 (A19)	NC (SA12)	Not Connected (Address bit 12)
20 (A20)	NC (SA11)	Not Connected (Address bit 11)
21 (A21)	NC (SA10)	Not Connected (Address bit 10)
22 (A22)	NC (SA9)	Not Connected (Address bit 9)

Pin #	Signal	Description (P1 Row A)
23 (A23)	NC (SA8)	Not Connected (Address bit 8)
24 (A24)	NC (SA7)	Not Connected (Address bit 7)
25 (A25)	NC (SA6)	Not Connected (Address bit 6)
26 (A26)	NC (SA5)	Not Connected (Address bit 5)
27 (A27)	NC (SA4)	Not Connected (Address bit 4)
28 (A28)	NC (SA3)	Not Connected (Address bit 3)
29 (A29)	NC (SA2)	Not Connected (Address bit 2)
30 (A30)	NC (SA1)	Not Connected (Address bit 1)
31 (A31)	NC (SA0)	Not Connected (Address bit 0)
32 (A32)	GND	Ground

**Notes:** The shaded area denotes power or ground. The signals marked with \* = Negative true logic.

**Table 4-3. PC/104 Bus Interface Pin/Signal Descriptions (P1B)**

Pin #	Signal	Description (P1 Row B)
33 (B1)	GND	Ground
34 (B2)	NC (RESETDRV)	Not Connected (System reset signal)
35 (B3)	+5V	+5V power
36 (B4)	NC (IRQ9)	Not Connected (Interrupt request 9)
37 (B5)	NC (-5V)	Not Connected (-5V)
38 (B6)	NC (DRQ2)	Not Connected (DMA request 2)
39 (B7)	NC (-12V)	Not Connected (-12V)
40 (B8)	NC (ENDXFR*)	Not Connected (Zero wait state)
41 (B9)	+12V	+12V power
42 (B10)	GND	Key pin
43 (B11)	NC (SMEMW*)	Not Connected (System Memory Write (lower 1MB))
44 (B12)	NC (SMEMR*)	Not Connected (System Memory Read (lower 1MB))
45 (B13)	NC (IOW*)	Not Connected (I/O Write)
46 (B14)	NC (IOR*)	Not Connected (I/O Read)
47 (B15)	NC (DACK3*)	Not Connected (DMA Acknowledge 3)
48 (B16)	NC (DRQ3)	Not Connected (DMA Request 3)
49 (B17)	NC (DACK1*)	Not Connected (DMA Acknowledge 1)
50 (B18)	NC (DRQ1)	Not Connected (DMA Request 1)
51 (B19)	NC (REFRESH*)	Not Connected (Memory Refresh)
52 (B20)	NC (SYSCLK)	Not Connected (Sys Clock)
53 (B21)	NC (IRQ7)	Not Connected (Interrupt Request 7)
54 (B22)	NC (IRQ6)	Not Connected (Interrupt Request 6)
55 (B23)	NC (IRQ5)	Not Connected (Interrupt Request 5)
56 (B24)	NC (IRQ4)	Not Connected (Interrupt Request 4)
57 (B25)	NC (IRQ3)	Not Connected (Interrupt Request 3)
58 (B26)	NC (DACK2*)	Not Connected (DMA Acknowledge 2)

Pin #	Signal	Description (P1 Row B)
59 (B27)	NC (TC)	Not Connected (DMA Terminal Count)
60 (B28)	NC (BALE)	Not Connected (Address latch enable)
61 (B29)	+5V	+5V power
62 (B30)	NC (OSC)	Not Connected (14.3MHz clock)
63 (B31)	GND	Ground
64 (B32)	GND	Ground

**Notes:** The shaded area denotes power or ground. The signals marked with \* = Negative true logic.

**Table 4-4. PC/104 Bus Interface Pin/Signal Descriptions (P1C)**

Pin #	Signal	Description (P1 Row C)
1 (C0)	GND	Ground
2 (C1)	NC (SBHE*)	Not Connected (System Bus High Enable)
3 (C2)	NC (LA23)	Not Connected (Address bit 23)
4 (C3)	NC (LA22)	Not Connected (Address bit 22)
5 (C4)	NC (LA21)	Not Connected (Address bit 21)
6 (C5)	NC (LA20)	Not Connected (Address bit 20)
7 (C6)	NC (LA19)	Not Connected (Address bit 19)
8 (C7)	NC (LA18)	Not Connected (Address bit 18)
9 (C8)	NC (LA17)	Not Connected (Address bit 17)
10 (C9)	NC (MEMR*)	Not Connected (Memory Read)
11 (C10)	NC (MEMW*)	Not Connected (Memory Write)
12 (C11)	NC (SD8)	Not Connected (Data Bit 8)
13 (C12)	NC (SD9)	Not Connected (Data Bit 9)
14 (C13)	NC (SD10)	Not Connected (Data Bit 10)
15 (C14)	NC (SD11)	Not Connected (Data Bit 11)
16 (C15)	NC (SD12)	Not Connected (Data Bit 12)
17 (C16)	NC (SD13)	Not Connected (Data Bit 13)
18 (C17)	NC (SD14)	Not Connected (Data Bit 14)
19 (C18)	NC (SD15)	Not Connected (Data Bit 15)
20 (C19)	GND	Ground - Key Pin

**Notes:** The shaded area denotes power or ground. The signals marked with \* = Negative true logic.

**Table 4-5. PC/104 Bus Interface Pin/Signal Descriptions (P1D)**

Pin #	Signal	Description (P1 Row D)
21 (D0)	GND	Ground
22 (D1)	NC (MEMCS16*)	Not Connected (16-bit Memory Access)
23 (D2)	NC (IOCS16*)	Not Connected (16-bit I/O Access)
24 (D3)	NC (IRQ10)	Not Connected (Interrupt Request 10)
25 (D4)	NC (IRQ11)	Not Connected (Interrupt Request 11)
26 (D5)	NC (IRQ12)	Not Connected (Interrupt Request 12)
27 (D6)	NC (IRQ15)	Not Connected (Interrupt Request 15)

Pin #	Signal	Description (P1 Row D)
28 (D7)	NC (IRQ14)	Not Connected (Interrupt Request 14)
29 (D8)	NC (DACK0*)	Not Connected (DMA Acknowledge 0)
30 (D9)	NC (DRQ0)	Not Connected (DMA Request 0)
31 (D10)	NC (DACK5*)	Not Connected (DMA Acknowledge 5)
32 (D11)	NC (DRQ5)	Not Connected (DMA Request 5)
33 (D12)	NC (DACK6*)	Not Connected (DMA Acknowledge 6)
34 (D13)	NC (DRQ6)	Not Connected (DMA Request 6)
35 (D14)	NC (DACK7*)	Not Connected (DMA Acknowledge 7)
36 (D15)	NC (DRQ7)	Not Connected (DMA Request 7)
37 (D16)	+5V	+5V Power
38 (D17)	NC (MASTER*)	Not Connected (Bus Master Assert)
39 (D18)	GND	Ground
40 (D19)	GND	Ground

**Notes:** The shaded area denotes power or ground. The signals marked with \* = Negative true logic.

## USB Interface (J6, J7, J8, J9)

**Table 4-6. USB Port 0 Interface Pin/Signal Descriptions (J6)**

Pin #	Signal	Description
1	VBus	Bus Power (+5 Volts +/- 5%)
2	P1-	Data I/O -
3	P1+	Data I/O +
4	GND	Digital Ground
5	SHLD1	GND
6	SHLD2	GND

**Note:** The shaded area denotes power or ground.

**Table 4-7. USB Port 1 Interface Pin/Signal Descriptions (J7)**

Pin #	Signal	Description
1	VBus	Bus Power (+5 Volts +/- 5%)
2	P2-	Data I/O -
3	P2+	Data I/O +
4	GND	Digital Ground
5	SHLD1	GND
6	SHLD2	GND

**Note:** The shaded area denotes power or ground.

**Table 4-8. USB Port 2 Interface Pin/Signal Descriptions (J8)**

Pin #	Signal	Description
1	VBus	Bus Power (+5 Volts +/- 5%)
2	P3-	Data I/O -
3	P3+	Data I/O +
4	GND	Digital Ground
5	SHLD1	GND
6	SHLD2	GND

**Note:** The shaded area denotes power or ground.

**Table 4-9. USB Port 3 Interface Pin/Signal Descriptions (J9)**

Pin #	Signal	Description
1	VBus	Bus Power (+5 Volts +/- 5%)
2	P4-	Data I/O -
3	P4+	Data I/O +
4	GND	Digital Ground
5	SHLD1	GND
6	SHLD2	GND

**Notes:** The shaded area denotes power or ground.

## Auxiliary Power Interface (J5)

The MiniModule USB2 draws its power from the PC/104-Plus connector and only requires +5 volt input power. The +5V is used to generate +3.3V on board.

- +5VDC +/- 5% @ 0.212 Amps

If additional +5V or +12V power is required to power a USB device, it can be provided by the auxiliary power connector (J5). The auxiliary power connector uses a 10-pin header with 0.100" spacing. The auxiliary power connector (J5) supplies the voltages listed in Table 4-10 directly to the board for external use:

Table 4-10 gives the signals for power supply pin outs and Table 4-11 provides the pin arrangement.

**Table 4-10. Auxiliary Power Interface Pins/Signals (J5)**

Pin #	Signal	Description
1	GND	Ground
2	+5	+5 Volts +/- 5%
3	Key	Key pin
4	+12V	+12 Volts +/- 5%
5	GND	Ground
6	NC	Not connected
7	GND	Ground
8	+5	+5 Volts +/- 5%
9	GND	Ground
10	+5	+5 Volts +/- 5%

**Note:** The shaded area denotes power or ground.

**Table 4-11. Auxiliary Power Pin Arrangement (J5)**

Pin #	Signal	Pin #	Signal
1	GND	2	+5V
3	KEY	4	+12V
5	GND	6	NC
7	GND	8	+5V
9	GND	10	+5V

**Note:** The shaded area denotes power or ground.



# Appendix A Technical Support

---

## Contacting Support

Ampro Computers, Inc. provides a number of methods for contacting Technical Support listed in the Table A-1 below. Requests for support through the Virtual Technician are given the highest priority, and usually will be addressed within one working day.

- Ampro Virtual Technician – This is a comprehensive support center designed to meet all your technical needs. This service is free and available 24 hours a day through the Ampro web site at <http://ampro.custhelp.com>. This includes a searchable database of Frequently Asked Questions, which will help you with the common information requested by most customers. This is a good source of information to look at first for your technical solutions. However, you must sign in to access this service.

Personal Assistance – You may also request personal assistance by going to the "Ask a Question" area in the Virtual Technician. Requests can be submitted 24 hours a day, 7 days a week. You will receive immediate confirmation that your request has been entered. Once you have submitted your request you can go to the "My Stuff" area and log in to check status, update your request, and access other features.

- Embedded Design Resource Center – This service is also free and available 24 hours a day at the Ampro web site at <http://www.ampro.com>. However, you must sign in to access this service.

The Embedded Design Resource Center was created as a resource for embedded system developers to share Ampro's knowledge, insight, and expertise gained from years of experience. This page contains links to White Papers, Specifications, and additional technical information.

**Table A-1. USA Technical Support Contact Information**

Method	Contact Information
Virtual Technician	<a href="http://ampro.custhelp.com">http://ampro.custhelp.com</a>
Web Site	<a href="http://www.ampro.com">http://www.ampro.com</a>
E-mail	<a href="mailto:support@ampro.com">support@ampro.com</a>
Standard Mail	Ampro Computers, Incorporated 5215 Hellyer Avenue San Jose, CA 95138-1007, USA

## Getting Updates

This feature is provided for you on the MiniModule Doc & SW (Documentation & Support Software) CD-ROM and is a hot link to Ampro's Web site. You can access the latest updates by clicking on *Check for Latest Updates* in the CD-ROM's main menu. The link on the CD-ROM takes you to the Ampro web site where the search and compare engine on the web site compares your current CD-ROM to the latest files available on the Ampro web site.

Once you have made a selection of desired material to update, the search and compare engine generates a list of the current manuals or software updates not on your CD-ROM and displays this list on the screen for you to view. Once the list is displayed you can select the desired updates or new files from the list you want to download to your PC. You can then printout the updates or files, save it to disk, or store it on a new CD-ROM. This list includes documentation and driver updates. However, you will have to login in to the Ampro web site to access this information.



# Index

---

Ampro Products	
CoreModule Family .....	3
EnCore Family .....	3
Little Board Family .....	3
MiniModule™ 1394 .....	3
MiniModule™ ESB .....	3
MiniModule™ PCC II .....	2
MiniModule™ PCC III .....	3
Ampro Virtual Technician .....	33
CD-ROM	
MiniModule Doc & SW .....	2
MiniModule Documentation and Support Software (Doc & SW) .....	2
CD-ROM access .....	11
chip specifications .....	2
chip web sites .....	2
contacting Technical Support .....	33
dimensions .....	19
Embedded Design Resource Center .....	33
environmental specifications .....	20
getting updates .....	33
heatsink	
requirements .....	20
input and output codes	
table notes .....	26
integrated circuit web sites .....	2
major integrated circuits .....	16
MiniModule USB2	
auxiliary power connector .....	31
block diagram .....	15
CD-ROM access .....	11
Device interfaces .....	14
drivers .....	11
environmental requirements .....	20
heatsink requirements .....	20
integrated circuits .....	16
pass through connector .....	26
PC/104-Plus connector .....	21
PC/104-Plus power .....	15
PCI stack position .....	9
power requirements .....	20
product description .....	14
product features .....	14
QuickStart Kit .....	2
QuickStart requirements .....	5
selector switch .....	18
specifications .....	19
stack position .....	18
supported software .....	15
target system .....	7
USB controller .....	14
MiniModule Documentation and Support Software CD-ROM .....	2
MiniModule Doc & SW CD-ROM .....	2
pass through connector	
PC/104 bus .....	26
PC/104 and PC/104-Plus Concept .....	13
PC/104 bus	
pass through connector .....	26
PC/104 only modules	
not supported .....	1
PCI Bus	
33 MHz .....	21
PCI stack position	
selector switch .....	9, 18
power requirements .....	20
QuickStart Guide	
Chapter 2 .....	1
QuickStart Kit	
CD-ROM .....	2
contents .....	2
MiniModule USB2 .....	2
Reference Manual	
Chapters 1, 3, 4 .....	1
reference material	
specifications .....	1, 2
selector switch	
stack position .....	18
site preparation	
environmental considerations .....	20
specifications	
integrated circuits .....	2
MiniModule USB2 .....	19
reference material .....	1, 2
stack position	
selector switch .....	18
table notes	
input and output codes .....	26
target board .....	1
target system	
CoreModule boards .....	7
Little Board single board computers .....	7
Technical Support .....	33
updates	
drivers .....	33
weight .....	19





