



CoreModule™ 420
PC/104 Single Board Computer
Reference Manual

P/N 5001808A Revision A

Notice Page

NOTICE

No part of this document may be reproduced, transmitted, transcribed, stored in a retrieval system, or translated into any language or computer language, in any form or by any means, electronic, mechanical, magnetic, optical, chemical, manual, or otherwise, without the prior written permission of Ampro Computers, Incorporated.

DISCLAIMER

Ampro Computers, Incorporated makes no representations or warranties with respect to the contents of this manual or of the associated Ampro products, and specifically disclaims any implied warranties of merchantability or fitness for any particular purpose. Ampro shall under no circumstances be liable for incidental or consequential damages or related expenses resulting from the use of this product, even if it has been notified of the possibility of such damages. Ampro reserves the right to revise this publication from time to time without obligation to notify any person of such revisions. If errors are found, please contact Ampro at the address listed below on the Notice page of this document.

TRADEMARKS

Ampro and the Ampro logo are registered trademarks, and CoreModule, EnCore, Little Board, LittleBoard, MightyBoard, MiniModule, ReadyBoard, ReadyBox, ReadyPanel, and ReadySystem are trademarks of Ampro Computers, Inc. All other marks are the property of their respective companies.

REVISION HISTORY

Revision	Reason for Change	Date
A, A	Initial Release	Jun/06

Ampro Computers, Incorporated
5215 Hellyer Avenue
San Jose, CA 95138-1007
Tel: 408 360-0200
Fax: 408 360-0222
www.ampro.com

© Copyright 2006, Ampro Computers, Incorporated

Audience Assumptions

This reference manual is for the person who designs computer related equipment, including but not limited to hardware and software design and implementation of the same. Ampro Computers, Inc. assumes you are qualified in designing and implementing your hardware designs and its related software into your prototype computer equipment.

Contents

Chapter 1 About This Manual.....	1
Purpose of this Manual	1
Reference Material	1
Related Ampro Products	2
Chapter 2 Product Overview	5
PC/104 Architecture	5
Product Description	6
Module Features	6
Block Diagram	9
Major Integrated Circuits (ICs)	10
Connectors, Jumpers, and LEDs	11
Connector Definitions	11
Jumper Definitions	12
LED Definitions	12
Specifications	14
Physical Specifications	14
Mechanical Specifications.....	14
Power Specifications.....	15
Environmental Specifications.....	15
Thermal/Cooling Requirements	15
Chapter 3 Hardware	17
Overview	17
CPU (U14)	18
Memory	18
SDRAM Memory (U7, U8, U9, U10)	18
Flash Memory (U6)	18
Bytewise Socket (U5)	18
Memory Map	18
Interrupt Channel Assignments.....	20
I/O Address Map	20
PC/104 Bus Interface (P1A,B,C,D)	22
IDE Interface (J6)	27
Compact Flash Socket Interface (J12).....	29
Floppy/Parallel Interface (J4)	31
Floppy Disk Drive Port	31
Parallel Port.....	31
Serial Interface (J3, J9, J13, J14)	33
USB Interface (J10).....	35
Utility Interface (J5)	36
Keyboard.....	36
Mouse	36
Battery	36
Reset Switch	36
Speaker	36
Ethernet Interface (J2)	37
Video (LCD/CRT) Interface (J11).....	38

Contents

Miscellaneous	41
Real Time Clock (RTC)	41
User GPIO Interface	41
Oops! Jumper (BIOS Recovery).....	42
Serial Console	42
Watchdog Timer	43
Power Interface (J7)	44
Chapter 4 BIOS Setup	45
Introduction	45
Accessing BIOS Setup (VGA Display)	45
Accessing BIOS Setup (Serial Console)	46
Main BIOS Setup Menu	47
BIOS Configuration Screen	48
Drive Configurations and Boot Options.....	48
User Interface Options.....	50
Memory Control Options.....	50
Power Management and Advanced User Options	51
Video and On Board Controller Options.....	52
PCI, Plug n' Play, and Interrupt/DMA Assignments	52
Splash Screen Customization.....	55
Splash Screen Image Requirements.....	55
Converting the Splash Screen File.....	55
On-Board Flash Access and Use	57
Flash Programming Requirements.....	57
Building the Example.....	57
Example Assumptions.....	58
Installing the Example Application.....	58
Flash Boot API.....	58
Appendix A Technical Support	59
Appendix B Connector Part Numbers	61
Index	63

List of Figures

Figure 2-1. Stacking PC/104 Modules with the CoreModule 420.....	5
Figure 2-2. Block Diagram.....	9
Figure 2-3. Component Locations (Top View).....	10
Figure 2-4. Connector Locations (Top View).....	11
Figure 2-5. Jumper and LED Locations (Top View)	13
Figure 2-6. Connector Location (Bottom View)	13
Figure 2-7. Mechanical Dimensions (Top View).....	14
Figure 3-1. RS-485 Serial Port Implementation.....	33
Figure 3-2. Oops! Jumper.....	42
Figure 3-3. Hot Cable Jumper	42
Figure 4-1. BIOS Setup Opening Screen	47
Figure 4-2. BIOS Configuration Screen.....	48

List of Tables

Table 2-1. Major Integrated Circuit (Chips) Descriptions and Function 10

Table 2-2. Connector Descriptions..... 11

Table 2-3. Jumper Settings 12

Table 2-4. Ethernet Port (J2) LED Indicators..... 12

Table 2-5. Weight and Footprint Dimensions..... 14

Table 2-6. Power Supply Requirements 15

Table 2-7. Environmental Requirements 15

Table 3-1. Memory Map 18

Table 3-2. Interrupt Channel Assignments 20

Table 3-3. DMA Map 20

Table 3-4. I/O Address Map 20

Table 3-5. PC/104 Bus Interface Pin/Signal Descriptions (P1A) 22

Table 3-6. PC/104 Bus Interface Pin/Signal Descriptions (P1B) 23

Table 3-7. PC/104 Bus Interface Pin/Signal Descriptions (P1C) 24

Table 3-8. PC/104 Bus Interface Pin/Signal Descriptions (P1D) 25

Table 3-9. IDE Interface Pin/Signal Descriptions (J6)..... 27

Table 3-10. Compact Flash Socket Interface Pin/Signal Descriptions (J12) 29

Table 3-11. Floppy/Parallel Interface Pin/Signal Descriptions (J4)..... 31

Table 3-12. Serial Ports 1 & 2 Interface Pin/Signal Descriptions (J3, J9)..... 34

Table 3-13. Serial Ports 3 & 4 Interface Pin/Signal Descriptions (J13, J14)..... 34

Table 3-14. USB Interface Pin/Signal Designations (J10) 35

Table 3-15. Utility Interface Pin/Signal Descriptions (J5)..... 36

Table 3-16. Ethernet Interface Pin/Signal Descriptions (J2)..... 37

Table 3-17. Video Interface Pin/Signal Descriptions (J11) 39

Table 3-18. User GPIO Interface Pin/Signal Descriptions (J8)..... 41

Table 3-19. Power Interface Pin/Signals (J7) 44

Table 3-20. Power Interface Pin Arrangement (J7) 44

Table 4-1. BIOS Setup Menus 46

Table A-1. Technical Support Contact Information 59

Table B-1. Connector and Manufacture's Part Numbers 61

Chapter 1 About This Manual

Purpose of this Manual

This manual is for designers of systems based on the CoreModule™ 420 PC/104 single board computer (SBC) module. This manual contains information that permits designers to create an embedded system based on specific design requirements.

Information provided in this reference manual includes:

- CoreModule 420 SBC Specifications
- Environmental requirements
- Major chips and features implemented
- CoreModule 420 SBC connector/pin numbers and definition
- BIOS Setup information

Information not provided in this reference manual includes:

- Detailed chip specifications
- Internal component operation
- Internal registers or signal operations
- Bus or signal timing for industry standard busses and signals

Reference Material

The following list of reference materials may be helpful for you to complete your custom design successfully. Most of this reference material is also available on the Ampro web site in the Embedded Design Resource Center. The Embedded Design Resource Center was created for embedded system developers to share Ampro's knowledge, insight, and expertise gained from years of experience.

Specifications

- PC/104 Specifications Revision 2.5, November 2003

For latest revision of the PC/104 specifications, contact the PC/104 Consortium, at:

Web site: <http://www.pc104.org>

Major Integrated Circuit (Chip) Specifications

The following chip specifications are used in the CoreModule 420 processor module:

- STMicroelectronics and the chip, STPC® Atlas, used for the embedded CPU

Web site: <http://us.st.com/stonline/books/pdf/docs/7341.pdf>

- Standard Microsystems Corp and the chip, FDC37B782, used for the Super I/O controller

Web site: <http://www.smsc.com/main/catalog/fdc37b78x.html>

- Intel Corporation and the chip, 82559ER, used for the Ethernet controller

Web site: <http://www.intel.com/design/network/datashts/714682.htm> (71468206.pdf)

NOTE

If you are unable to locate the datasheets using the links provided, go to the manufacturer's web site where you can perform a search using the chip datasheet number or name listed, including the extension, (htm for web page, pdf for files name, etc.

Related Ampro Products

The following items are directly related to successfully using the Ampro product you have just purchased or plan to purchase. Ampro highly recommends that you purchase and utilize a CoreModule 420 QuickStart Kit simultaneously with the design of your product.

CoreModule 420 Support Products

- CoreModule 420 QuickStart Kit (QSK)

The CoreModule 420 QuickStart Kit includes the CoreModule 420 CPU, a complete cable kit, documentation, and drivers for Ampro supported operating systems and unique devices used on the board.

- CoreModule 420 Documentation and Support Software CD-ROM

The CoreModule 420 Documentation and Support Software (Doc & SW) CD-ROM is provided with the CoreModule 420 QuickStart Kit. The CD-ROM includes all of the CoreModule documentation, including this Reference Manual and the CoreModule 420 QuickStart Guide in PDF format, release notes, software utilities, and drivers.

Other CoreModule Products

- CoreModule™ 410 – This PC/104 embedded CPU is a state-of-the-art, high-integration x86-based computer using STMicroelectronics 133 MHz STPC Elite processor, which provides a complete embedded PC solution with most of the standard peripheral interfaces. In addition to the standard CoreModule features (PC/104 form factor, PC/104 bus, +5 volt power, etc.), it includes 16 MB soldered SDRAM memory, byte-wide socket supporting DiskOnChip 2000 devices and a GPIO interface for customer usage. The CoreModule 410 also offers a watchdog timer, serial console, BIOS extensions for OEM boot customization, and Advanced Power Management.
- CoreModule™ 600 – This PC/104-Plus embedded single board computer (SBC) is a compact, rugged, high integration, ultra low power 400 MHz ULV Celeron® processor with 256 kB of internal cache, and all of the standard peripheral interfaces. In addition to the standard CoreModule features (PC/104 form factor, PC/104-Plus, +5 volt power, etc.), the CoreModule 600 includes 10/100BaseT Ethernet, AGP 4X equivalent video with 32 MB video memory for CRT, TFT and standard LCD flat panels, USB ports, RS-232C/RS-485 serial ports, and an onboard compact flash socket, which supports up to 1 GB or more of memory. The CoreModule 600 also supports a watchdog timer, serial console, battery-less boot, BIOS extensions for OEM boot customization, some power management features and up to 256 MB of SDRAM memory.
- CoreModule™ 800 – This compact, rugged, high integration PCI-104 embedded single board computer (SBC) provides the Intel® 855GME chipset to support the Intel 800 MHz Ultra Low Voltage (ULV) Celeron M processor with 0 kB Level 2 internal cache, and all of the standard peripheral interfaces. In addition to the standard CoreModule features (PCI-104 form factor, +5 volt power, etc.), the CoreModule 800 includes a Gigabit Ethernet port, 128-bit video with 64 MB video memory for CRT, TFT and standard LCD flat panels, USB 2.0 ports (2), RS-232/RS-485 serial ports (2), and an onboard SODIMM socket, which supports up to 1 GB DDR memory. The CoreModule 800 also supports a watchdog timer, serial console (remote access), battery-less boot, and ACPI power management features.

Other Ampro Products

- **ETX Family** – These high-performance, compact, rugged Computer-on-Module (COM) solutions use various x86 processors from Celeron to Pentium® M CPUs in an ETX Revision 2.7 form factor to plug into your custom baseboard. Each ETX module provides standard peripherals, including dual Ultra/DMA 33/66/100 IDE, floppy drive interface, PCI bus, ISA bus, serial, parallel, PS/2 keyboard and mouse interfaces, 10/100BaseT Ethernet, USB ports, Video, and AC'97 audio. A 50% thicker PCB, Ampro embedded BIOS extensions, such as watchdog timer, battery-free boot, a customizable splash screen, BIOS recovery, serial console, and optional – 40°C to +85°C operation are available to meet your rugged application requirements.
- **LittleBoard™ Family** – These high-performance, highly integrated single board computers use the EBX form factor (5.75"x8.00"), and are available with Pentium M, Celeron M, Pentium III, or Celeron processors. The EBX-compliant LittleBoard single board computers offer functions equivalent to a complete laptop or desktop PC system, plus several expansion cards. Built-in extras to meet the critical requirements of embedded applications include onboard solid state disk capability, watchdog timer, smart power monitor, and other embedded-PC BIOS enhancements.
- **MightyBoard™ Family** – These low-cost, high-performance single-board computers (SBC) use the Mini-ITX form factor (6.75" x 6.75") and are available with Intel Celeron M and Pentium M processors. MightyBoard products offer the equivalent functions of a complete laptop or desktop PC system, including DDR memory, high performance graphics, USB 2.0, Gigabit Ethernet, plus standard PCI expansion capability in one card slot. Ampro includes configuration control and embedded BIOS extensions such as watchdog timer, battery-free boot, a customizable splash screen, BIOS recovery, and serial console.
- **MiniModule™ Family** – This line of peripheral interface modules, compliant with PC/104, PC/104-Plus, and/or PCI-104 form factor (3.6"x3.8") and standards, can be used with Ampro's CoreModule, LittleBoard, and ReadyBoard single board computers (SBCs) to expand the I/O configuration of embedded systems. Ampro's highly reliable MiniModule products add value to existing designs by adding I/O ports, such as IEEE 1394 (FireWire), or by adding support for legacy boards, such as a PCI to ISA bridge adapter board.
- **ReadyBoard™ Family** – These low-cost, high-performance single-board computers (SBC) use the EPIC form factor (4.5"x6.5") and are available with the Intel Celeron, Pentium III, Pentium M, and Celeron M processors. ReadyBoard products offer functions equivalent to a complete laptop or desktop PC system, plus several expansion cards, with PC-style connectors. Ampro includes configuration control and embedded BIOS extension such as watchdog timer, battery-free boot, a customizable splash screen, BIOS recovery, and serial console.
- **ReadyPanel™ Family** – This is a series of high performance, low cost, turnkey systems incorporating an LCD and a touch screen for a Human Machine Interface solution. All ReadyPanels come with one of Ampro's versatile ReadyBoard models in a variety of touch screen sizes pre-loaded with one of Ampro's supported operating systems (Windows® CE, etc.). The ReadyPanel includes a compact flash socket, a specific size of SODIMM memory, an Ethernet port, two serial ports, two USB ports standard, with two additional USB ports on selected models. The current models are driven by an integrated 4-wire resistive 6.5" touch screen that displays up to 262k colors. The ReadyPanel is powered by +5V (for board) and +12V DC (for panel) power input.

- ReadySystem™ Family – The ReadySystem family is a series of high performance, low cost turnkey systems that come with a ReadyBoard product installed into a particular size ReadyBox enclosure with a specific size SODIMM, and a 2 ½" hard disk drive pre-loaded with one of Ampro's supported operating systems (Linux®, etc.). The ReadySystem provides all of the ReadyBoard's standard PC style connectors accessible on the front I/O panel, including three audio connectors, and a slot for a compact flash card. Depending on the enclosure, you may add PC style connectors for two additional serial ports (4 total), two additional USB ports (4 total), and one parallel port connector. You may also install up to two PCI-104 or PC/104-Plus expansion boards into the ReadySystem ATX and 2U enclosures. A ReadySystem comes pre-tested and ready for application loading to provide customers with the fastest possible deployment of their embedded applications. Refer to the specific ReadySystem Users Guide on the web site, or the ReadyBoard product Documentation and Support Software (Doc & SW) CD-ROM for more information.

This introduction presents general information about the PC/104 architecture and the CoreModule 420 single board computer (SBC). After reading this chapter you should understand:

- PC/104 Concept
- CoreModule 420 architecture
- CoreModule 420 features
- Major components
- Connectors
- Specifications

PC/104 Architecture

The PC/104 architecture affords a great deal of flexibility in system design. You can build a simple system using only a CoreModule single board computer (SBC), with input/output devices connected to its serial or parallel ports, and a solid state disk on chip in the bytewise socket or a compact flash card in the compact flash socket. To expand a simple CoreModule system, simply add self-stacking Ampro MiniModules or 3rd party PC/104 expansion boards to provide additional capabilities, such as:

- Additional I/O ports (such as IEEE 1394 (FireWire))
- Analog or digital I/O interfaces

PC/104 expansion modules can be stacked with the CoreModule 420 avoiding the need for card cages and backplanes. The PC/104 expansion modules can be mounted directly to the PC/104 bus connector of the CoreModule 420. PC/104-compliant modules can be stacked with an inter-board spacing of ~0.66" (16.7 mm) so that a 3-module system fits in a 3.6" x 3.8" x 2.4" space. See Figure 2-1.

One or more MiniModule products or other PC/104 modules can be installed on the CoreModule expansion connectors. When installed on the PC/104 headers, the expansion modules fit within the CoreModule outline dimensions. Most MiniModule products have stack through connectors compatible with the PC/104 Version 2.5 specification. Several modules can be stacked on the CoreModule headers. Each additional module increases the thickness of the package by 0.60" (15 mm). See Figure 2-1.

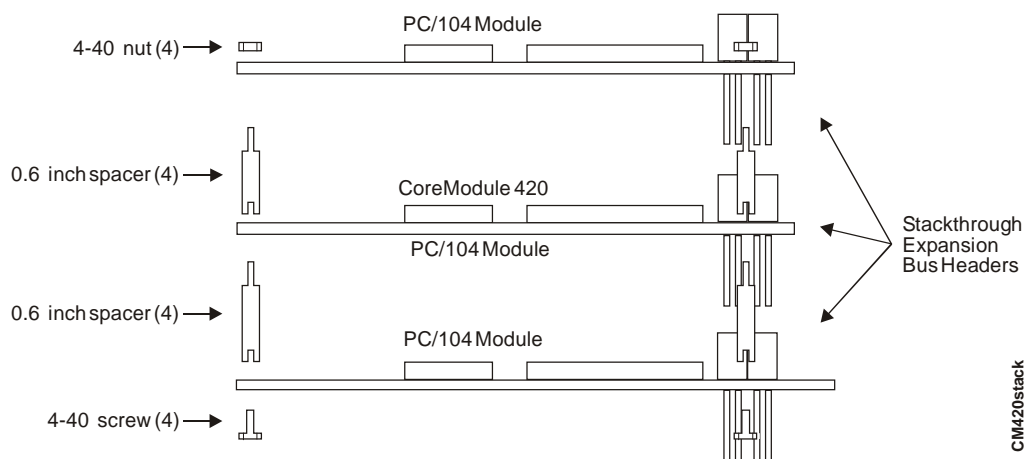

Figure 2-1. Stacking PC/104 Modules with the CoreModule 420

Product Description

The CoreModule 420 SBC is an exceptionally high integration, high-performance, 486-based PC compatible system in the PC/104 form factor. This rugged and high quality single board system contains all the component subsystems of a PC/AT motherboard plus the equivalent of several PC/AT expansion boards.

In addition, the CoreModule 420 SBC includes a comprehensive set of system extensions and enhancements that are specifically designed for embedded systems. These enhancements ensure fail-safe embedded system operation, such as, a watchdog timer. It is designed to meet the size, power consumption, temperature range, quality, and reliability demands of embedded applications. The CoreModule 420 requires a single +5V power source.

The CoreModule 420 SBC is particularly well suited to either embedded or portable applications. Its flexibility makes system design quick and easy. It can be stacked with Ampro MiniModules or other PC/104-compliant expansion board, or it can be used as the computing engine in a fully customized application.

Module Features

- CPU
 - ◆ Provides 133 MHz x86 based STPC ATLAS microprocessor
 - ◆ Fully supports PC compatible architecture
 - ◆ Provides 8 kB Unified Instruction and Data Cache
 - ◆ Provides Parallel Processing Integrated Floating Point Unit
 - ◆ Provides Low Power and System Management Modes
- Memory
 - ◆ Provides 64 MB standard SDRAM (soldered on the board)
 - ◆ Supports 100 MHz Clock Speed
 - ◆ Provides 32-pin bytewise memory socket
 - Supports a DiskOnChip[®] device
 - ◆ 1 MB Flash memory
 - Stores system BIOS
 - Stores system Setup parameters and manufacturing information
 - Supports battery-free boot capability
 - 768 kB available for OEM use
- PC/104 Bus Interface
 - ◆ Supports clock speeds up to 8.25 MHz
- IDE Interface
 - ◆ Supports two enhanced IDE devices
 - ◆ Provides Fast ATA-capable interface for high-speed PIO modes (PIO modes 0 to 4)
 - ◆ Supports ATAPI and DVD peripherals
 - ◆ Supports IDE native and ATA compatibility modes

- Compact Flash Socket
 - ◆ Provides compact flash socket (Type I or II)
 - ◆ Supports IDE compact flash cards
 - ◆ Attached to Secondary IDE bus
- Floppy Disk Controller
 - ◆ Provides shared floppy/parallel port connector
 - ◆ Supports two floppy drives
 - ◆ Supports all standard PC/AT formats: 360 kB, 1.2 MB, 720 kB, 1.44 MB, 2.88 MB
- Serial Ports
 - ◆ Provides four buffered RS-232 serial ports with full handshaking and modem capability
 - ◆ Provides 16550 (or 16540-equivalent) UARTs, each with a built-in 16-byte FIFO buffer
 - ◆ Supports RS-232 or RS-485 operation on ports 1 and 2
 - ◆ Supports programmable word length, stop bits, and parity
 - ◆ Supports 16-bit programmable baud-rate generator and a interrupt generator
- Parallel Port
 - ◆ Provides shared parallel/floppy port connector
 - ◆ Supports standard printer port
 - ◆ Supports IEEE standard 1284 protocols, including EPP, ECP modes
 - ◆ Provides bidirectional data lines
 - ◆ Supports 16 byte FIFO for ECP mode
- Ethernet Controller
 - ◆ Intel 82559ER Controller chip
 - ◆ Supports IEEE 802.3 10BaseT/100BaseT compatible physical layer
 - ◆ Supports Auto-negotiation for speed, duplex mode, and flow control
 - ◆ Supports full duplex or half-duplex mode
 - Full-duplex mode supports transmit and receive frames simultaneously
 - Supports IEEE 802.3x Flow control in full duplex mode
 - Half-duplex mode supports enhanced proprietary collision reduction mode
- Utility Interface
 - ◆ Keyboard and PS/2 Mouse Interface
 - ◆ Supports external battery for Real Time Clock operation
 - ◆ Supports standard external 8 Ω speaker interface
 - ◆ Supports external reset switch
- USB Ports
 - ◆ Provides one root USB hub
 - ◆ Provides one USB port
 - ◆ Supports USB v1.1 and Universal OHCI v1.1

- Video (LCD/CRT) Display

Enhanced 2D graphics controller

- ◆ Supports BitBLT implementation for all 256 raster operations for Windows® support
- ◆ Supports all BLT transparency modes
 - Bitmap transparency
 - Pattern transparency
 - Source transparency
 - Destination transparency
- ◆ Supports 8, 16, 24, and 32-bit pixel depths
- ◆ Supports hardware clipping
- ◆ Supports fast line draw engine with anti-aliasing
- ◆ Supports fast triangle fill engine
- ◆ Supports 4-bit alpha blend font for anti-aliased text display
- ◆ Supports 64-bit wide pipelined architecture operating at 100 MHz
- ◆ Supports complete double buffered registers for pipelined operation
- ◆ Provides video memory up to 4 MB – selected in BIOS Setup

CRT Interface

- ◆ VGA Controller with 135 MHz triple RAMDACs for 1280 x 1024 x 75 Hz display
- ◆ Supports 24-bit pixel depth
- ◆ Interlaced or non-interlaced output

LCD/TFT Interface

- ◆ Supports VESA Flat Panel Display interface FPDI-1B
- ◆ Supports programmable panel size up to 1024x768 pixel display resolution
- ◆ Supports VGA and SVGA active matrix TFT flat panels
- ◆ Support internal CRT controller for display mode settings
- ◆ Supports 9-, 12-, and 18-bit interface (1 Pixel/Clock)
- ◆ Supports 2x9-bit interface (2 Pixels/Clock)
- ◆ Supports programmable image position
- ◆ Supports 3.3V or 5V LCD panels; jumper selectable
- ◆ Provides Video BIOS customization tools

- Miscellaneous

- ◆ Provides Real Time Clock and CMOS RAM, with support for battery-free operation
- ◆ Provides General Purpose I/O (GPIO) interface
- ◆ Supports Oops! Jumper (BIOS Recovery)
- ◆ Supports Serial Console (Console Redirection)
- ◆ Supports customizable Splash Screen
- ◆ Supports Watchdog Timer (WDT)

Block Diagram

Figure 2-2 shows the functional components of the module.

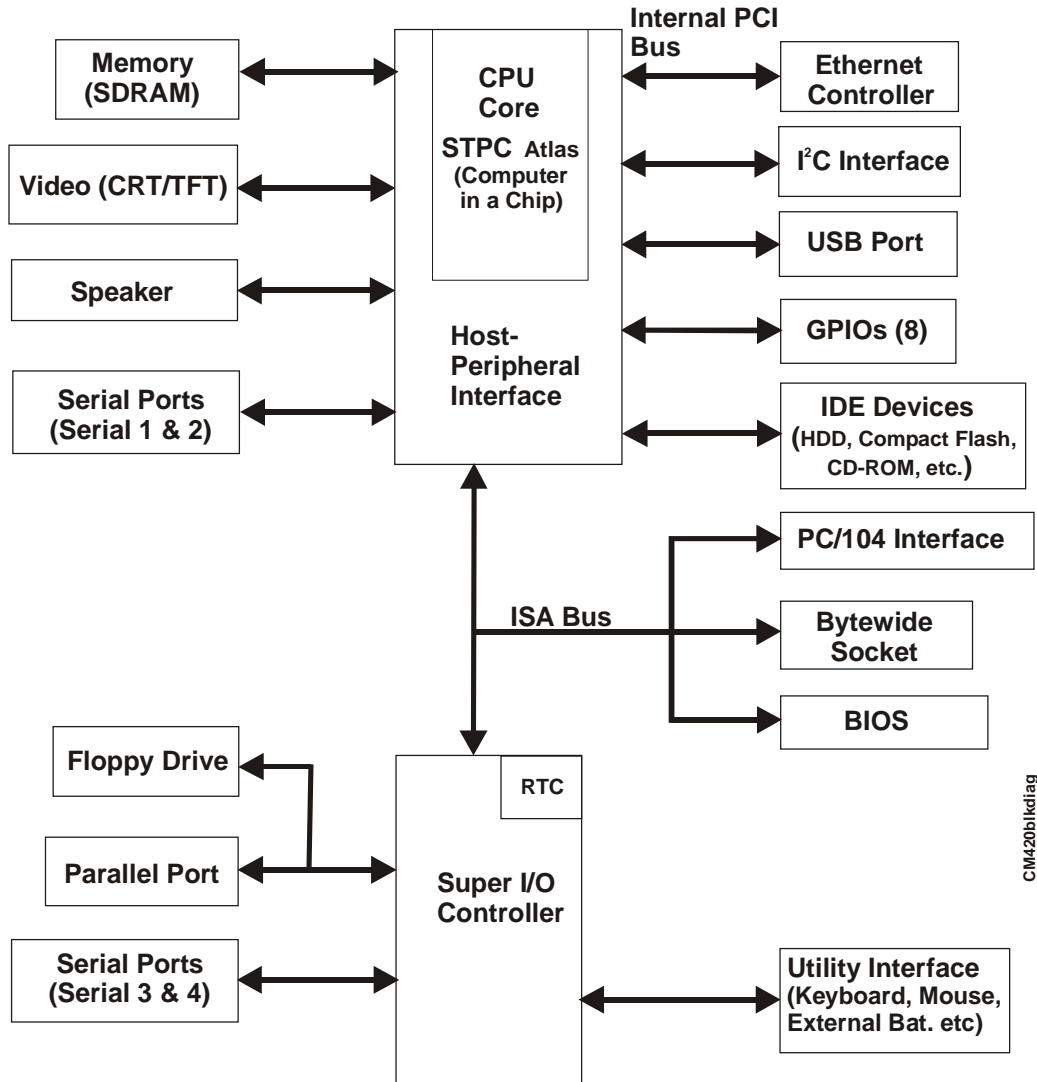

Figure 2-2. Block Diagram

Major Integrated Circuits (ICs)

Table 2-1 lists the major integrated circuits (ICs or chips), including a brief description of each, on the CoreModule 420 and Figure 2-3 shows the location of the major chips.

Table 2-1. Major Integrated Circuit (Chips) Descriptions and Function

Chip Type	Mfg.	Model	Description	Function
CPU (U14)	STMicro-electronics	STPC ATLAS	Embedded CPU – The combination of features in the CPU provide more than just a processor. It also provides a graphics controller, PCI controller, EIDE controller, I/O features, and power management capabilities.	Embedded CPU
Super I/O Controller (U13)	Standard Microsystems Corp.	FDC37B782	Super I/O – This chip provides serial and Floppy controllers	Floppy/Serial Controllers
Ethernet Controller (U15)	Intel	82559ER	Ethernet – This chip provides the 10/100BaseT Ethernet function.	Ethernet

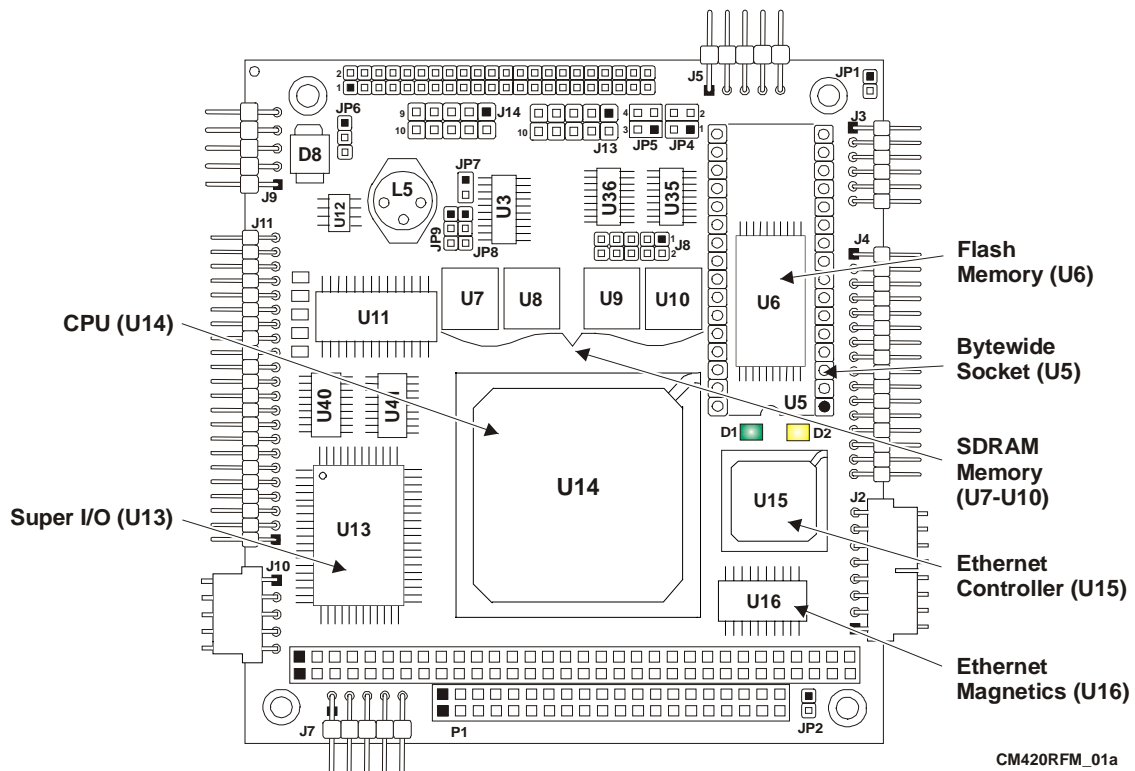

Figure 2-3. Component Locations (Top View)

NOTE

Pin-1 is shown as black pin (square or round) in connectors and jumpers in all illustrations, except where noted.

Connectors, Jumpers, and LEDs

Connector Definitions

Table 2-2 describes the connectors shown in Figures 2-4 to 2-6. Refer to Appendix B for part numbers.

Table 2-2. Connector Descriptions

Jack/Plug #	Access	Description
P1A/1B & P1C/1D – PC/104 Bus	Top/Bottom	104-pin, 0.1", connectors used for PC/104 (ISA) bus
J2 – Ethernet	Top	8-pin, 0.1", connector used for the Ethernet interface
J3 – Serial 1 (COM1)	Top	10-pin, 0.1", connector used for the Serial 1 interface
J4 – Floppy/Parallel	Top	26-pin, 0.1", connector provides the Floppy/Parallel interface
J5 – Utility	Top	10-pin, 0.1", connector used for the Utility interface
J6 – IDE	Top	44-pin, 2 mm connector used for the IDE interface
J7 – Power	Top	10-pin, 0.1", connector used for the Power connection
J8 – GPIO (User)	Top	10-pin, 2 mm connector used for the User defined GPIO signals
J9 – Serial 2 (COM2)	Top	10-pin, 0.1", connector used for the Serial 2 interface
J10 – USB	Top	5-pin, 0.1", connector used for the USB interface
J11 – Video	Top	44-pin, 2 mm connector used for the LCD/CRT interface
J12 – Compact Flash	Bottom	50-pin, 1.27 mm, socket used for compact flash cards
J13 – Serial 3 (COM3)	Top	10-pin, 0.1", connector used for the Serial 3 interface
J14 – Serial 4 (COM4)	Top	10-pin, 0.1", connector used for the Serial 4 interface

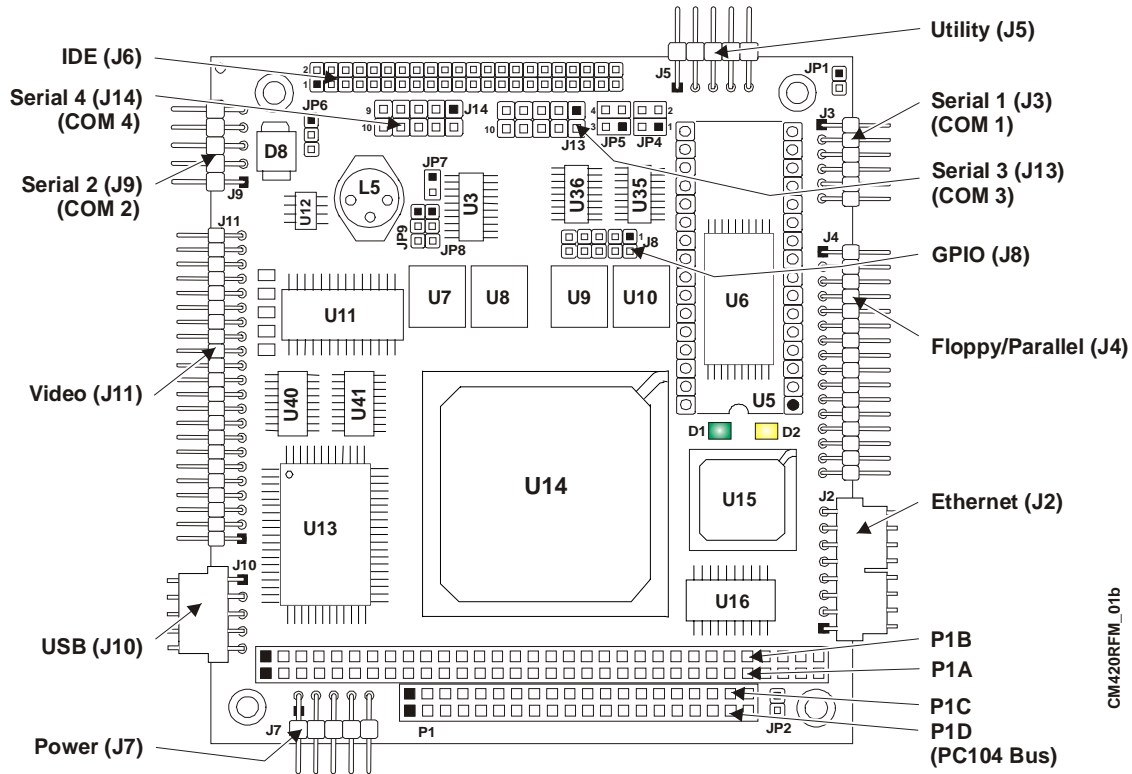



Figure 2-4. Connector Locations (Top View)

CM420REFM_01b

Jumper Definitions

Table 2-3 describes the jumpers shown in Figure 2-5.

Table 2-3. Jumper Settings

Jumper #	Installed	Removed/Installed
JP1 Serial Port 2 Termination	Enable RS-485 Termination (Pins 1-2)	Disable RS-485 Termination (Removed) Default setting
JP2 Serial Port 1 Termination	Enable RS-485 Termination (Pins 1-2)	Disable RS-485 Termination (Removed) Default setting
JP4 & JP5 BIOS/DOC Select  BIOS/DOC Select Jumper Setting (Shown in Default)	Enable Internal BIOS – Normal operation, (Pins 1-3 on both JP4 & JP5)	Disabled – Won't Boot (See other positions)
	Enable External BIOS – Used for recovery (Pins 1-2 on both JP4 & JP5)	Disabled – Won't Boot (See other positions)
	Enable DOC – Boot from DiskOnChip in bytewise socket (Pins 1-3 & 2-4 on both JP4 & JP5) Default setting	Disabled – Won't Boot (See other positions)
JP6 Flat Panel Voltage Selection	+3.3 Volts (Pins 1-2) Default setting	+5 Volts (Pins 2-3)
JP7 DiskOnChip Boot Address Select	Access from DC000h-DDFFFh (Pins 1-2) Default setting	Access from CC000h-CDFFFh (Removed)
JP8 Serial Port 1	Enable Serial Port 1 (Pins 1-2) Default setting	Disabled Serial Port 1 (Pins 2-3)
JP9 Serial Port 2	Enable Serial Port 2 (Pins 1-2) Default setting	Disabled Serial Port 2 (Pins 2-3)

Notes: The jumpers use 2 mm pin spacing. JP8 and JP9 Enable/Disable the Serial ports at the STPC Altas CPU (U14).

LED Definitions

Table 2-4 provides the LED color and definitions for the Ethernet Port (J2) located on the CoreModule 420 and Figure 2-5 provides the locations.

Table 2-4. Ethernet Port (J2) LED Indicators

Indicator	Definition
Ethernet Link/Activity LED (D1)	<p>Link/Activity LED – This yellow LED is the link/ activity indicator and provides the status of Ethernet port (J2).</p> <p>The Link/Activity LED indicates a link is established with either transmit or receive activity.</p> <p>Yellow On – This indicates a link is present.</p> <p>Yellow Flashing – This indicates activity is present.</p> <p>Yellow Off – This indicates no link or activity is present.</p>
Ethernet Speed (D2)	<p>Speed LED – This green LED is the LAN Speed indicator and indicates the transmit or receive speed of Ethernet port (J2).</p> <p>Green On – This indicates the operating speed is 100 Mbps</p> <p>Green Off – This indicates the operating speed is 10 Mbps.</p>

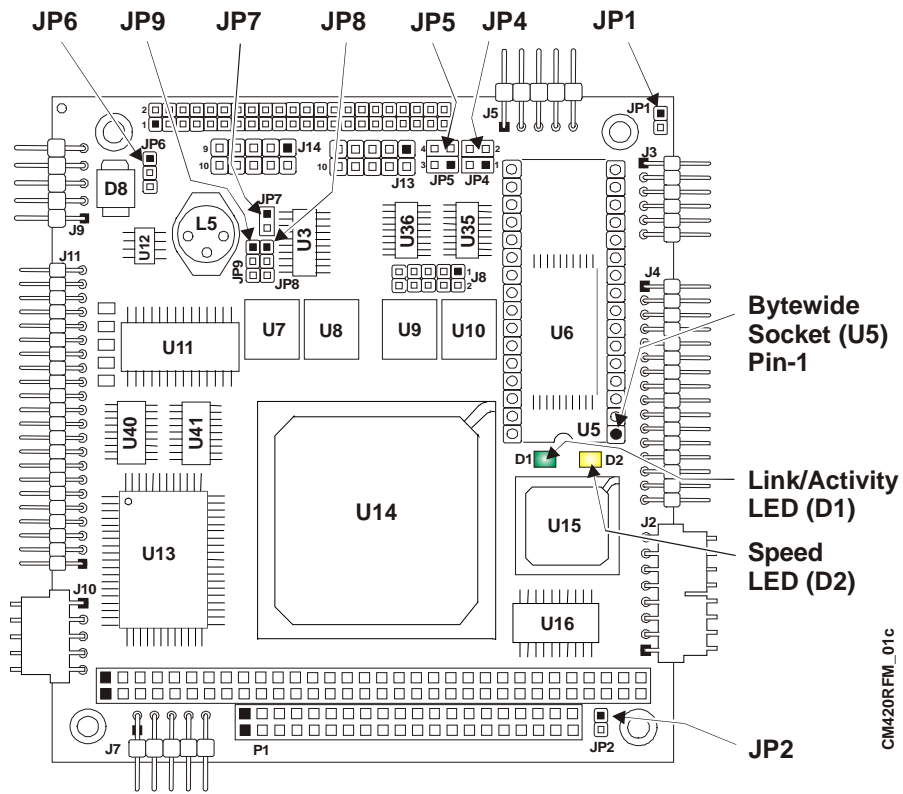

CM420RFM_01c

Figure 2-5. Jumper and LED Locations (Top View)

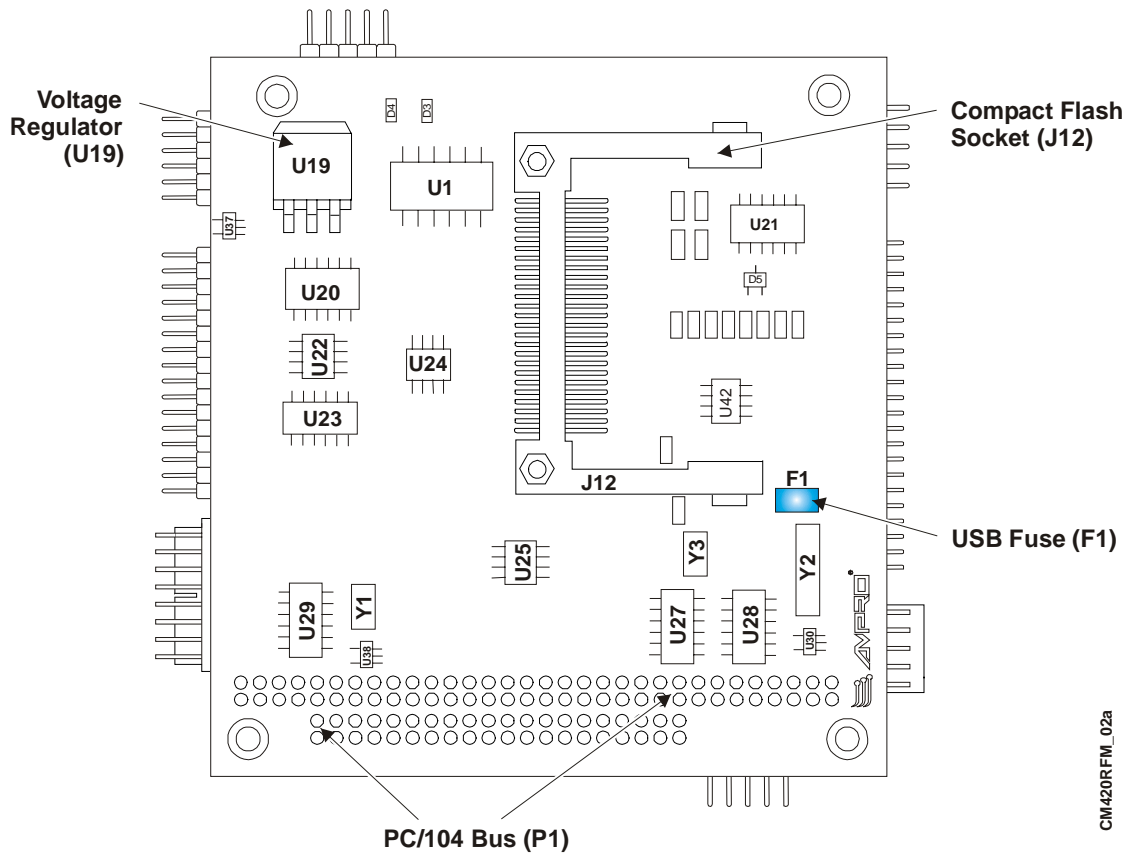

CM420RFM_02a

Figure 2-6. Connector Location (Bottom View)

Specifications

Physical Specifications

Table 2-5 gives the physical dimensions of the module and Figure 2-7 gives the mounting dimensions.

Table 2-5. Weight and Footprint Dimensions

Item	Dimension
Weight	0.0925 kg. (0.204 lbs.)
Height (upper surface)	10.99 mm (0.43") See also Note on page 15.
Width	90.2 mm (3.6")
Length	95.9 mm (3.8")

NOTE Height is measured from the upper board surface to the highest permanent component (PC/104 connector) on the upper board surface. This does not include the heatsink.

Mechanical Specifications

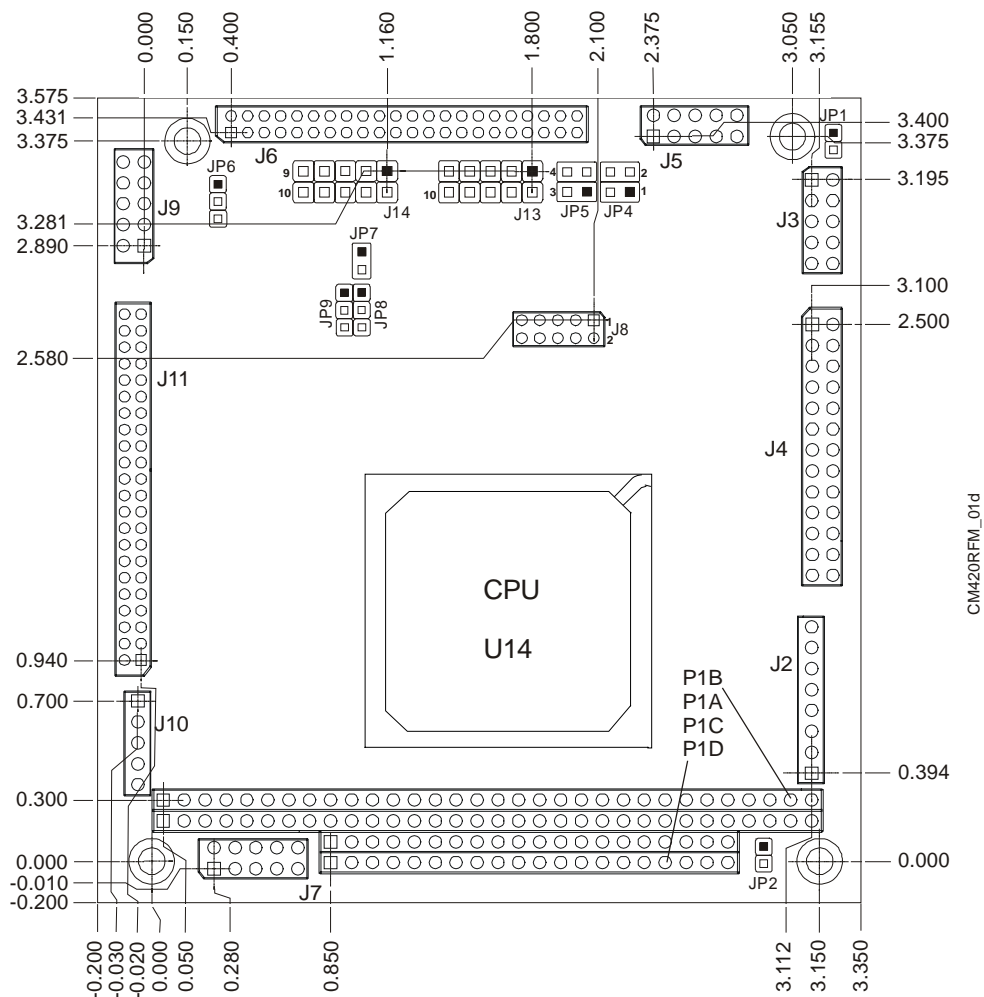

Figure 2-7. Mechanical Dimensions (Top View)

NOTE All dimensions are given in inches. Pin-1 is shown as a black or white pin (square or round) in connectors and jumpers in this illustration.

NOTE	The CoreModule 420 is in violation of the PC/104 height limitations in two places on the bottom of the board. The voltage regulator (U19) exceeds the allowed height limitation by 0.085 inches and the compact flash socket (J12) exceeds the height limitation by 0.2 inches. See Figure 2-6.
-------------	---

Power Specifications

Table 2-6 provides the power requirements.

Table 2-6. Power Supply Requirements

Parameter	Characteristics
Input Type	Regulated DC voltages
In-rush* Current	+5 VDC +/- 5% @ 13.72 Amps
BIT** Current (Typical)	+5 VDC +/- 5% @ 1.51 Amps (7.56W)

Notes: *In-rush measured with video, 64 MB memory (fixed), and power connected. Typically, in-rush current reflects the short duration current spike associated with charging large on-board bulk capacitance during power supply start up. However, the in-rush current value is the result of placing a switch on the DC output of a fully 'ramped' power supply to give a worst-case current value, which is much higher than the standard method. This in-rush value should be regarded as a maximum design guideline, not a requisite or typical value.

**The average BIT (burn in test) current is conducted with 64 MB memory (fixed), a floppy disk drive (FDD), a IDE hard disk drive (HDD), keyboard, mouse, serial loopbacks (4), externally connected USB HDD (1), and active Ethernet channel (1) in a Windows® 2000 operating system (OS) environment.

Environmental Specifications

Table 2-7 provides the operating and storage condition ranges required for this module.

Table 2-7. Environmental Requirements

Parameter	Conditions
Temperature	
Operating	-20° to +70° C (-4° to 158° F)
Extended (Optional)	-40° to +85° C (-40° F to +185° F)
Storage	-55° to +85° C (-67° F to +185° F)
Humidity	
Operating	20% to 80% relative humidity, non-condensing
Non-operating	5% to 95% relative humidity, non-condensing

Thermal/Cooling Requirements

The CPU, Super I/O, and voltage regulator are the sources of heat on the board. The CoreModule 420 is designed to operate at its maximum CPU speed of 133 MHz and requires a heatsink (provided).

Overview

This chapter discusses the chips and connectors of the module features in the following order:

- CPU (U14)
- Memory
 - ◆ SDRAM (U7, U8, U9, U10)
 - ◆ Flash Memory (U6)
 - ◆ Byte-wide socket (U5)
- PC/104 (P1A, B, C, D)
- IDE (J6)
- Compact flash socket (J12)
- Serial (J3, J9, J13, J14)
- Floppy/Parallel (J4)
- Utility (J5)
 - ◆ Keyboard
 - ◆ Mouse
 - ◆ Battery
 - ◆ Reset Switch
 - ◆ Speaker
- Ethernet (J2)
- USB (J10)
- Video (J11)
- Miscellaneous
 - ◆ Time of Day/RTC
 - ◆ User GPIO (J8)
 - ◆ Oops! Jumper (BIOS Recovery)
 - ◆ Watchdog timer
- Power (J7)

NOTE

Ampro Computers, Inc. only supports the features/options tested and listed in this manual. The main integrated circuits (chips) used in the CoreModule 420 may provide more features or options than are listed for the CoreModule 420, but some of these features/options are not supported on the module and will not function as specified in the chip documentation.

CPU (U14)

The CoreModule 420 uses an embedded microprocessor operating at 133 MHz, that combines a powerful x86 core and a selection of peripheral interfaces into one chip. The STPC Atlas integrates a standard 5th generation x86 core. It supports logic including PC/104, EIDE controllers and combines these with standard I/O interfaces to provide a PC compatible subsystem in a single chip.

Memory

The CoreModule 420 memory (storage) consists of the following elements:

- SDRAM
- Flash memory
- Bytewise socket

SDRAM Memory (U7, U8, U9, U10)

The CoreModule 420 contains four 16-bit SDRAM chips of 16 MB each for a total of 64 MB memory soldered into place on the module and operating at 100 MHz.

Flash Memory (U6)

A 1 MB flash device is used for system BIOS on the module and 768 kB is available for user code. The Flash memory also stores system parameters (CMOS settings) and can be used for battery-less boot capability when no battery is available.

Bytewise Socket (U5)

The CoreModule 420 has a 32-pin DIP socket on the module used as a bytewise socket. This socket supports DiskOnChip devices.

A memory device installed in the bytewise socket can be used for:

- DOC2000 (M-Systems DiskOnChip©)
- External BIOS (BIOS recovery)

Memory Map

Table 3-1. Memory Map

Address	Size	Use
1 0000 0000	256 kB	Flash ROM (BIOS)
FFFC 0000	130,560 kB	Unused
F804 0000	128 kB	Ethernet
F802 0000	120 kB	Unused
F800 2000	4 kB	Ethernet
F800 1000	4 kB	USB
F800 0000	3824 MB	Unused
0900 0000	16 MB	STPC Graphics Memory
0800 0000	64 MB	Unused

Memory Map Table continued on next page

Table 3-1. Memory Map (continued)

Address	Size	Use				
0400 0000	1 MB	RAM or Unused if Framebuffer is set to 1 MB or more				
03F0 0000	1 MB	RAM or Unused if Framebuffer is set to 2 MB or more				
03E0 0000	1 MB	RAM or Unused if Framebuffer is set to 3 MB or more				
03D0 0000	1 MB	RAM or Unused if Framebuffer is set to 4 MB				
03C0 0000	44 MB	RAM				
Address	Size	Use				
		Memory hole size selected				
		8 MB	4 MB	2 MB	1 MB	0 MB
0100 0000	1 MB	H	H	H	H	R
00F0 0000	1 MB	H	H	H	R	R
00E0 0000	1 MB	H	H	R	R	R
00D0 0000	1 MB	H	H	R	R	R
00C0 0000	1 MB	H	R	R	R	R
00B0 0000	1 MB	H	R	R	R	R
00A0 0000	1 MB	H	R	R	R	R
0090 0000	1 MB	H	R	R	R	R
		R = RAM H = Memory Hole, forwarded to ISA The board can be configured to have access to the 1 MB Flash anywhere in the memory hole, on 1 MB alignment.				
Address	Size	Use				
0080 0000	7 MB	RAM				
0010 0000	128 kB	Shadowed BIOS				
000E 0000	8 kB	Unused				
000D E000	8 kB	DiskOnChip, if DC000-DDFFF window selected. Unused if no DOC present.				
000D C000	56 kB	Unused				
000C E000	8 kB	DiskOnChip, if CC000-CDFFF window selected. Unused if no DOC present.				
000C C000	48 kB	Unused				
000C 0000	128 kB	Unused, reserved for Video RAM, or in SMI mode, mapped to RAM				
000A 0000 - 0000 0000	640 kB	Base memory				

Interrupt Channel Assignments

The channel interrupt assignments are shown in Table 3-2.

Table 3-2. Interrupt Channel Assignments

Device vs IRQ No.	0	1	2	3	4	5	6	7	8	9	10	11	12	13	14	15	Disable
Timer	X																
Keyboard		X															
Secondary Cascade			X														
COM1					X												Z
COM2				X													Z
COM3				O	O	O	O	O	O	O	D	O	O				Z
COM4				O	O	O	O	O	O	D	O	O	O				Z
Floppy							X										
Parallel				O	O	O	O	D		O	O	O	O				Z
RTC									X								
Prim. IDE															D		Z
Sec. IDE																D	Z
USB				O	O	O	O	O	O	O	O	D	O				Z
Ethernet				O	O	D	O	O	O	O	O	O	O				Z
Math Coprocessor															X		
PS/2 Mouse				O	O	O	O	O		O	O	O	D				Z

Legend: D = Default, O = Optional, X = Fixed, Z = Disable option

NOTE The devices listed with a “Z” in the Disable column indicate the device can be disabled, which will free the IRQ for another device.

Table 3-3. DMA Map

DMA #	Use
0-1, 5, 6, 7	Direct Memory Access
2	Floppy (configurable)
3	LPT 1, only in ECP mode (configurable)
4	DMA 1 cascade

I/O Address Map

Table 3-4. I/O Address Map

Address (hex)	Subsystem
0000-000F	Primary DMA Controller (#1)
0020-0021	Master Interrupt Controller (#1)
0022-0023	STPC Configuration

Address (hex)	Subsystem
0040-0043	Programmable Interrupt Timer (Clock/Timer)
0060-0064	Keyboard Controller
0070-0071	RTC/ NMI enable
0080-008F	DMA Page
0094	Motherboard VGA enable
00A0-00A1	Slave Interrupt Controller (#2)
00C0-00DF	Secondary DMA Controller (#2)
0102	VGA setup register
01F0-01F7	Primary IDE (configurable)
0170-0177	Secondary IDE (configurable)
0201	Watchdog trigger (configurable, disabled by default)
02E8-02EF	COM4 (configurable)
02F8-02FF	COM2 (configurable)
0376	Secondary IDE (see 170)
0378-037B	LPT 1 (configurable, disabled by default)
0378-037F	LPT 1 (only in EPP modes)
03B4-03B5	VGA registers (monochrome mode only)
03BA	VGA registers (monochrome mode only)
03C0-03CF	VGA registers
03D4-03D5	VGA registers (color mode only)
03DA	VGA registers (color mode only)
03E8-03EF	COM3 (configurable)
03F0-03F1	Super I/O Configuration
03F0-03F5, 03F7	Floppy Disk Controller (configurable)
03F6	Primary IDE (see 1F0)
03F8-03FF	COM1 (configurable)
0778-077A	LPT 1 (only in ECP modes)
0CF8	PCI Configuration Address
0CFC-0CFF	PCI Configuration Data
46E8	VGA add-in mode enable register
D000-D007	General Purpose I/O for customer use
D400-D407	Board control
E400-E43F	On-Board Ethernet
E800-E80F	IDE Bus Master registers (PCI mode)
EC00-EC0F	Secondary IDE Control (PCI mode)
F000-F00F	Secondary IDE Command (PCI mode)
F400-F40F	Primary IDE Control (PCI mode)
F800-F80F	Primary IDE Command (PCI mode)

Note: Configurable indicates the device's base address can be configured and/or the device can be disabled, either through BIOS Setup or hardware jumpers.

PC/104 Bus Interface (P1A,B,C,D)

The PC/104 Bus uses a 104-pin 0.1" connector interface. This interface connector will carry all of the appropriate PC/104 signals operating at clock speeds to 8.25 MHz. This interface connector is located on both the top and bottom of the module.

Table 3-5. PC/104 Bus Interface Pin/Signal Descriptions (P1A)

Pin #	Signal	Description (P1 Row A)
1 (A1)	IOCHCHK*	I/O Channel Check – This signal may be activated by ISA boards to request that a non-maskable interrupt (NMI) be generated to the system processor. It is driven active to indicate an uncorrectable error has been detected.
2 (A2)	SD7	System Data 7 – This signal (0 to 19) provides a system data bit.
3 (A3)	SD6	System Data 6 – Refer to SD7, pin A2, for more information.
4 (A4)	SD5	System Data 5 – Refer to SD7, pin A2, for more information.
5 (A5)	SD4	System Data 4 – Refer to SD7, pin A2, for more information.
6 (A6)	SD3	System Data 3 – Refer to SD7, pin A2, for more information.
7 (A7)	SD2	System Data 2 – Refer to SD7, pin A2, for more information.
8 (A8)	SD1	System Data 1 – Refer to SD7, pin A2, for more information.
9 (A9)	SD0	System Data 0 – Refer to SD7, pin A2, for more information.
10 (A10)	IOCHRDY	I/O Channel Ready – This signal allows slower ISA boards to lengthen I/O or memory cycles by inserting wait states. This signal's normal state is active high (ready). ISA boards drive the signal inactive low (not ready) to insert wait states. Devices using this signal to insert wait states should drive it low immediately after detecting a valid address decode and an active read, or write command. The signal is released high when the device is ready to complete the cycle.
11 (A11)	AEN	Address Enable – This signal is reserved for the ISA Bus and is asserted during DMA cycles to prevent I/O slaves from misinterpreting DMA cycles as valid I/O cycles.
12 (A12)	SA19	System Address 19 – These signals (0 to 19) provide system address bits.
13 (A13)	SA18	System Address 18 – Refer to SA19, pin A12, for more information.
14 (A14)	SA17	System Address 17 – Refer to SA19, pin A12, for more information.
15 (A15)	SA16	System Address 16 – Refer to SA19, pin A12, for more information.
16 (A16)	SA15	System Address 15 – Refer to SA19, pin A12, for more information.
17 (A17)	SA14	System Address 14 – Refer to SA19, pin A12, for more information.
18 (A18)	SA13	System Address 13 – Refer to SA19, pin A12, for more information.
19 (A19)	SA12	System Address 12 – Refer to SA19, pin A12, for more information.
20 (A20)	SA11	System Address 11 – Refer to SA19, pin A12, for more information.
21 (A21)	SA10	System Address 10 – Refer to SA19, pin A12, for more information.
22 (A22)	SA9	System Address 9 – Refer to SA19, pin A12, for more information.
23 (A23)	SA8	System Address 8 – Refer to SA19, pin A12, for more information.
24 (A24)	SA7	System Address 7 – Refer to SA19, pin A12, for more information.
25 (A25)	SA6	System Address 6 – Refer to SA19, pin A12, for more information.
26 (A26)	SA5	System Address 5 – Refer to SA19, pin A12, for more information.

Pin #	Signal	Description (P1 Row A)
27 (A27)	SA4	System Address 4 – Refer to SA19, pin A12, for more information.
28 (A28)	SA3	System Address 3 – Refer to SA19, pin A12, for more information.
29 (A29)	SA2	System Address 2 – Refer to SA19, pin A12, for more information.
30 (A30)	SA1	System Address 1 – Refer to SA19, pin A12, for more information.
31 (A31)	SA0	System Address 0 – Refer to SA19, pin A12, for more information.
32 (A32)	GND	Ground

Notes: The shaded area denotes power or ground. The signals marked with * indicate active low.

Table 3-6. PC/104 Bus Interface Pin/Signal Descriptions (P1B)

Pin #	Signal	Description (P1 Row B)
33 (B1)	GND	Ground
34 (B2)	RstDrv	Reset Drive – This signal is used to reset or initialize system logic on power up or subsequent system reset.
35 (B3)	+5V	+5V power $\pm 5\%$
36 (B4)	IRQ9	Interrupt Request 9 – Asserted by a device when it has pending interrupt request. Only one device may use this request line at a time.
37 (B5)	NC	Not connected (-5 volts)
38 (B6)	DRQ2	DMA Request 2 – Used by I/O resources to request DMA service, or to request ownership of the bus as a bus master device. Must be held high until associated DACK2 line is active.
39 (B7)	NC	Not connected (-12 volts)
40 (B8)	ZWS*	Zero Wait State – This signal is driven low by a bus slave device to indicate it is capable of performing a bus cycle without inserting any additional wait states. To perform a 16-bit memory cycle without wait states, this signal is derived from an address decode.
41 (B9)	+12V	+12 Volts
42 (B10)	Key (NC)	Key Pin with plug inserted (Not Connected)
43 (B11)	SMemW*	System Memory Write – This signal is used by bus owner to request a memory device to store data currently on the data bus and only active for the lower 1 MB. Used for legacy compatibility with 8-bit cards.
44 (B12)	SMemR*	System Memory Read – This signal is used by bus owner to request a memory device to drive data onto the data bus and only active for lower 1 MB. Used for legacy compatibility with 8-bit cards.
45 (B13)	IOW*	I/O Write – This strobe signal is driven by the owner of the bus (ISA bus master or DMA controller) and instructs the selected I/O device to capture the write data on the data bus.
46 (B14)	IOR*	I/O Read – This strobe signal is driven by the owner of the bus (ISA bus master or DMA controller) and instructs the selected I/O device to drive read data onto the data bus.
47 (B15)	DACK3*	DMA Acknowledge 3 – Used by DMA controller to select the I/O resource requesting the bus, or to request ownership of the bus as a bus master device. Can also be used by the ISA bus master to gain control of the bus from the DMA controller.
48 (B16)	DRQ3	DMA Request 3 – Used by I/O resources to request DMA service. Must be held high until associated DACK3 line is active.

Pin #	Signal	Description (P1 Row B)
49 (B17)	DACK1*	DMA Acknowledge 1 – Used by DMA controller to select the I/O resource requesting the bus, or to request ownership of the bus as a bus master device. Can also be used by the ISA bus master to gain control of the bus from the DMA controller.
50 (B18)	DRQ1	DMA Request 1 – Used by I/O resources to request DMA service. Must be held high until associated DACK1 line is active.
51 (B19)	Refresh*	Memory Refresh – This signal is driven low to indicate a memory refresh cycle is in progress. Memory is refreshed every 15.6 usec.
52 (B20)	SysClk*	System Clock – This is a free running clock typically in the 8 MHz to 10 MHz range, although its exact frequency is not guaranteed.
53 (B21)	IRQ7	Interrupt Request 7 – Asserted by a device when it has pending interrupt request. Only one device may use the request line at a time.
54 (B22)	IRQ6	Interrupt Request 6 – Asserted by a device when it has pending interrupt request. Only one device may use the request line at a time.
55 (B23)	IRQ5	Interrupt Request 5 – Asserted by a device when it has pending interrupt request. Only one device may use the request line at a time.
56 (B24)	IRQ4	Interrupt Request 4 – Asserted by a device when it has pending interrupt request. Only one device may use the request line at a time.
57 (B25)	IRQ3	Interrupt Request 3 – Asserted by a device when it has pending interrupt request. Only one device may use the request line at a time.
58 (B26)	DACK2*	DMA Acknowledge 2 – Used by DMA controller to select the I/O resource requesting the bus, or to request ownership of the bus as a bus master device. Can also be used by the ISA bus master to gain control of the bus from the DMA controller.
59 (B27)	TC	Terminal Count – This signal is a pulse to indicate a terminal count has been reached on a DMA channel operation.
60 (B28)	BALE	Buffered Address Latch Enable – This signal is used to latch the LA23 to LA17 signals or decodes of these signals. Addresses are latched on the falling edge of BALE. It is forced high during DMA cycles. When used with AENx, it indicates a valid processor or DMA address.
61 (B29)	+5V	+5V power $\pm 5\%$
62 (B30)	OSC	Oscillator – This clock signal operates at 14.3 MHz. This signal is not synchronous with the system clock (SYSCLK).
63 (B31)	GND	Ground
64 (B32)	GND	Ground

Notes: The shaded area denotes power or ground. The signals marked with * indicate active low.

Table 3-7. PC/104 Bus Interface Pin/Signal Descriptions (P1C)

Pin #	Signal	Description (P1 Row C)
1 (C0)	GND	Ground
2 (C1)	SBHE*	System Byte High Enable – This signal is driven low to indicate a transfer of data on the high half of the data bus (D15 to D8).
3 (C2)	LA23	Latchable Address 23 – This signal must be latched by the resource if the line is required for the entire data cycle.
4 (C3)	LA22	Latchable Address 22 – Refer to LA23, pin C2, for more information.
5 (C4)	LA21	Latchable Address 21 – Refer to LA23, pin C2, for more information.

Pin #	Signal	Description (P1 Row C)
6 (C5)	LA20	Latchable Address 20 – Refer to LA23, pin C2, for more information.
7 (C6)	LA19	Latchable Address 19 – Refer to LA23, pin C2, for more information.
8 (C7)	LA18	Latchable Address 18 – Refer to LA23, pin C2, for more information.
9 (C8)	LA17	Latchable Address 17 – Refer to LA23, pin C2, for more information.
10 (C9)	MemR*	Memory Read – This signal instructs a selected memory device to drive data onto the data bus. It is active on all memory read cycles.
11 (C10)	MemW*	Memory Write – This signal instructs a selected memory device to store data currently on the data bus. It is active on all memory write cycles.
12 (C11)	SD8	System Data 8 – Refer to SD7, pin A2, for more information.
13 (C12)	SD9	System Data 9 – Refer to SD7, pin A2, for more information.
14 (C13)	SD10	System Data 10 – Refer to SD7, pin A2, for more information.
15 (C14)	SD11	System Data 11 – Refer to SD7, pin A2, for more information.
16 (C15)	SD12	System Data 12 – Refer to SD7, pin A2, for more information.
17 (C16)	SD13	System Data 13 – Refer to SD7, pin A2, for more information.
18 (C17)	SD14	System Data 14 – Refer to SD7, pin A2, for more information.
19 (C18)	SD15	System Data 15 – Refer to SD7, pin A2, for more information.
20 (C19)	Key (NC)	Key Pin with plug inserted. (Not Connected)

Notes: The shaded area denotes power or ground. The signals marked with * indicate active low.

Table 3-8. PC/104 Bus Interface Pin/Signal Descriptions (P1D)

Pin #	Signal	Description (P1 Row D)
21 (D0)	GND	Ground
22 (D1)	MCS16*	Memory Chip Select 16 – This signal is driven low by a memory slave device to indicate it is capable of performing a 16-bit memory data transfer. This signal is driven from a decode of the LA23 to LA17 address lines.
23 (D2)	IOCS16*	I/O Chip Select 16 – This signal is driven low by an I/O slave device to indicate it is capable of performing a 16-bit I/O data transfer. This signal is driven from a decode of the SA15 to SA0 address lines.
24 (D3)	IRQ10	Interrupt Request 10 – Asserted by a device when it has pending interrupt request. Only one device may use the request line at a time.
25 (D4)	IRQ11	Interrupt Request 11 – Asserted by a device when it has pending interrupt request. Only one device may use the request line at a time.
26 (D5)	IRQ12	Interrupt Request 12 – Asserted by a device when it has pending interrupt request. Only one device may use the request line at a time.
27 (D6)	IRQ15	Interrupt Request 15 – Asserted by a device when it has pending interrupt request. Only one device may use the request line at a time.
28 (D7)	IRQ14	Interrupt Request 14 – Asserted by a device when it has pending interrupt request. Only one device may use the request line at a time.
29 (D8)	DACK0*	DMA Acknowledge 0 – Used by DMA controller to select the I/O resource requesting the bus, or to request ownership of the bus as a bus master device. Can also be used by the ISA bus master to gain control of the bus from the DMA controller.
30 (D9)	DRQ0	DMA Request 0 – Used by I/O resources to request DMA service. Must be held high until associated DACK0 line is active.

Pin #	Signal	Description (P1 Row D)
31 (D10)	DACK5*	DMA Acknowledge 5 – Used by DMA controller to select the I/O resource requesting the bus, or to request ownership of the bus as a bus master device. Can also be used by the ISA bus master to gain control of the bus from the DMA controller.
32 (D11)	DRQ5	DMA Request 5 – Used by I/O resources to request DMA service. Must be held high until associated DACK5 line is active.
33 (D12)	DACK6*	DMA Acknowledge 6 – Used by DMA controller to select the I/O resource requesting the bus, or to request ownership of the bus as a bus master device. Can also be used by the ISA bus master to gain control of the bus from the DMA controller.
34 (D13)	DRQ6	DMA Request 6 – Used by I/O resources to request DMA service. Must be held high until associated DACK6 line is active.
35 (D14)	DACK7*	DMA Acknowledge 7 – Used by DMA controller to select the I/O resource requesting the bus, or to request ownership of the bus as a bus master device. Can also be used by the ISA bus master to gain control of the bus from the DMA controller.
36 (D15)	DRQ7	DMA Request 7 – Used by I/O resources to request DMA service. Must be held high until associated DACK7 line is active.
37 (D16)	+5V	+5V Power $\pm 5\%$
38 (D17)	Master*	Bus Master Assert – This signal is used by an ISA board along with a DRQ line to gain ownership of the ISA bus. Upon receiving a -DACK a device can pull -MASTER low which will allow it to control the system address, data, and control lines. After -MASTER is low, the device should wait one CLK period before driving the address and data lines, and two clock periods before issuing a read or write command.
39 (D18)	GND	Ground
40 (D19)	GND	Ground

Notes: The shaded area denotes power or ground. The signals marked with * indicate active low.

IDE Interface (J6)

The IDE device signals are provided through the standard 44-pin, 2 mm connector (J6).

The IDE interface supports the following features:

- Master mode PCI supporting Enhanced IDE devices
- Supports two EIDE devices
- Full scatter-gather capability
- Supports ATAPI compliant devices including DVD
- Supports IDE native and ATA compatibility modes

Table 3-9 gives the signals for the 44-pins of the IDE 2 mm header.

Table 3-9. IDE Interface Pin/Signal Descriptions (J6)

Pin #	Signal	Description
1	RESET*	Low active hardware reset (RSTDRV inverted)
2	GND	Ground
3	D7	Disk Data 7 – These pins (0 to 15) provide disk data.
4	D8	Disk Data 8 – Refer to pin 3, D7, for more information.
5	D6	Disk Data 6 – Refer to pin 3, D7, for more information.
6	D9	Disk Data 9 – Refer to pin 3, D7, for more information.
7	D5	Disk Data 5 – Refer to pin 3, D7, for more information.
8	D10	Disk Data 10 – Refer to pin 3, D7, for more information.
9	D4	Disk Data 4 – Refer to pin 3, D7, for more information.
10	D11	Disk Data 11 – Refer to pin 3, D7, for more information.
11	D3	Disk Data 3 – Refer to pin 3, D7, for more information.
12	D12	Disk Data 12 – Refer to pin 3, D7, for more information.
13	D2	Disk Data 2 – Refer to pin 3, D7, for more information.
14	D13	Disk Data 13 – Refer to pin 3, D7, for more information.
15	D1	Disk Data 1 – Refer to pin 3, D7, for more information.
16	D14	Disk Data 14 – Refer to pin 3, D7, for more information.
17	D0	Disk Data 0 – Refer to pin 3, D7, for more information.
18	D15	Disk Data 15 – Refer to pin 3, D7, for more information.
19	GND	Ground
20	Key/GND	Key pin plug/Ground
21	DMARQ	DMA Request – Used for DMA transfers between host and drive (direction of transfer controlled by PIOR* and PIOW*). Also used in an asynchronous mode with PDAK*. Drive asserts PIRQ when ready to transfer or receive data.
22	GND	Ground
23	PIOW*	Drive I/O Write – Strobe signal for write functions. Negative edge enables data from a register or data port of the drive onto the host data bus. Positive edge latches data at the host.
24	GND	Ground

Pin #	Signal	Description
25	PIOR*	Drive I/O Read – Strobe signal for read functions. Negative edge enables data from a register or data port of the drive onto the host data bus. Positive edge latches data at the host.
26	GND	Ground
27	IOChRdy	I/O Channel Ready – When negated, extends the host transfer cycle of any host register access when the drive is not ready to respond to a data transfer request. High impedance if asserted.
28	Reserved	Reserved – Not used (through 470 ohm resistor to ground)
29	PDACK*	DMA Channel Acknowledge – Used by the host to acknowledge data has been accepted or data is available. Used in response to DMARQ asserted.
30	GND	Ground
31	PIRQ	Interrupt Request – Asserted (IRQ 14) by drive when it has pending interrupt request (PIO transfer of data to or from the drive to the host).
32	NC	Not connected
33	LA18	Latch Address 18 – Used to indicate which byte in the ATA command block or control block is being accessed.
34	NC	Not connected (through 0.047 µf capacitor to ground)
35	LA17	Latch Address 17 – Used to indicate which byte in the ATA command block or control block is being accessed.
36	LA19	Latch Address 19 – Used to indicate which byte in the ATA command block or control block is being accessed
37	CS1*	Chip Select 1 – Used to select the host-accessible Command Block Register.
38	CS3*	Chip Select 3 – Used to select the host-accessible Command Block Register.
39	Reserved	Reserved – Not used
40	GND	Ground
41	+5V	+5 volts ±5% supply
42	+5V	+5 volts ±5% supply
43	GND	Ground
44	NC	Not connected

Notes: The shaded area denotes power or ground. The signals marked with * indicate active low.

Compact Flash Socket Interface (J12)

The CoreModule 420 provides a compact flash socket, which allows for the insertion of a compact flash card (Type I or II). The compact flash card acts as a standard IDE Drive and is the only device connected to the Secondary IDE bus. If a compact flash card is installed, it must be set in BIOS Setup as [CF on Sec Master] and is hardwired for master mode.

NOTE	Supports True IDE Mode and Type I or Type II compact flash cards in the compact flash socket (J12).
-------------	---

Table 3-10. Compact Flash Socket Interface Pin/Signal Descriptions (J12)

Pin #	Signal	Description
1	GND	Ground
2	D3	Disk Data 3 – These signals (D0-D15) carry the Data, Commands, and Status between the host and the controller. D0 is the LSB of the even Byte of the Word. D8 is the LSB of the Odd Byte of the Word. All Task File operations occur in byte mode on the low order bus D0-D7, while all data transfers are 16 bit using D0-D15 provide the disk data signals.
3	D4	Disk Data 4 – Refer to pin 2, D3, for more information.
4	D5	Disk Data 5 – Refer to pin 2, D3, for more information.
5	D6	Disk Data 6 – Refer to pin 2, D3, for more information.
6	D7	Disk Data 7 – Refer to pin 2, D3, for more information.
7	CE1*	Card Enable 1 – This signal, along with CE2*, is used to select the card and indicate to the card when a byte or word operation is being performed. This signal accesses the even byte or odd byte of the word depending on A0 and CE2*.
8, 9	GND	Ground
10, 11	GND	Ground
12	GND	Ground
13	Vcc	+5 volts $\pm 5\%$ power supply
14, 15	GND	Ground
16, 17	GND	Ground
18	A2	Address Select 2 – One of three signals (0 – 2) used to select one of eight registers in the Task File. The host grounds all remaining address lines.
19	A1	Address Select 1 – Refer to A2 on pin-18 for more information.
20	A0	Address Select 0 – Refer to A2 on pin-18 for more information.
21	D0	Disk Data 0 – Refer to D3 on pin-2 for more information.
22	D1	Disk Data 1 – Refer to D3 on pin-2 for more information.
23	D2	Disk Data 2 – Refer to D3 on pin-2 for more information.
24	NC	Not connected – (IOCS16*)
25	GND	Ground
26	NC	Not Connected (Card detect)

Pin #	Signal	Description
27	D11	Disk Data 11 – Refer to pin 2, D3, for more information.
28	D12	Disk Data 12 – Refer to pin 2, D3, for more information.
29	D13	Disk Data 13 – Refer to pin 2, D3, for more information.
30	D14	Disk Data 14 – Refer to pin 2, D3, for more information.
31	D15	Disk Data 15 – Refer to pin 2, D3, for more information.
32	CE2*	Card Enable 2 – This signal, along with CE1*, is used to select the compact flash card and indicate to the card when a byte or word operation is being performed. This signal always accesses the odd byte of the word.
33	NC	Not Connected (VS1*)
34	IOR*	I/O Read Strobe – This signal is generated by the host and gates the I/O data onto the bus from the compact flash card when the card is configured to use the I/O interface.
35	IOW*	I/O Write Strobe – This signal is generated by the host and clocks the I/O data on the Card Data bus into the compact flash card controller registers when the card is configured to use the I/O interface. The clock occurs on the negative to positive edge of the signal (trailing edge).
36, 38	Vcc	+5 volts \pm 5% power
37	RDY	Drive Ready – IRQ (IRQ 15) is asserted by drive (CF) when it has a pending interrupt request (PIO transfer of data to or from the drive to the host).
39	GND	Grounded (CSEL)
40	NC	Not Connected (VS2*)
41	IDERst*	IDE Reset – This input signal is the active low hardware reset from the host. If this pin goes high, it is used as the reset signal. This pin is driven high at power-up, causing a reset, and if left high will cause another reset.
42	IORDY	I/O Channel Ready – When negated, extends the host transfer cycle of any host register access when the drive is not ready to respond to a data transfer request. High impedance if asserted.
43	NC	Not Connected – (INPACK)
44	REG*	Registered/Common Memory Access – Tied high for Common Memory Access.
45	ACT/SLV	Drive Active/Slave Present – Tied high for Master/Slave handshake protocol.
46	NC	Not Connected (PDIAG)
47	D8	Disk Data 8 – Refer to pin 2, D3, for more information.
48	D9	Disk Data 9 – Refer to pin 2, D3, for more information.
49	D10	Disk Data 10 – Refer to pin 2, D3, for more information.
50	NC	Not Connected (CD2)

Notes: The shaded area denotes power or ground. The signals marked with * = Negative true logic.

Floppy/Parallel Interface (J4)

Floppy Disk Drive Port

The Super I/O chip provides the Floppy Disk Controller and the Parallel Port interface (J4). The Floppy Drive interface shares the same connector as the Parallel Port and the signals are multiplexed out of the connector. However, you can only use one of these devices at a time and it must be configured in BIOS Setup Utility. The default device in the BIOS Setup Utility is the Floppy Drive.

The Floppy Disk Controller supports two floppy disk drives from 360 kB through 2.88 MB and is configured as the floppy interface in the BIOS.

NOTE Due to the multiplexed nature of the signals for the floppy disk and parallel connector, you can only connect one of these devices at a time. Refer to *Chapter 4, BIOS Setup* later in this manual when selecting the floppy or parallel device in the BIOS Setup Utility.

Parallel Port

The Super I/O chip provides the Parallel Port interface and Floppy Disk Controller, which share the same output connector (J4). The Parallel Port supports the standard parallel, Bi-directional, Standard Printer Port (SPP), Enhanced Parallel Port (EPP), and Enhanced Capabilities Port (ECP) protocols.

Table 3-11. Floppy/Parallel Interface Pin/Signal Descriptions (J4)

Pin #	Signal	Description
1	Strobe*	Strobe* – This is an output signal used to strobe data into the printer. I/O pin in ECP/EPP mode.
	DS0*	Drive Select 0 – Selects floppy drive 0.
2	AutoFD*	Auto Feed* – This is a request signal into the printer to automatically feed one line after each line is printed.
	DRV0	Floppy Drive Density Select 0 – This signal indicates a low (250/300 kbps) or high (500 kbps) data rate has been selected.
3	PD0	Parallel Port Data 0 – These pins (0 to 7) provides parallel port data signals.
	INDEX	Index – Sense detects the head is positioned over the beginning of a track
4	ERR*	Error – This is a status output signal from the printer. A Low State indicates an error condition on the printer.
	HDSEL	Head Select – Selects the side for Read/Write operations (0 = side 1, 1 = side 0)
5	PD1	Parallel Port Data 1 – Refer to pin-3, PDO for more information.
	TRK0	Track 0 – Indicates when the head is positioned over track 0 (outermost track).
6	INIT*	Initialize* – This signal is used to Initialize printer. Output in standard mode, I/O in ECP/EPP mode.
	DIR	Direction – This signal determines direction of head movement (0 = inward motion, 1 = outward motion).
7	PD2	Parallel Port Data 2 – Refer to pin-3, PDO for more information.
	WRPRT	Write Protect – Senses the diskette is write protected.

Pin #	Signal	Description
8	SLIN	Select In – This output signal is used to select the printer. I/O pin in ECP/EPP mode.
	STEP	Step – Low step pulse for each track-to-track movement of the head.
9	PD3	Parallel Port Data 3 – Refer to pin-3, PDO for more information.
	RDATA	Read Data – Raw serial bit stream from the drive for read operations.
10	GND	Ground
11	PD4	Parallel Port Data 4 – Refer to pin-3, PDO for more information.
	DskChg	Disk Change – Senses the drive door is open or the diskette has been changed since the last drive selection.
12	GND	Ground
13	PD5	Parallel Port Data 5 – Refer to pin-3, PDO for more information.
14	GND	Ground
15	PD6	Parallel Port Data 6 – Refer to pin-3, PDO for more information..
	MTR0*	Motor Control 0 – Selects or enables the motor on floppy drive 0.
16	GND	Ground
17	PD7	Parallel Port Data 7 – Refer to pin-3, PDO for more information.
18	GND	Ground
19	Ack*	Acknowledge* – This is a status output signal from the printer. A Low State indicates it has received the data and is ready to accept new data.
	DS1	Drive Select 1 – Selects floppy drive 1.
20	GND	Ground
21	Busy*	Busy* – This is a Status output signal from the printer. A High State indicates the printer is not ready to accept data.
	MTR1	Motor Control 1 – Selects or enables the motor on floppy drive 1.
22	GND	Ground
23	PE	Paper End – This is a status output signal from the printer. A High State indicates it is out of paper.
	WDATA	Write Data – Encoded data to the drive for write operations.
24	GND	Ground
25	Slct	Select – This is a status output signal from the printer. A High State indicates it is selected and powered on.
	WGATE	Write Gate – Signal to the drive to enable current flow in the write head.
26	Key/NC	Key Pin/Not Connected

Notes: The shaded area denotes power or ground. The signals marked with * indicate active low.

Serial Interface (J3, J9, J13, J14)

The Atlas CPU and Super I/O chips each contain the circuitry for two of the four serial ports. The Atlas CPU provides serial port 1 (J3) and serial port 2 (J9) through the two independent 10-pin connectors. The Super I/O chip provides serial ports 3 (J13) and 4 (J14). The serial ports support the following features:

- Programmable word length, stop bits and parity
- 16-bit programmable baud rate generator
- Interrupt generator
- Loop-back mode
- 16-bit FIFOs for each port
- Ports 1 and 2 are supported by the STPC Atlas processor and are 16540 compatible
 - ◆ Serial 1 (J3, COM1) supports RS-232/RS-485 and has full modem operation
 - ◆ Serial 2 (J9, COM2) supports RS-232/RS-485 and has full modem operation
- Ports 3 and 4 are supported by the Super I/O Controller and are 16550 compatible
 - ◆ Serial 3 (J13, COM3) supports RS-232 with full modem support
 - ◆ Serial 4 (J14, COM4) supports RS-232 with full modem support

NOTE The RS-232/RS-485 mode for Serial Port 1 (COM1) and Serial Port 2 (COM2) are selected in BIOS Setup Utility. However, the RS-232 mode is the default (Standard) for any serial port.

RS-485 mode termination is selected with jumper JP2 Serial 1 (COM1) and JP1 Serial 2 (COM2) on the module. Refer to Table 2-3 for more information.

To implement the two-wire RS-485 mode on either serial port, you must tie the equivalent pins together for the selected port.

For example; you must tie pins 3 (Rx Data –) to 5 (Tx Data –) and pins 4 (Tx Data +) to 6 (Rx Data +) at Serial Port 1 or 2 (J3 or J9) for the two-wire interface. As an alternate, you may short the equivalent pins on the DB9 connector attached to respective serial port, as shown in Figure 3-1. Refer also to the following tables for the specific pins on the connectors. The RS-422 mode uses a four-wire interface and does not require combining pins for its operation, but you must select RS-485 in BIOS Setup.



Figure 3-1. RS-485 Serial Port Implementation

Table 3-12 provides the signals for the corresponding pins of the two independent serial interface ports (Serial 1 & 2) and Table 3-13 provides the signals for the corresponding pins of two independent serial interface headers (Serial 3 & 4).

Table 3-12. Serial Ports 1 & 2 Interface Pin/Signal Descriptions (J3, J9)

Pin #	Signal	DB9 #	Description
1	DCD*	1	Data Carrier Detect – Indicates external serial device is detecting a carrier signal (i.e., a communication channel is currently open). In direct connect environments, this input is driven by DTR as part of the DTR/DSR handshake.
2	DSR*	6	Data Set Ready – Indicates external serial device is powered, initialized, and ready. Used as hardware handshake with DTR for overall readiness.
3	RXD Rx Data –	2	Receive Data – Serial port receive data input is typically held at a logic 1 (mark) when no data is being transmitted, and is held “Off” for a brief interval after an “On” to “Off” transition on the RTS line to allow the transmission to complete. Serial Port 1 or 2 – If in RS-485 mode, this pin is Rx Data Negative.
4	RTS* Tx Data +	7	Request To Send – Indicates serial port is ready to transmit data. Used as hardware handshake with CTS for low level flow control. Serial Port 1 or 2 – If in RS-485 mode, this pin is Tx Data Positive.
5	TXD Tx Data –	3	Transmit Data – Serial port transmit data output is typically held to a logic 1 when no data is being sent. Typically, a logic 0 (On) must be present on RTS, CTS, DSR, and DTR before data can be transmitted on this line. Serial Port 1 or 2 – If in RS-485 mode, this pin is Tx Data Negative.
6	CTS* Rx Data +	8	Clear To Send – Indicates external serial device is ready to receive data. Used as hardware handshake with RTS for low level flow control. Serial Port 1 or 2 – If in RS-485 mode, this pin is Rx Data Positive.
7	DTR*	4	Data Terminal Ready – Indicates serial port is powered, initialized, and ready. Used as hardware handshake with DSR for overall readiness.
8	RI*	9	Ring Indicator – Indicates external serial device is detecting a ring condition. Used by software to initiate operations to answer and open the communications channel.
9	GND	5	Ground
10	Key/NC	NC	Key Pin/Not connected

Notes: The shaded area denotes power or ground. The signals marked with * indicate active low.

Table 3-13. Serial Ports 3 & 4 Interface Pin/Signal Descriptions (J13, J14)

Pin #	Signal	DB9 #	Description
1	DCD*	1	Data Carrier Detect – Indicates external serial device is detecting a carrier signal (i.e., a communication channel is currently open). In direct connect environments, this input is driven by DTR as part of the DTR/DSR handshake.
2	DSR*	6	Data Set Ready – Indicates external serial device is powered, initialized, and ready. Used as hardware handshake with DTR for overall readiness.
3	RXD	2	Receive Data – Serial port receive data input is typically held at a logic 1 (mark) when no data is being transmitted, and is held “Off” for a brief interval after an “On” to “Off” transition on the RTS line to allow the transmission to complete.

Pin #	Signal	DB9 #	Description
4	RTS*	7	Request To Send – Indicates serial port is ready to transmit data. Used as hardware handshake with CTS for low level flow control.
5	TXD	3	Transmit Data – Serial port transmit data output is typically held to a logic 1 when no data is being sent. Typically, a logic 0 (On) must be present on RTS, CTS, DSR, and DTR before data can be transmitted on this line.
6	CTS*	8	Clear To Send – Indicates external serial device is ready to receive data. Used as hardware handshake with RTS for low level flow control.
7	DTR*	4	Data Terminal Ready – Indicates serial port is powered, initialized, and ready. Used as hardware handshake with DSR for overall readiness.
8	RI*	9	Ring Indicator – Indicates external serial device is detecting a ring condition. Used by software to initiate operations to answer and open the communications channel.
9	GND	5	Ground
10	Key/NC	NC	Key Pin – Not connected

Notes: The shaded area denotes power or ground. The signals marked with * indicate active low.

USB Interface (J10)

The CoreModule 420 contains one root USB (Universal Serial Bus) hub and one functional USB port. The USB function is provided by the STPC ATLAS CPU (U14). Features implemented in the USB port include the following:

- Provides one root hub with one USB port
- Supports USB v.1.1 and Universal OHCI v.1.0
- Over-current detection status is provided by STPC ATLAS CPU (pin D21)
- Provides a fuse (F1, 1.5A) onboard for over current protection

Table 3-14. USB Interface Pin/Signal Designations (J10)

Pin #	Signal	Description
1	USBPWR	USB Power – Vcc (+5V +/-5%) power goes to the port through an onboard fuse. Port is disabled if this input is low.
2	USBPN	USB Port Data Negative.
3	USBPP	USB Port Data Positive
4	GND	USB Port ground
5	SHIELD	USB Port shield

Note: The shaded area denotes power or ground.

Utility Interface (J5)

The Utility interface provides various utility and I/O signals on the module and consist of a 10-pin, 0.1" header. The Super I/O chip drives most of the signals on the Utility interface. Table 3-15 provides the definition of the interface signals on the utility interface.

- Keyboard and PS/2 Mouse
- Battery
- Reset Switch
- Speaker

Keyboard

The signal lines for an AT or PS/2 keyboard are provided through the Utility interface (J5) to the Super I/O controller (U13). Refer to Table 3-15 for pin-signal information.

Mouse

The signal lines for a PS/2 mouse are provided through the Utility interface (J5) to the Super I/O controller (U13). Refer to Table 3-15 for pin-signal information.

Battery

An external battery input connection is provided through the Utility interface (J5) to support a battery backup for the CMOS RAM and the RTC (Real Time Clock). Refer to Table 3-15 for pin-signal information.

Reset Switch

An external reset switch provides the reset signal through the Utility interface (J5) to a reset circuit, which drives the STPC ATLAS CPU (U14). Refer to Table 3-15 for pin-signal information.

Speaker

The speaker signal provides sufficient signal strength to drive a 1W 8 Ω "Beep" speaker through the Utility interface (J5) at an audible level. The speaker signal is driven from an on board amplifier and the STPC ATLAS CPU (U14). Refer to Table 3-15 for pin-signal information.

Table 3-15. Utility Interface Pin/Signal Descriptions (J5)

Pin #	Signal	Description
1	SPKR	Speaker Output
2	BATV-	Ground return
3	RESETSW*	External Reset Switch signal
4	MDATA	Mouse Data input
5	KBDATA	Keyboard Data input
6	KBCLK	Keyboard Clock input
7	GND	Ground
8	KMPWR	Keyboard /Mouse power (+5V) output
9	BATV+	Real time battery voltage (3.6V Type/ 4.0V Max) input
10	MCLK	Mouse Clock input

Notes: The shaded area denotes power or ground. The signals marked with * indicate active low.

Ethernet Interface (J2)

The Ethernet solution is provided by the Intel 82559ER PCI controller chip and consists of both the Media Access Controller (MAC) and the physical layer (PHY) combined into a single component solution. The 82559ER is a glueless 32-bit PCI controller that features enhanced scatter-gather bus mastering capabilities, which enables the 82559ER to perform high-speed data transfers over the internal PCI bus. The 82559ER glueless bus master capabilities enable the component to process high-level commands and perform multiple operations, thereby off-loading communication tasks from the system CPU. The Ethernet interface offers the following features:

- Full duplex or half-duplex support
- Full duplex support at 10 Mbps or 100 Mbps
- In full duplex mode the 82559ER adheres to the IEEE 802.3x Flow Control specification.
- In half-duplex mode, performance is enhanced by a proprietary collision reduction mechanism.
- IEEE 802.3 10/100BaseT compatible physical layer to wire transformer
- Two on board LEDs support the speed and the link & activity status
- IEEE 802.3u Auto-Negotiation support
- Fast back-to-back transmission support with minimum interframe spacing (IFS).
- IEEE 802.3x auto-negotiation support for speed and duplex operation
- 3 kB transmit and 3 kB receive FIFOs (helps prevent data underflow and overflow)
- IEEE 802.3x 100BaseTX flow control support
- Onboard magnetics (isolation transformer, U16)

Table 3-16 describes the pin-outs of the Ethernet connector J2.

Table 3-16. Ethernet Interface Pin/Signal Descriptions (J2)

Pin #	Signal	Description
1	TX+	Analog Twisted Pair Ethernet Transmit Differential Pair – These pins transmit the serial bit stream through the isolation transformer.
2	TX-	
3	RX+	Analog Twisted Pair Ethernet Receive Differential Pair – These pins receive the serial bit stream through the isolation transformer.
6	RX-	
4	CT	Center Tap – Connected through two 75 ohm resistors in series to center tap of isolation transformer and then to ground through common 1k PF capacitor.
5	CT	
7	CT	Center Tap – Connected through two 75 ohm resistors in series to center tap of isolation transformer and then to ground through common 1k PF capacitor.
8	CT	

NOTE	The magnetics (isolation transformer, U16) for the Ethernet connector is included on the CoreModule 420.
-------------	--

Video (LCD/CRT) Interface (J11)

The STPC Atlas chip provides the 2D graphics controller for the video signals to a flat panel display and traditional glass CRT monitor. The features are listed below:

- Enhanced 2D Graphics Controller
 - ◆ Supports Pixel Depths of 8, 16, 24 and 32 bit
 - ◆ Full BitBLT Implementation for all 256 Raster Operations Defined for Windows
 - ◆ Supports 4 Transparent BLT Modes
 - Bitmap Transparency
 - Pattern Transparency
 - Source Transparency
 - Destination Transparency
 - ◆ Hardware Clipping
 - ◆ Fast Line Draw Engine with anti-aliasing
 - ◆ Fast Triangle Fill Engine
 - ◆ Supports 4-bit Alpha Blend Font for anti-aliased text display
 - ◆ Complete Double Buffered Registers for pipelined operation
 - ◆ 64-bit wide Pipelined Architecture running at 100 MHz
 - ◆ Video memory up to 4 MB; selected in BIOS Setup
- CRT Controller
 - ◆ Integrated 135 MHz triple RAMDAC allowing for 1280 x 1024 x 75 Hz display
 - ◆ Supports 8-, 16-, and 24-bit pixels
 - ◆ Interlaced or non-interlaced output
- TFT Display Controller
 - ◆ Conforms with VESA Flat Panel Display Interface FPDI-1B
 - ◆ Supports both 4/3 and 16/9 screen size ratio
 - ◆ Supports up to 1024 x 768 pixel display resolutions
 - ◆ Uses Internal CRTC Controller for display modes settings
 - ◆ Supports VGA and SVGA active matrix panels with 9-, 12-, 18-bit Interface (1 pixel/clock)
 - ◆ Supports XGA and SXGA active matrix panels with 2x9-bit Interface (2 pixels/clock)
 - ◆ Programmable image position and size
 - ◆ Programmable blank space insertion in text mode
 - ◆ Programmable horizontal and vertical image expansion in graphic mode
 - ◆ Supports PanelLink™ high speed serial transmitter externally for high resolution panel interface.

The video interface (LCD/CRT) uses a 44-pin 2 mm header with pin outs shown in Table 3-17.

Table 3-17. Video Interface Pin/Signal Descriptions (J11)

Pin #	Signal	Description
1	TFTDCLK	TFT Shift Clock – This clock signal provides the timing for transferring digital pixel data.
2	TFTDE	TFT Data Enable – This signal indicates valid data on any of the FP [23:0] lines.
3	TFTLP	TFT Line Pulse – This signal is the digital monitor equivalent of HSYNC.
4	TFTFrame	TFT Frame Marker – This signal is the TFT monitor equivalent of VSYNC.
5	GND	Ground
6	GND	Ground
7	NC	Not connected (FP0 = Panel Data 0)
8	NC	Not connected (FP1 = Panel Data 1)
9	FP2	Panel Data 2 – These pins (0 to 23) provides digital pixel data output signals.
10	FP3	Panel Data 3 – Refer to pin 9, FP2, for more information.
11	FP4	Panel Data 4 – Refer to pin 9, FP2, for more information.
12	FP5	Panel Data 5 – Refer to pin 9, FP2, for more information.
13	FP6	Panel Data 6 – Refer to pin 9, FP2, for more information.
14	FP7	Panel Data 7 – Refer to pin 9, FP2, for more information.
15	NC	Not connected (FP8 = Panel Data 8)
16	NC	Not connected (FP9 = Panel Data 9)
17	FP10	Panel Data 10 – Refer to pin 9, FP2, for more information.
18	FP11	Panel Data 11 – Refer to pin 9, FP2, for more information.
19	FP12	Panel Data 12 – Refer to pin 9, FP2, for more information.
20	FP13	Panel Data 13 – Refer to pin 9, FP2, for more information.
21	FP14	Panel Data 14 – Refer to pin 9, FP2, for more information.
22	FP15	Panel Data 15 – Refer to pin 9, FP2, for more information.
23	NC	Not connected (FP16 = Panel Data 16)
24	NC	Not connected (FP17 = Panel Data 17)
25	FP18	Panel Data 18 – Refer to pin 9, FP2, for more information.
26	FP19	Panel Data 19 – Refer to pin 9, FP2, for more information.
27	FP20	Panel Data 20 – Refer to pin 9, FP2, for more information.
28	FP21	Panel Data 21 – Refer to pin 9, FP2, for more information.
29	FP22	Panel Data 22 – Refer to pin 9, FP2, for more information.
30	FP23	Panel Data 23 – Refer to pin 9, FP2, for more information.
31	TFTEnVcc	TFT Power (Vcc) – This signal is the power to flat panel displays.
32	TFTEnVee	TFT Voltage Enable (Vee) – This signal enables power to flat panel displays.
33	+PNLVdd	Voltage (+3.3 or +5 volts $\pm 5\%$) depends on setting of JP6.
34	+12V Out	+12 volts $\pm 5\%$
35	GND	Ground
36	GND	Ground
37	HSYNC	Horizontal Sync – This signal is used for the digital horizontal sync output to the CRT. Also used (with VSYNC) to signal power management state information to the CRT per the VESA™ DPMS™ standard.

Pin #	Signal	Description
38	VSYNC	Vertical Sync – This signal is used for the digital vertical sync output to the CRT. Also used (with HSYNC) to signal power management state information to the CRT per the VESA™ DPMS™ standard.
39	AGNDR	Analog Ground for Red
40	RED	Red – This pin provides the Red analog output to the CRT.
41	AGNDG	Analog Ground for Green
42	GREEN	Green – This pin provides the Green analog output to the CRT.
43	AGNDB	Analog Ground for Blue
44	BLUE	Blue – This pin provides the Blue analog output to the CRT.

Notes: The shaded area denotes power or ground. The signals marked with * indicate active low.

Miscellaneous

Real Time Clock (RTC)

The CoreModule 420 contains a Real Time (time of day) Clock (RTC), which can be backed up with an external Lithium Battery. The CoreModule 420 will function without a battery in those environments, which prohibit inclusion of batteries. The CoreModule 420 will also continue to operate after the battery life has been exceeded. Under these conditions all setup information is restored from the onboard Flash memory during POST along with the default date and time information.

NOTE	Some operating systems require a valid default date and time to function.
-------------	---

User GPIO Interface

The CoreModule 420 provides GPIO pins for customer use and the signals are routed to connector J8. An example of how to use the GPIO pins is provided in the Miscellaneous Source Code Examples subdirectory, under the CoreModule 420 Software menu on the CoreModule 420 Doc & SW CD-ROM (CD-ROM\Software\Misc\GPIO).

CAUTION	To prevent a system crash, or render the CoreModule 420 BIOS unusable, do not attempt to use the <i>master</i> GPIO pins (GPIOs 0-7). The STPC Atlas processor has two GPIO blocks, master and slave. The slave GPIO pins are reserved for customer applications. The <i>master</i> GPIO pins are dedicated for BIOS use to control on-board peripherals. The <i>master</i> GPIO pins can not be used for customer applications.
----------------	--

The example program can be built by using the *make.bat* file. This produces a 16-bit DOS executable application, *gpio.exe*, which can be run on the CoreModule 420 to demonstrate the use of GPIO pins. For more information about the GPIO pin operation, refer to the Programming Manual for the STPC Atlas processor at:

<http://www.stm32.com/devicedocs-Atlas-75.html>

Table 3-18. User GPIO Interface Pin/Signal Descriptions (J8)

Pin #	Signal	Description
1	GPIO8	User defined
2	GPIO9	User defined
3	GPIO10	User defined
4	GPIO11	User defined
5	GPIO12	User defined
6	GPIO13	User defined
7	GPIO14	User defined
8	GPIO15	User defined
9	GND	Ground
10	GND	Ground

Note: The shaded area denotes ground.

Oops! Jumper (BIOS Recovery)

The Oops! jumper is provided in the event you've selected BIOS settings that prevent you from booting the system. By using the Oops! jumper you can stop the current BIOS settings in the CMOS from being loaded, allowing you to proceed, using the default settings. Connect the DTR pin to the RI pin on Serial port 1 (COM 1) prior to boot up to prevent the present BIOS settings from loading. After booting with the Oops! jumper in place, remove the Oops! jumper and go into BIOS Setup.

To restore your BIOS setting changes without the errors, you must first select *Load Factory Default Settings*, which will automatically load and save the defaults and reboot the system. Then you can modify the default settings to your desired values. Ensure you save the changes before rebooting the system.

NOTE Serial Port 1 (J3) is a 10-pin header and uses pin 7 = DTR and pin 8 = Ri for the Oops! Jumper. At Serial Port 1, short pin 7 to 8, as shown in Figure 3-2. Alternatively, you may short the equivalent pins on the DB9 connector attached to Serial Port 1 as shown in Figure 3-2.



Figure 3-2. Oops! Jumper

Serial Console

The CoreModule 420 BIOS supports the serial console (or console redirection) feature. These I/O functions are provided by an ANSI-compatible serial terminal, or the equivalent terminal emulation software running on another system. This can be very useful when setting up the BIOS on a production line for systems that are not connected to a keyboard and display.

Serial Console BIOS Setup

The serial console (console redirection) feature is implemented by connecting a standard null-modem cable or a modified serial cable (or “Hot Cable”) between one of the serial ports, such as Serial 1 or 2 (J3 or J9), and the serial terminal or a PC with communications software. The BIOS Setup Utility controls the serial console settings on the CoreModule 420. Refer to Chapter 4, BIOS Setup for the serial console option settings and the connection procedure, using the a serial terminal, or PC with communications software.

Hot (Serial) Cable

To convert a standard serial cable to a Hot Cable, certain pins must be shorted together at the Serial port connector or at the DB9 connector. Short together the RTS (4) and RI (8) pins on either serial port (J3 or J9) header. As an alternate, you can short the equivalent pins (pins 7 and 9) on the respective DB9 port connector as shown in Figure 3-3.

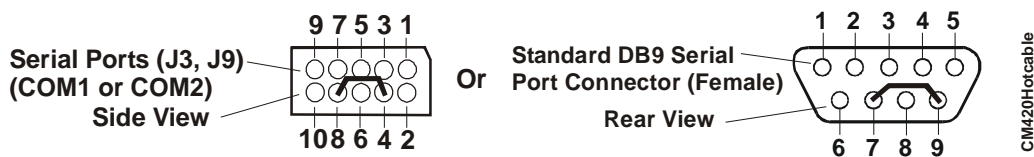

Figure 3-3. Hot Cable Jumper

Watchdog Timer

The watchdog timer (WDT) restarts the system if an error or mishap occurs, allowing the system to recover from the mishap, even though the error condition may still exist. Possible problems include failure to boot properly, loss of control by the application software, failure of an interface device, unexpected conditions on the bus, or other hardware or software malfunctions.

The WDT (watchdog timer) can be used both during the boot process and during normal system operation.

- During the Boot process – If the OS fails to boot in the time interval set in the BIOS, the system will reset.

Enable the *Watchdog Timer (sec)* field in the **BIOS and Hardware Settings** screen of BIOS Setup. Set the WDT for a time-out interval in seconds, between 1 and 255, in one second increments. Ensure you allow enough time for the operating system (OS) to boot. The OS or application must tickle (reset) the WDT before the timer expires. This can be done by accessing the hardware directly or through a BIOS call.

- During System Operation – An application can set up the WDT hardware through a BIOS call, or by accessing the hardware directly. Some Ampro Board Support Packages provide an API to the WDT. The application must tickle (reset) the WDT before the timer expires or the system will be reset. The BIOS implements interrupt 15 function 0x0C3h to manipulate the WDT.
- Watchdog Code examples – Ampro has provided source code examples on the CoreModule 420 Doc & SW CD-ROM illustrating how to control the WDT. The code examples can be easily copied to your development environment to compile and test the examples, or make any desired changes before compiling. Refer to the WDT Readme file in the Miscellaneous Source Code Examples subdirectory, under the Support Software menu on the CoreModule 420 Doc & SW CD-ROM.

Power Interface (J7)

The CoreModule 420 requires one +5 volt DC power source and uses a 10-pin header with 0.1" spacing. If the +5VDC power drops below ~4.65V, a low voltage reset is triggered, resetting the system.

The power input connector (J7) supplies the following voltages and ground directly to the module:

- 5.0VDC +/- 5% @ 1.35 Amps

Table 3-19 gives the signals for Power supply pin outs.

Table 3-19. Power Interface Pin/Signals (J7)

Pin	Signal	Descriptions
1	GND	Ground
2	+5V	+5 Volts
3	Key/GND	Key Pin on connector/Grounded on board
4	+12V	+12 volts routed to PC/104
5	GND	Ground
6	NC	Not connected
7	GND	Ground
8	+5V	+5 Volts
9	GND	Ground
10	+5V	+5 Volts

Note: The shaded area denotes power or ground.

Table 3-20. Power Interface Pin Arrangement (J7)

Pin #	Signal	Pin #	Signal
1	GND	2	+5V
3	GND	4	+12V
5	GND	6	Key/NC
7	GND	8	+5V
9	GND	10	+5V

Note: The shaded area denotes power or ground.

Introduction

This chapter describes the BIOS Setup menus and the various screens used for configuring the CoreModule 420. Some features in the Operating System (OS) or application software may require configuration in the BIOS Setup screens.

This section assumes the user is familiar with general BIOS setup and does not attempt to describe the BIOS functions. Refer to the appropriate PC reference manuals for information about the software interface of the onboard ROM BIOS. If Ampro has added to or modified the standard functions, these functions will be described.

The options provided for the CoreModule 420 are controlled by the BIOS Setup Utility. BIOS Setup is used to configure the CoreModule 420 features, modify the fields in the Setup screens, and save the results in the onboard configuration memory. Configuration memory consists of portions of the CMOS RAM in the battery-backed real time clock chip and the flash memory.

The Setup information is retrieved from configuration memory when the module is powered up or when it is rebooted. Changes made to the Setup parameters, with the exception of the time and date settings, do not take effect until the module is rebooted.

Setup is located in the ROM BIOS and can be accessed, when prompted using the key, while the module is in the Power On Self Test (POST) state, just before completing the boot process. The screen displays a message indicating when you can press .

The CoreModule 420 Setup is used to configure items in the BIOS using the following menus:

- BIOS and Hardware Settings
- Reload Initial Settings
- Load Factory Default Settings
- Exit, Saving Changes
- Exit, Discarding Changes

The main BIOS Setup menu offers the menu choices listed above and the related topics and screens are described on the following pages. Table 4-1 summarizes the list of BIOS menus and some of the features available for CoreModule 420.

Accessing BIOS Setup (VGA Display)

To access BIOS Setup using a VGA display for the CoreModule 420:

1. Turn on the VGA monitor and the power supply to the CoreModule 420.
2. Start Setup by pressing the [Del] key, when the following message appears on the boot screen.

```
Hit <Del> if you want to run SETUP
```

NOTE	If the setting for <i>Memory Test</i> is set to Fast, you may not see this prompt appear on screen if the monitor is too slow to display it on start up. If this happens, use the key early in the boot sequence to enter BIOS Setup.
-------------	---

3. Use the <Enter> key to access the screen menus listed in the BIOS opening screen.
4. Follow the instructions at the bottom of each screen to navigate through the selections and modify any settings.

Accessing BIOS Setup (Serial Console)

Entering the BIOS Setup, in serial console (console redirection) mode, is very similar to the steps you use to enter BIOS Setup with a VGA display input, except the actual keys you use.

1. Set the serial terminal, or the PC with communications software to the following settings:
 - ◆ 115k baud
 - ◆ 8 bits
 - ◆ One stop bit
 - ◆ No parity
 - ◆ No hardware handshake
2. Connect the serial terminal , or the PC with serial terminal emulation, to Serial Port 1 (J3) or Serial Port 2 (J9) of the CoreModule 420.
 - ◆ If the BIOS option, *Serial Console* is set to [Enable], use a standard null-modem serial cable.
 - ◆ If the BIOS option, *Serial Console* is set to [Hot Cable], use the modified serial cable described in Chapter 3, under *Hot (Serial) Cable*.
3. Turn on the serial terminal or the PC with serial terminal emulation and the power supply to the CoreModule 420.
4. Start Setup by pressing the Ctrl-C keys, when the following message appears on the boot screen.

Hit ^C if you want to run SETUP

5. Use the <Enter> key to access the Setup screen menus listed in the main BIOS screen.

NOTE The serial console port is not hardware protected but is removed from the COM table during BIOS Setup. Diagnostic software that probes hardware addresses may cause a loss or failure of the serial console functions.

Table 4-1. BIOS Setup Menus

BIOS Setup Menu	Item/Topic
BIOS and Hardware Settings	Date and Time Drive Configuration Boot Order and Drive and Boot Options Keyboard settings User Interface options Memory settings Power management Advanced Features On-Board Features (Serial, Parallel, USB, Video, etc.) PCI and Plug and Plug Options
Reload Initial Settings	Resets the BIOS (CMOS) to the last known settings
Load Factory Default Settings	Resets BIOS (CMOS) to factory settings
Exit, Saving Changes	Writes all changes to BIOS (CMOS) and exits
Exit, Discarding Changes	Closes BIOS without saving changes except time and date

Main BIOS Setup Menu

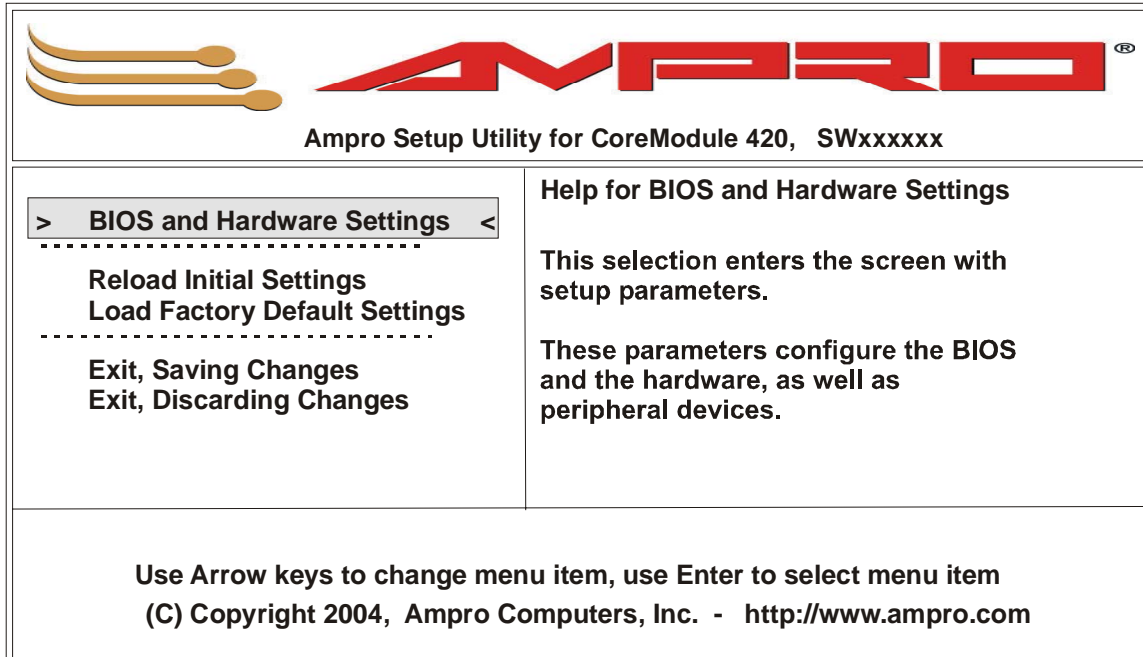

Figure 4-1. BIOS Setup Opening Screen

NOTE The default values or the typical settings are shown highlighted (**bold text**) in the list of options.

Refer to the bottom of the BIOS screens for the navigation instructions when making selections.

NOTE For the most current BIOS Information, refer to the CoreModule 420 Hardware Release Notes provided as hard copy in the shipping container.

BIOS Configuration Screen

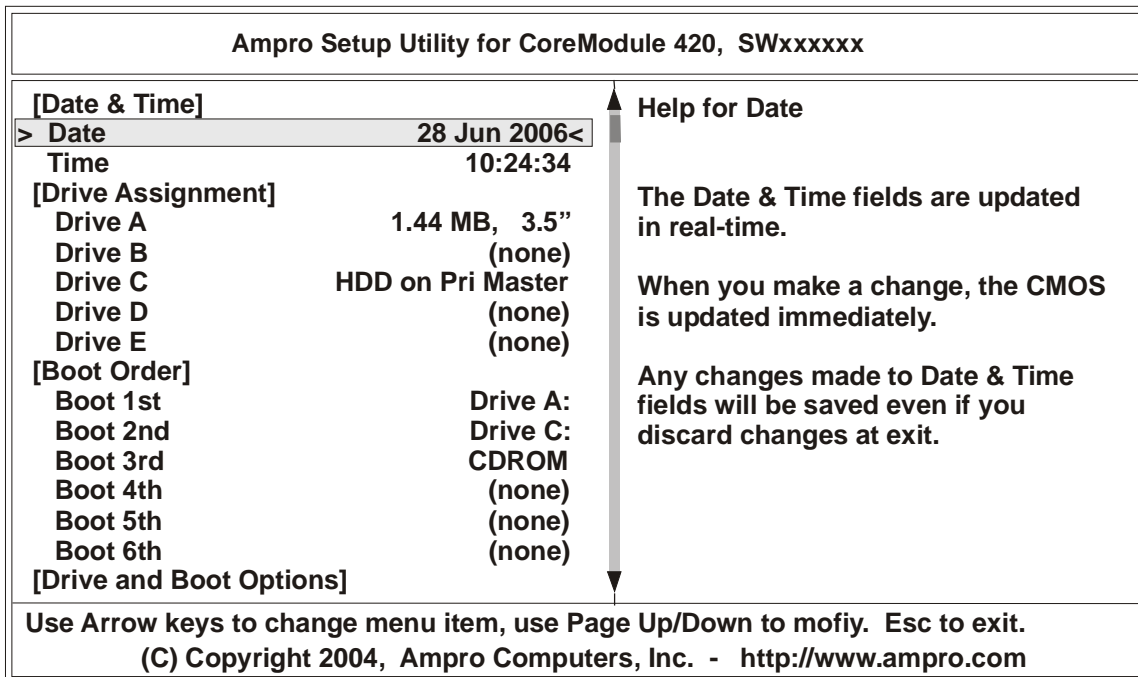

Figure 4-2. BIOS Configuration Screen

- **Date & Time**
 - ◆ DATE (dd:mmm:yyyy) – This feature sets the numeric entry of the day of the month, calendar month, and all 4 digits of the year, indicating the century plus year (28 Jun 2006).
 - ◆ Time (hh:mm:ss) – This feature sets the 24 hour clock, in hours, minutes, and seconds

Drive Configurations and Boot Options

- **Drive Assignment**
 - ◆ Drive A – [none], [360 kB, 5.25"], [1.2 MB, 5.25"], [720 kB, 3.5"], [**1.44 MB, 3.5"**], or [2.88 MB, 3.5"]
 - ◆ Drive B – [**none**], [360 kB, 5.25"], [1.2 MB, 5.25"], [720 kB, 3.5"], [1.44 MB, 3.5"], or [2.88 MB, 3.5"]
 - ◆ Drive C – [none], [**HDD on Pri Master**], [CDROM on Pri Master], [HDD on Pri Slave], [CDROM on Pri Slave], or [CF on Sec Master]
 - ◆ Drive D – [**none**], [HDD on Pri Master], [CDROM on Pri Master], [HDD on Pri Slave], [CDROM on Pri Slave], or [CF on Sec Master]
 - ◆ Drive E – [**none**], [HDD on Pri Master], [CDROM on Pri Master], [HDD on Pri Slave], [CDROM on Pri Slave], or [CF on Sec Master]

NOTE If a compact flash card is used to boot the system, it must be configured as [CF on Sec Master] on Drive C or D, but not Drive E, even though it appears under Drive E options.

The byte-wide socket or DiskOnChip (DOC) are not listed as a drive and are not in the boot order. Refer to the software instructions provided with your specific DiskOnChip device for more information concerning booting the device.

- **Boot Order**

- ◆ Boot 1st – [none], [**Drive A**], [Drive B], [Drive C], [Drive D], [CDROM], [Alarm], [Reboot], or [Flash]
- ◆ Boot 2nd – [none], [Drive A], [Drive B], [**Drive C**], [Drive D], [CDROM], [Alarm], [Reboot], or [Flash]
- ◆ Boot 3rd – [none], [Drive A], [Drive B], [Drive C], [Drive D], [**CDROM**], [Alarm], [Reboot], or [Flash]
- ◆ Boot 4th – [**none**], [Drive A], [Drive B], [Drive C], [Drive D], [CDROM], [Alarm], [Reboot], or [Flash]
- ◆ Boot 5th – [**none**], [Drive A], [Drive B], [Drive C], [Drive D], [CDROM], [Alarm], [Reboot], or [Flash]
- ◆ Boot 6th – [**none**], [Drive A], [Drive B], [Drive C], [Drive D], [CDROM], [Alarm], [Reboot], or [Flash]

NOTE

The default Boot order is, A, C, CD-ROM, and the BIOS will start its search for a bootable device in drive A, then C, then CD-ROM. If no bootable device is found, the screen will display “No Bootable Device Available” and the boot process will stop, allowing you to select from: R – for Reboot, or S – for Setup.

If you do not choose R or S, the boot process stops, until you intervene.

The Alarm or Reboot options can be used as the last boot order option, in cases where the BIOS can't boot from any of the selected drives. The Alarm option sounds beeps on the speaker.

- **Drive and Boot Options**

- ◆ Floppy over Parallel – [Disabled] or [**Enabled**]
 - * If [Enabled], this option selects the Floppy Drive instead of the Parallel port on the shared connector.
 - * If [Disabled], this option selects the Parallel port instead of the Floppy Drive on the shared connector.
- ◆ Floppy Swap – [**Disabled**] or [Enabled]
- ◆ Floppy Seek – [**Disabled**] or [Enabled]
- ◆ Hard disk Seek – [**Disabled**] or [Enabled]
- ◆ Boot Method – [**Boot Sector**] or [Windows CE]
- ◆ Compact Flash ATA mode – [**LBA**], [Physical], or [Phoenix]

This option allows you to select between the existing geometries when configuring the file system on your compact flash card.

NOTE

Always partition and format the compact flash card while attached to the CoreModule 420. This feature allows you to use any one of the three common geometries available for compact flash cards when configuring the file system on compact flash card while attached to the CoreModule 420. The LBA (Logical Block Address) is set as the default method because it can handle larger drives and is the newest method available. The other common methods that may be encountered are the Physical (below 512 MB) or Phoenix (physical above 512 MB).

User Interface Options

- **Keyboard and Mouse**

- ◆ Numlock – [**Disabled**] or [Enabled]
- ◆ Typematic – [Disabled] or [**Enabled**]

These fields are used to set parameters for the keyboard.

- Delay – [**250ms**], [500ms], [750ms], or [1000ms]

This field determines how many milliseconds the keyboard controller waits before stating to repeat a key, if the key is held down on the keyboard.

- Rate – [**30cps**], [24cps], [20cps], [15cps], [12cps], [10cps], [8cps], or [6cps]

This field determines the rate, in characters per second, the keyboard controller will repeat a key, if the key is held down on the keyboard.

- ◆ Initialize PS/2 Mouse – [Disabled] or [**Enabled**]

- **User Interface**

- ◆ Show ‘Hit ...’ – [Disabled] or [**Enabled**]

* If this feature is [Enabled], it will place ‘Hit ...’ on screen during the boot process, to indicate when you may select to enter the BIOS Setup menus.

- ◆ F1 Error Wait – [**Disabled**] or [Enabled]

* If this feature is [Enabled], it will display an Error message indicating when an error has occurred and waits for you to respond by hitting the F1 key.

- ◆ Config Box – [Disabled] or [**Enabled**]

* If this feature is [Enabled,] it displays the Configuration Summary Box, which list all of the configuration information for the system, at the completion of POST, but before the OS (Operating System) is loaded.

- ◆ Splash Screen – [**Disabled**] or [Enabled]

* If this feature is [Enabled] a Splash Screen is displayed as a default or customized splash screen. Refer to the Splash Screen Customization topic later in this chapter for instructions on how to customize the splash screen.

Memory Control Options

- **Memory**

- ◆ Memory Test – [**Fast**], [Standard], or [Exhaustive]
- ◆ Memory Hole – [**Disabled**], [1MB], [2MB], [4MB] or [8MB]
- ◆ Flash Address – [**Disabled**], [8MB], [9MB], [10MB], [11MB], [12MB], [13MB], [14MB] or [15MB]
- ◆ Shadow C800-CBFF – [**Disabled**] or [Enabled]
- ◆ Shadow CC00-CFFF – [**Disabled**] or [Enabled]
- ◆ Shadow D000-D3FF – [**Disabled**] or [Enabled]
- ◆ Shadow D400-D7FF – [**Disabled**] or [Enabled]
- ◆ Shadow D800-DBFF – [**Disabled**] or [Enabled]
- ◆ Shadow DC00-DFFF – [**Disabled**] or [Enabled]

Power Management and Advanced User Options

- **Power Management**
 - ◆ APM – **[Disabled]** or [Enabled]
- **Advanced features**
 - ◆ Post Memory Manager – **[Disabled]** or [Enabled]
 - ◆ Watchdog Timeout (sec) – [select whole number between 1 and 255 seconds] or **[Disabled]**
 - * If this feature is enabled by selecting a timer interval, it will direct the watchdog timer to reset the system if the OS fails to boot the system within the timer interval specified.
 - ◆ Serial Console – **[Hot Cable]** or [Enabled]
 - * If the Hot Cable option is selected, the BIOS only allows serial console (console redirection) when a Hot Cable is actually connected to Serial 1 or 2 (COM 1 or 2). The Hot Cable option can not be used on Serial 3 or 4 (COM 3 or 4). Use the modified serial cable described in Chapter 3, under *Hot (Serial) Cable*.
 - * If the [Enabled] option is selected, it instructs the BIOS to operate in the serial console (console redirection) mode at all times (no video locally) with the serial port selected in the Serial Console > Port field listed below. This option can be used on any of the Serial ports (Serial 1, 2, 3, or 4). Use a standard null-modem serial cable.
 - * If a Hot Cable is connected to the other port (port not selected) the Hot Cable will override the settings in this field [Enabled] and the Serial Console > Port field.
 - Port – **[3F8h]**, [2F8h], [3E8h], or [2E8h]

This field selects the COM (Serial) port address used for console redirection when [Enabled] has been selected in Serial Console. Use a standard null-modem serial cable.

 - * If you connect a Hot Cable to the other port (port not selected) this field setting is overridden and activates the connected port. Use the modified serial cable described in Chapter 3, under *Hot (Serial) Cable*.
- **On-Board Serial Ports**
 - ◆ Serial 1 Mode – **[RS-232]** or [RS-485]
 - ◆ Serial 2 Mode – **[RS-232]** or [RS-485]
 - ◆ Serial 3 – [Disabled], [3F8h], [2F8h], **[3E8h]**, [2E8h], [260h], [2F0h], [3E0h], [2E0h], [200h], or [220h]
 - IRQ – [none], [1], [3], [4], [5], [6], [7], [8], [9], **[10]**, [11], or [12]
 - ◆ Serial 4 – [Disabled], [3F8h], [2F8h], [3E8h], **[2E8h]**, [260h], [2F0h], [3E0h], [2E0h], [200h], or [220h]
 - IRQ – [none], [1], [3], [4], [5], [6], [7], [8], **[9]**, [10], [11], or [12]
- **On-Board LPT Port**

If the Floppy Drive is selected instead of the Parallel port, these settings have no effect.

 - ◆ LPT 1 – [Disabled], **[378h]**, [278h], [3BCh], [370h], or [270h]
 - IRQ – [none], [1], [3], [4], [5], [6], **[7]**, [8], [9], [10], [11], or [12]
 - DMA – **[3]**, [2], [1], or [0]
 - Mode – **[Standard]**, [SPP (bi-dir)], [EPP 1.7 + SPP], [EPP 1.9 + SPP], [EPP 1.7 + ECP], [EPP 1.9 + ECP], or [ECP]

Video and On Board Controller Options

- **On-Board Video**

- ◆ Framebuffer Size – [Disabled], [1MB], [2MB], [3MB], or [**4MB**]

This field specifies the amount of system memory used for the on-board Video Framebuffer. The amount of memory used for the Framebuffer of the on-board Video controller is subtracted from the available system memory.

NOTE If the Framebuffer Size field is set to [Disabled], then no video will be displayed on screen.

- ◆ VGA Palette Snoop – [**Disabled**] or [Enabled]

- **On-Board Controllers**

- ◆ Primary IDE – [Disabled] or [**Enabled**]
- ◆ Secondary IDE – [Disabled] or [**Enabled**]
- ◆ PS/2 Mouse IRQ – [none], [1], [3], [4], [5], [6], [7], [8], [9], [10], [11], or [**12**]
- ◆ USB IRQ – [none], [1], [3], [4], [5], [6], [7], [9], [10], [**11**], [12], [14], or [15]
- ◆ Ethernet IRQ – [none], [1], [3], [4], [**5**], [6], [7], [9], [10], [11], [12], [14], or [15]
- ◆ ISA Speed – [7.16 MHz] or [**8.25 MHz**]

- **CPU**

- ◆ L1 Cache – [Disabled], [**Write-Back**], or [Write-Through]
- ◆ No Lock Cycles – [Disabled] or [**Enabled**]

PCI, Plug n' Play, and Interrupt/DMA Assignments

- Plug and Play

- ◆ PnP BIOS – [Disabled] or [**Enabled**]
 - * If this field is set to [Enabled], the BIOS uses Plug and Play adapter initialization and assigns the resources, such as I/O addresses, IRQs, and DMA channels to Plug and Play compatible devices. The resources assigned by the BIOS are based on the settings of the IRQ and DMA channel assignments listed in the following fields.
 - * If this field is set to [Disabled], the IRQs and DMA channels listed below can not be assigned to Plug and Play devices.
- ◆ PnP OS – [Disabled] or [**Enabled**]
 - * If this field is set to [Enabled], the BIOS makes the Plug and Play API available for Plug and Play Operating Systems. This allows the Plug and Play OS to get the Plug and Play information by calling the Plug and Play API.
- ◆ Assign IRQ 1 – [**Disabled**] or [Enabled]
 - * If this field is set to [Enabled], then the BIOS can assign this IRQ to a Plug and Play adapter.
 - * If another device in the system is using this IRQ, then this field should be set to [Disabled].
- ◆ Assign IRQ 3 – [Disabled] or [**Enabled**] (Typically COM2)
 - * If this field is set to [Enabled], then the BIOS can assign this IRQ to a Plug and Play adapter.
 - * If another device in the system is using this IRQ, then this field should be set to [Disabled].

- ◆ Assign IRQ 4 – [Disabled] or **[Enabled]** (Typically COM1)
 - * If this field is set to [Enabled], then the BIOS can assign this IRQ to a Plug and Play adapter.
 - * If another device in the system is using this IRQ, then this field should be set to [Disabled].
- ◆ Assign IRQ 5 – [Disabled] or **[Enabled]**
 - * If this field is set to [Enabled], then the BIOS can assign this IRQ to a Plug and Play adapter.
 - * If another device in the system is using this IRQ, then this field should be set to [Disabled].
- ◆ Assign IRQ 6 – **[Disabled]** or [Enabled] (Typically Floppy Disk)
 - * If this field is set to [Enabled], then the BIOS can assign this IRQ to a Plug and Play adapter.
 - * If another device in the system is using this IRQ, then this field should be set to [Disabled].
- ◆ Assign IRQ 7 – [Disabled] or **[Enabled]** (Typically LPT1)
 - * If this field is set to [Enabled], then the BIOS can assign this IRQ to a Plug and Play adapter.
 - * If another device in the system is using this IRQ, then this field should be set to [Disabled].
- ◆ Assign IRQ 9 – [Disabled] or **[Enabled]** (Typically unused)
 - * If this field is set to [Enabled], then the BIOS can assign this IRQ to a Plug and Play adapter.
 - * If another device in the system is using this IRQ, then this field should be set to [Disabled].
- ◆ Assign IRQ 10 – [Disabled] or **[Enabled]** (Typically unused)
 - * If this field is set to [Enabled], then the BIOS can assign this IRQ to a Plug and Play adapter.
 - * If another device in the system is using this IRQ, then this field should be set to [Disabled].
- ◆ Assign IRQ 11 – [Disabled] or **[Enabled]** (Typically ISA Bridge/Native IDE)
 - * If this field is set to [Enabled], then the BIOS can assign this IRQ to a Plug and Play adapter.
 - * If another device in the system is using this IRQ, then this field should be set to [Disabled].
- ◆ Assign IRQ 12 – **[Disabled]** or [Enabled] (Typically PS/2 Mouse)
 - * If this field is set to [Enabled], then the BIOS can assign this IRQ to a Plug and Play adapter.
 - * If another device in the system is using this IRQ, then this field should be set to [Disabled].
- ◆ Assign IRQ 14 – **[Disabled]** or [Enabled] (Typically Primary IDE controller)
 - * If this field is set to [Enabled], then the BIOS can assign this IRQ to a Plug and Play adapter.
 - * If another device in the system is using this IRQ, then this field should be set to [Disabled].
- ◆ Assign IRQ 15 – **[Disabled]** or [Enabled] (Typically Secondary IDE controller)
 - * If this field is set to [Enabled], then the BIOS can assign this IRQ to a Plug and Play adapter.
 - * If another device in the system is using this IRQ, then this field should be set to [Disabled].
- ◆ Assign DMA 0 – **[Disabled]** or [Enabled]
 - * If this field is set to [Enabled], then the BIOS can assign this DMA channel to a Plug and Play adapter.
 - * If another device in the system is using this DMA channel, then this field should be set to [Disabled].
- ◆ Assign DMA 1 – **[Disabled]** or [Enabled]
 - * If this field is set to [Enabled], then the BIOS can assign this DMA channel to a Plug and Play adapter.
 - * If another device in the system is using this DMA channel, then this field should be set to [Disabled].

- ◆ Assign DMA 2 – [**Disabled**] or [Enabled]
 - * If this field is set to [Enabled], then the BIOS can assign this DMA channel to a Plug and Play adapter.
 - * If another device in the system is using this DMA channel, then this field should be set to [Disabled].
- ◆ Assign DMA 3 – [Disabled] or [**Enabled**]
 - * If this field is set to [Enabled], then the BIOS can assign this DMA channel to a Plug and Play adapter.
 - * If another device in the system is using this DMA channel, then this field should be set to [Disabled].
- ◆ Assign DMA 5 – [Disabled] or [**Enabled**]
 - * If this field is set to [Enabled], then the BIOS can assign this DMA channel to a Plug and Play adapter.
 - * If another device in the system is using this DMA channel, then this field should be set to [Disabled].
- ◆ Assign DMA 6 – [Disabled] or [**Enabled**]
 - * If this field is set to [Enabled], then the BIOS can assign this DMA channel to a Plug and Play adapter.
 - * If another device in the system is using this DMA channel, then this field should be set to [Disabled].
- ◆ Assign DMA 7 – [Disabled] or [**Enabled**]
 - * If this field is set to [Enabled], then the BIOS can assign this DMA channel to a Plug and Play adapter.
 - * If another device in the system is using this DMA channel, then this field should be set to [Disabled].

Splash Screen Customization

The CoreModule 420 BIOS supports a graphical splash screen, which can be customized by the user and displayed on screen when enabled through the BIOS Setup Utility. The graphical image can be a company logo or any custom image the user wants to display during the boot process. The custom image can be displayed as the first image displayed on screen during the boot process and remain there, depending on the options selected in BIOS Setup, while the OS boots.

Splash Screen Image Requirements

The user's image may be customized with any bitmap software editing tool, but must be converted into an acceptable format with the tools (files and utilities) provided by Ampro. If the custom image is not converted with the tools provided, then the image will not display properly when this feature is selected in BIOS Setup.

NOTE	Do not use other splash screen conversion tools, including tools from other Ampro products, as these will render an image that is not compatible with the CoreModule 420 BIOS.
-------------	--

The splash screen image supported by the CoreModule 420 BIOS should be:

- Bitmap image
- Exactly 640x480 pixels
- Exactly 16 colors
- A converted file size of not greater than 5 kbytes compressed (see example splash.rie file)

Converting the Splash Screen File

The following files are provided by Ampro on the CoreModule 420 Doc & SW CD-ROM and are required for converting a custom splash screen file. Refer to the Miscellaneous Source Code Examples subdirectory under the Support Software directory on the CD-ROM for the utilities and examples of how to load a customized image in the *CD-ROM\Software\Misc\Splash* directory.

- splash.bmp
- resplash.com
- convert.exe
- cm420.bin
- convert.idf

The process of converting and loading a custom image onto the CoreModule 420 involves the following sequence of events:

- Prepare directory for conversion (create directory and copy the files into it)
- Obtain the CoreModule 420 BIOS binary
- Prepare the custom image file
- Convert the image to an acceptable BIOS format
- Merge the image with BIOS binary to create new BIOS binary
- Load the new BIOS binary onto the CoreModule 420 board

NOTE	You can use any Windows PC to convert the custom image, but your PC must have an internet browser to access, view, and make selections in the main menu of the CoreModule 420 Doc & SW CD-ROM. For example: Microsoft Internet Explorer 4.x, or greater, Netscape Navigator version 4.x, or greater, or the equivalent.
-------------	---

Use the following steps to convert and load your custom image onto the CoreModule 420.

1. Copy the files from the *CD-ROM\Software\Misc\Splash* directory on the CD-ROM to a new directory (conversion directory) on your PC.

This new conversion directory is where you intend to do the conversion and save the file.

2. Ensure you remove the read-only attributes from all the files as part of the file copying process.
3. Copy the CoreModule 420 BIOS binary file (cm420.bin) to the new conversion directory on your PC where the other files and utilities are located.

If file is not on the CoreModule 420 Doc & SW CD-ROM, you will have to obtain it from Ampro.

NOTE

Ampro recommends keeping a copy of this original cm420.bin file, just in case you encounter problems with your new file or have difficulty updating the BIOS with the new image.

4. Prepare your custom image file with any Windows bitmap software editing tool.
 - ◆ For example, Corel Photo-Paint, Adobe Photoshop, or the Windows Paint program provided with Windows. You can insert a desired graphic image, logo, text, etc. into the file.
 - ◆ The custom image must be a bitmap image in .bmp format at 640x480 pixels and it must be 16 colors. The file should be about 150 kbytes uncompressed. Refer to the example file splash.bmp.
5. Save your custom image file as splash.bmp at 640x480 pixels by 16 colors.
 - ◆ If your custom image file is not approximately 150 kbytes in size it is probably not in the right format or is too complex to be used in the BIOS. You will have to edit it down in size until you have reached an acceptable file size. Refer to the example splash.bmp.
 - ◆ If you are doubtful about the conversion process, due to the file size, Ampro recommends making a copy of your new splash.bmp, so that you can edit it later if the conversion does not yield a small enough file. Otherwise, you may have to re-create your custom image before you can edit it down to an acceptable file size.
6. If your custom image file is not on the conversion PC, copy the new splash.bmp file to the conversion directory.
7. Run the following command from DOS, or a Windows DOS pop-up screen to convert your new splash.bmp file.

```
C:\splash>convert convert.idf
```

This conversion should yield a *splash.rle* file of approximately 5kbytes in size or less, depending on the complexity of your image.

8. If the splash.rle file size is greater than 5kbytes, go back to the unconverted image file and edit the file.

You may reduce the file size of the converted image (splash.rle) by reducing the image's complexity.

9. Run the following command to merge the converted image with the BIOS binary file.

```
C:\splash>resplash cm420.bin splash.rle cm420n.bin
```

This creates a new BIOS named cm420n.bin, which has the new splash image. Rename the new BIOS file cm420n.bin to cm420.bin before using it to update the CoreModule 420.

10. Copy the files update.bat, aflash.exe, and the renamed cm420.bin to a DOS boot floppy.
11. Boot the CoreModule 420 from the floppy and run update.bat.
12. Cycle the power to the CoreModule 420 and enter BIOS Setup to enable the splash screen.

On-Board Flash Access and Use

This section describes how to use the on-board flash memory and load an application in the available lower 768 kB region of the 1 MB of flash memory. The application can boot directly from the on-board flash memory.

The flash memory can be accessed at 128 MB intervals above the base address (with the exception of 256 MB). For example, if the flash address is set to 8 MB, then the flash memory can be accessed at 136 MB, 392 MB, 520 MB etc.

CAUTION To prevent a system crash or unusable BIOS, do not overwrite the BIOS. The entire 1 MB of flash is accessible, but only the lower 768 kB region is available for custom applications. The higher 256 kB region is used for the BIOS and can be overwritten, rendering the CoreModule 420 unbootable!!

Flash Programming Requirements

To build an example application under DOS or in a Windows DOS pop-up screen, you need to have one of the following tools.

- Microsoft Visual C++ 7.0 – This is a commercial product and is available from Microsoft. It can be downloaded as part of the .NET Framework from <http://msdn.microsoft.com>. The compiler is part of the Microsoft .NET Framework V1.1 Software Development Kit and the NET Framework Redistributable Package V1.1. Both of these need to be downloaded and installed.
- Open Watcom C/C++32 1.1 – This is a commercial compiler product available from <http://www.openwatcom.org>. It is also included on the *CoreModule 420 Doc & SW CD-ROM* in the *CD-ROM\Software\Misc\F\ash\Watcom* directory.
- Other versions of the above tools may also work.

The following example application is also necessary and is provided by Ampro.

- Example application – This application can be found in the *CD-ROM\Software\Misc\F\ash\Watcom* or *CD-ROM\Software\Misc\F\ash\Msvc* directory for the Watcom compiler or Visual C++ compiler respectively. This example application will be described in more detail in the following procedures.

Building the Example

Ampro provides an example for flash programming found on the *CoreModule 420 Doc & SW CD-ROM* under *Miscellaneous Source Code Examples* in the *Support Software* directory. The example actually consists of two parts:

- Example application – The example application shows how a C++ compiler can be used to generate a 32-bit application, which runs without an Operating System. First, build this application using the *make.bat* file. The *make.bat* file will build *app.exe*.
- Bootloader – The bootloader can be found in *bootsec.asm* and the final Flash image is built with *image.asm*. You can use *make.bat* to build the bootloader and Flash image (in the *CD-ROM\Software\Misc\F\ash*).

Example Assumptions

The following assumptions have been made concerning the application and certain functionality has not implemented.

- The application is located at the fixed address of 1 MB.
- The bootloader has to load the application at the fixed address of 1 MB.
- The startup code is incomplete.

For example, early initialization functions and constructors normally called before *main*, are not called at all.

- In general, the standard libraries can NOT be used.
- C++ exception handling is not supported.
- The bootloader makes certain assumptions, which are documented in the source code.

Installing the Example Application

To install the example application, the generated Flash image needs to be programmed into Flash memory.

1. Copy the files *aflash.exe*, *image* and *upding.bat* to a floppy.
2. Turn on power to the CoreModule 420 and enter BIOS Setup.
3. Go to Memory settings under the *BIOS and Hardware Settings* screen and set **Flash Address** to [8MB].
4. Select *Esc* to exit to the main menu.
5. Exit BIOS Setup using the *Exit, Saving Changes* option.
6. Reboot the CoreModule 420 from a MS-DOS 6.22 floppy diskette, without a *config.sys* and *autoexec.bat* and then remove the diskette.
7. Insert the floppy diskette into the drive with *aflash.exe*, *image* and *upding.bat* previously copied to it.
8. Change the current directory to the floppy, by typing **a:**
9. Run the *upding.bat* file from the diskette.

This bat file will program the file *image* into the Flash memory.

10. Reboot the CoreModule 420 and enter BIOS Setup again.
11. Go to the *BIOS and Hardware Settings*, set **Boot 1st** to [Flash] to boot from Flash.
12. Select *Esc* to exit to the main menu.
13. Exit BIOS Setup using the *Exit, Saving Changes* option.
14. After system reboots from the Flash, the example application sends a message to the screen.

Flash Boot API

The BIOS implements an API call to assist in booting from Flash. This API allows bootloaders to call the BIOS to copy memory anywhere in the 32-bit address range. All addresses are treated as linear, physical addresses.

Refer to the Flash directory under *Miscellaneous Source Code Examples* on the CoreModule 420 Doc & SW CD-ROM (*CD-ROM\Software\Misc\Flash*) for the examples and more information.

Ampro Computers, Inc. provides a number of methods for contacting Technical Support listed below in Table A-1. Requests for support through the Virtual Technician are given the highest priority, and usually will be addressed within one working day.

- Ampro Virtual Technician – This is a comprehensive support center designed to meet all your technical needs. This service is free and available 24 hours a day through the Ampro web site at <http://ampro.custhelp.com>. This includes a searchable database of Frequently Asked Questions, which will help you with the common information requested by most customers. This is a good source of information to look at first for your technical solutions. However, you must register online before you can login in to access this service.
- Personal Assistance – You may also request personal assistance by going to the "Ask a Question" area in the Virtual Technician. Requests can be submitted 24 hours a day, 7 days a week. You will receive immediate confirmation that your request has been entered. Once you have submitted your request you can go to the "My Stuff" area and log in to check status, update your request, and access other features.
- Embedded Design Resource Center – This service is also free and available 24 hours a day at the Ampro web site at <http://www.ampro.com>. However, you must be registered online before you can login in to access this service.

The Embedded Design Resource Center was created as a resource for embedded system developers to share Ampro's knowledge, insight, and expertise gained from years of experience. This page contains links to White Papers, Specifications, and additional technical information.

Table A-1. Technical Support Contact Information

Method	Contact Information
Virtual Technician	http://ampro.custhelp.com
Web Site	http://www.ampro.com
Standard Mail	Ampro Computers, Incorporated 5215 Hellyer Avenue San Jose, CA 95138-1007, USA

Appendix B

Connector Part Numbers

Table B-1 provides the non-standard RoHS connectors, including the manufacturers and part numbers, used on the CoreModule 420. These part numbers can be used to determine the mating connectors, when making your own cables.

Table B-1. Connector and Manufacture's Part Numbers

Connector	Pin Number/Pin Spacing/ Orientation	Manufacturer	Manufacturer's PN
J2 – Ethernet	8-pin, 0.1", right angle	AMP/Tyco	3-647079-8
J3 – Serial 1, J5 – Utility, J7 – Power, J9 – Serial 2	10-pin, 0.1", right angle	TEKA	ZR205A1CC-NS-00 ZR205A1BC-NS-00
J4 – Floppy/ Parallel	26-pin, 0.1", right angle	TEKA	ZR213A1BC-NS-00 ZR213A1CC-NS-00
J6 – IDE	44-pin, 2 mm, straight	TEKA	HM222CB1N-191-00 HM222CC1N-191-00
J8 – GPIO,	10-pin, 2 mm, straight	TEKA	HM205CB1N-191-00 HM205CC1N-191-00
J10 – USB	5-pin, 0.140", right angle	Tyco	3-641216-5
J11 – Video	44-pin, 2 mm, right angle	Adam Tech or Samtec	2PH2R44SGAHT TMM-122-01-SM-D-RA
J13 – Serial 3, J14 – Serial 4	10-pin, 0.1", straight	Molex	15-91-3100

Note: The following list provides the Manufacturer abbreviations used in this table and the web sites where you can locate the required mating connector information.

- Adam Tech = Adam Technologies at <http://www.adam-tech.com>
- Samtec = Samtec, Inc. at <http://www.samtec.com>
- Molex = Molex Inc. at <http://www.molex.com>
- TEKA = Teka Interconnection Systems at <http://www.tekais.com>
- Tyco = Tyco Electronics Corp at <http://www.tycoelectronics.com>

Index

Ampro Products		
CoreModule™ 410	2	
CoreModule™ 600	2	
CoreModule™ 800	2	
ETX Family	3	
LittleBoard™ Family	3	
MightyBoard™ Family	3	
MiniModule™ Family	3	
ReadyBoard™ Family	3	
ReadyPanel™ Family	3	
ReadySystem™ Family	4	
Battery		
connector pin outs	36	
external Lithium type	41	
function.....	36, 41	
BIOS recovery		
Description	42	
<i>See also</i> Oops! jumper		
BIOS Setup		
accessing BIOS Setup (VGA)	47	
accessing console redirection	48	
accessing serial console.....	48	
Advanced user settings	53	
boot order settings	51	
Compact Flash	50	
compact flash format NOTE.....	51	
compact flash format selection	51	
console redirection	42	
console redirection settings	53	
CoreModule 420 Hardware Release Notes.....	49	
CPU settings	54	
default settings.....	49	
DMA settings	55	
drive assignments	50	
Enable BIOS prompt	52	
Enable Config Box	52	
enter BIOS prompt not seen	47	
Ethernet settings	54	
Flash settings	51	
floppy drive selections.....	50, 51	
Hot (Serial) Cable.....	42	
Hot Cable.....	53	
IDE port settings.....	54	
IRQ settings.....	54	
keyboard settings.....	52	
memory settings	52	
mouse settings	52, 54	
no bootable device available.....	51	
on-board controller settings	54	
parallel (LPT1) port settings.....	51, 53	
PC/104 clock speeds.....	54	
Plug and Play settings.....	54	
Power Management settings.....	53	
PS/2 mouse initialization.....	52	
PS/2 mouse settings.....	54	
serial console settings.....	53	
serial port settings	53	
serial terminal.....	42	
special boot options.....	51	
Splash Screen selection.....	52	
setting time, month, day, year	50	
USB settings.....	54	
user interface options	52	
video port settings	54	
watchdog timer (WDT) settings.....	43, 53	
boot device		
alarm option	51	
CD-ROM	50	
compact flash	50	
DiskOnChip (DOC) not listed.....	50	
floppy disk drive	50, 51	
floppy drive selection.....	51	
no bootable device available	51	
reboot option	51	
boot order		
BIOS Setup	51	
Bytewise socket		
BIOS recovery, external.....	18	
DiskOnChip	18	
external BIOS.....	18, 50	
not listed in BIOS Setup.....	50	
CAUTION		
overwriting BIOS settings.....	59	
master/slave GPIO pins.....	41	
Compact Flash		
always use [CF on Sec Master].....	50	
ATA format selection.....	51	
BIOS Setup	50	
Card – IDE drive equivalent	29	
format NOTE	51	
socket accepts Type I or II	29	
Connectors		
connector list	11	
connector locations	11	
manufacturer's number	63	
parts list.....	63	
Console Redirection		
accessing BIOS Setup	48	
features	42	
serial console.....	42	
serial port settings	48, 53	
setting up serial terminal	48	
<i>See also</i> serial console		
CoreModule 420		
1 MB flash memory	18	
64 MB SDRAM memory	18	
BIOS Setup	47	
block diagram.....	9	
bytewise socket (U5)	18	
compact flash selection	50	

compact flash socket.....	29	dimensions	14
connector locations	11	DiskOnChip (DOC)	50
connector part numbers	63	DMA map	20
CPU features.....	6, 18	Enter BIOS prompt not seen	47
current capability	44	Environmental specifications	15
dimensions	14	Ethernet	
DiskOnChip (DOC) settings.....	50	connector	37
DMA map.....	20	controller	37
drive assignments	50	Port LEDs.....	12
environmental requirements	15	port settings	54
Ethernet connector	37	supported feature	37
Ethernet features	37	Flash Access	
Ethernet LEDs	12	API call	60
features	6	BIOS settings	51
flash memory access.....	59	example application	60
floppy disk port.....	31	flash programming	59
floppy port connector.....	31	installing example application.....	60
GPIO features	41	programming tools	59
GPIO master/slave pins	41	two methods	59
heatsink requirements	15	floppy disk port	
height limitations	15	drive selection	51
I/O address map	20	drive settings	50
IDE features.....	27	supported drive sizes	31, 50
Jumper settings	12	Hardware Release Notes	
low voltage limit.....	44	latest BIOS setup information	49
major integrated circuits (chips)	10	Hot Cable	
mechanical dimensions.....	14	BIOS settings	53
memory features	18	console redirection	42
Oops! jumper.....	42	modified serial cable	42
parallel (LPT1) port connector	31	serial console.....	42
PC/104 architecture	5	I/O address map.....	20
pin-1 locations	10	IDE interface	
power requirements	15	port settings	54
product description	6	supported feature	27
QuickStart Kit.....	2	Integrated Circuit (chip) specifications	
Real Time Clock (RTC)	41	web sites	1
RS-485 mode	34	Interrupt (IRQs) list.....	20
Serial connectors.....	34	Jumpers	
serial console	42	locations	12
serial port features	33	settings	12
single board computer (SBC)	5	Keyboard	
Splash Screen.....	52	connector pin outs	36
USB connector.....	35	supported feature	36
Utility connector	36	LEDs	
video port connector	39	Ethernet Port	12
video port features	38	Lithium Battery	
voltage requirements.....	44	real time clock (RTC).....	41
watchdog timer (WDT)	43	low voltage limit	44
weight	14	major chip specifications	
<i>see also</i> BIOS Setup		web sites	1
<i>see also</i> supported features		Memory features	
CPU		1 MB flash memory	18
heatsink requirements	15	64 MB SDRAM	18
settings.....	54	BIOS settings	52
STPC Atlas features.....	18	Byte-wide socket	18
default settings		Mouse	
BIOS Setup.....	49	connector pin outs	36
shown in bold text.....	49	supported feature	36

-
- no bootable device available 51
 - null modem serial cable 42, 53
 - Oops! jumper
 - DB9 connector 42
 - Serial port 1 42
 - Parallel (LPT1) port
 - features 31
 - settings 53
 - supported protocols 31, 53
 - Parallel/Floppy interface
 - shared port 31
 - PC/104 (ISA) bus
 - architecture 5
 - connector 22
 - clock speeds up to 8.25 MHz 22, 54
 - Pin-1 locations 10
 - POST
 - no bootable device available 51
 - power interface connector (J7)
 - pinouts 44
 - Power Management
 - BIOS settings 53
 - power requirements 15
 - QuickStart Kit
 - contents 2
 - CoreModule 420 2
 - Real Time Clock (RTC) 41
 - reference material
 - PC/104 specifications 1
 - web sites 1
 - Reset Switch
 - connector pin outs 36
 - supported feature 36
 - Serial Console
 - accessing BIOS Setup 48
 - console redirection 42
 - Hot cable 42
 - modified serial cable 42
 - serial port settings 48, 53
 - serial port setup 48
 - serial terminal 42
 - setting up serial terminal 48
 - standard null modem serial cable 42, 53
 - terminal emulation software 42
 - two methods 42
 - See also* console redirection
 - Serial Ports
 - BIOS settings 53
 - connector pin outs 34
 - features 33
 - RS-232/RS-485 support 33
 - Serial terminal
 - ANSI-compatible 42
 - Speaker
 - connector pin outs 36
 - supported feature 36
 - Splash Screen
 - converting image 57
 - customization 57
 - customer defined 57
 - image conversion tools 58
 - requirements 57
 - standard null modem serial cable
 - serial console 42, 53
 - supported features
 - 1 MB flash memory 6, 18
 - 32-pin bytewise socket 6
 - 64 MB SDRAM 18
 - 768 kB OEM memory use 6
 - battery-free boot 8
 - BIOS recovery (Oops! jumper) 8, 42
 - BIOS Setup Utility 47, 48
 - bytewise socket (U5) 18
 - compact flash card socket 29
 - compact flash socket (1) 7
 - connector list 11
 - console redirection 8, 42, 53
 - DMA map 20
 - Ethernet port (1) 7, 37
 - Ethernet port LEDs 12
 - external lithium battery 7, 36
 - external speaker 36
 - flash access 59
 - flash memory 59
 - floppy disk drives (2) 7, 31
 - floppy disk port selection 50
 - GPIO interface 8
 - Hot Cable 42, 53
 - I/O address map 20
 - IDE devices (3) 27
 - IDE drives (2) 6
 - IDE interface 6, 27
 - Interrupt (IRQs) list 20
 - jumpers, on board 12
 - keyboard (1) 7, 36
 - major integrated circuits (chips) 10
 - mechanical dimensions 14
 - memory 6, 18
 - memory map 18
 - mouse 36
 - Oops! jumper (BIOS recovery) 8, 42
 - parallel (LPT1) port (1) 7, 31, 53
 - PC/104 bus interface 6, 22
 - power requirements 15
 - PS/2 mouse (1) 7
 - real time clock (RTC) 8, 41
 - reset switch 36
 - RS-232/RS-485 selection 33
 - serial console 8, 42, 53
 - serial ports (4) 7, 33, 53
 - shared floppy/parallel interface 31
 - Splash Screen customization 8, 52, 57
 - STPC Atlas CPU 6, 18
 - USB interface (1) 7, 35
 - USB over current fuse 35
 - user GPIO signals 41

Index

Utility connector.....	36	keyboard connection	36
video setting, onboard.....	54	mouse connection.....	36
video (CRT) interface.....	38	reset switch connection	36
video (CRT) interface (1)	8, 38	Video port	
video (LCD) interface (1)	8, 38	controller features.....	38
video port interface (1)	8, 38	settings	54
watchdog timer (WDT)	8, 43, 53	Watchdog Timer (WDT)	
terminal emulation software		1 to 255 settings	43
serial console	42	BIOS settings	53
thermal cooling		description.....	43
heatsinks	15	source code examples.....	43
USB interface		web sites	
connector pin outs.....	35	integrated circuit (chip) specifications	1
port features	35	major chip specifications.....	1
port settings	54	PC/104 specifications.....	1
Utility Connector		reference material.....	1
battery connection.....	36	weight.....	14
external speaker connection.....	36		

