



ReadySystemTM Linux Users Guide

P/N 5001776A Revision B

Notice Page

NOTICE

No part of this document may be reproduced, transmitted, transcribed, stored in a retrieval system, or translated into any language or computer language, in any form or by any means, electronic, mechanical, magnetic, optical, chemical, manual, or otherwise, without the prior written permission of Ampro Computers, Incorporated.

DISCLAIMER

Ampro Computers, Incorporated makes no representations or warranties with respect to the contents of this manual or of the associated Ampro products, and specifically disclaims any implied warranties of merchantability or fitness for any particular purpose. Ampro shall under no circumstances be liable for incidental or consequential damages or related expenses resulting from the use of this product, even if it has been notified of the possibility of such damages. Ampro reserves the right to revise this publication from time to time without obligation to notify any person of such revisions. If errors are found, please contact Ampro at the address listed below on the Notice page of this document.

TRADEMARKS

Ampro and the Ampro logo are registered trademarks, and CoreModule, EnCore, Little Board, LittleBoard, MiniModule, ReadyBoard, ReadyBox, ReadyPanel, and ReadySystem are trademarks of Ampro Computers, Inc. All other marks are the property of their respective companies.

REVISION HISTORY

Revision	Reason for Change	Date
A, A	Initial Release	Dec/04
A, B	Changed password from none to "software" under "Logging In"	Dec/07

Ampro Computers, Incorporated
5215 Hellyer Avenue
San Jose, CA 95138-1007
Tel. 408 360-0200
Fax 408 360-0222
www.ampro.com

© Copyright 2004, 2007 Ampro Computers, Incorporated

Audience Assumptions

This guide is for the person who designs or uses computer related equipment, including but not limited to hardware and software design and implementation of the same. Ampro Computers, Inc. assumes you are qualified in designing and implementing your hardware designs and its related software into your prototype computer equipment.

Contents

Contents	iii
Chapter 1 Setting Up the ReadySystem	1
About the ReadySystem	1
Using this Guide	1
Requirements.....	1
What's in the Box	1
Setup Steps.....	2
Preparations.....	2
Setting Up the Workspace	2
Installing the Mounting Hardware	3
Connecting the Peripherals.....	4
Applying Power to the ReadySystem	6
Chapter 2 ReadySystem Linux Image	7
ReadySystem Linux Overview	7
About the Supplied Image.....	7
HDD Directory Structure	8
Getting Started	9
Logging In	9
Logging Out.....	9
Shutting Down Linux	9
Basic Commands	10
How to Execute a Command:	10
How to Execute a Program/Application:	10
Process Control	10
Managing Users	11
Add Users	11
Change Password.....	11
Configuring the Network.....	12
Change IP Address.....	12
Network Commands	12
Configure Network Services	13
Mounting External Storage Devices.....	14
Where do I go from here?	15
Chapter 3 Advanced Linux Options	17
Advanced Process Controls.....	17
Killing or Reconfiguring a Daemon without Restarting	17
Setting Process Priority.....	17
Setting Limits On Processes.....	18
Customize the Kernel and Test.....	18
Installing Kernel Source Code:	18
Compiling the Kernel.....	18
Install the new Kernel.....	19
Testing the Kernel.....	19
Rebuilding Hard Disk Drive	19
Accessing the Distribution CD.....	20

Chapter 4 Installing ReadySystem Options	23
CompactFlash Card Installation.....	23
Tools Required	23
Installing the CompactFlash Card	23
Removing the CompactFlash Card	25
ReadySystem Disassembly	26
Tools Required	26
Removing the ReadyBoard from Enclosure	26
Installing the ReadyBoard	29
Connecting the Cables	31
Memory Installation.....	33
Tools Required	33
Installation Guidelines	33
Removing the SODIMM.....	33
Installing the SODIMM.....	35
Appendix A Technical Support	37
Contacting Support	37

List of Figures

Figure 1-1. ReadySystem Accessories	3
Figure 1-2. Installing the Mounting Hardware.....	3
Figure 1-3. ReadySystem I/O Panel Controls and Connectors.....	4
Figure 4-1. Removing CompactFlash Protective Cover	24
Figure 4-2. Installing the CompactFlash Card	25
Figure 4-3. Removing the ReadySystem Top Cover.....	27
Figure 4-4. Disconnecting the Cables	27
Figure 4-5. Removing the Screws and the ReadyBoard	28
Figure 4-6. Separating Internal Cables.....	29
Figure 4-7. ReadyBoard Positioned Under LAN Ports	30
Figure 4-8. ReadyBoard Over Chassis Standoffs	30
Figure 4-9. Connector and Jumper Locations	31
Figure 4-10. Connector Pin-1 Locations.....	32
Figure 4-11. Removing SODIMM from Socket.....	34
Figure 4-12. Installing SODIMM into Socket	36

List of Tables

Table 1-1. ReadySystem I/O Panel Connectors, Controls, and Indicators	5
Table 2-1. Linux Directory Structure	8
Table 2-2. Basic Linux Commands.....	10
Table 2-3. List Process Commands	10
Table 3-1. Killing or Reconfiguring a Daemon.....	17
Table A-1. USA Technical Support Contact Information	37

Chapter 1 Setting Up the ReadySystem

About the ReadySystem

The ReadySystem products are intended for users of turn-key embedded systems, who prefer long lifecycle, configuration controlled computers over desktop grade systems with frequently changing motherboards. ReadySystem models feature the ReadyBoard single board computer (SBC), from the 300MHz VIA Eden CPU to the Intel 1.4GHz Pentium M 738 CPU. The Linux operating system is pre-loaded onto the internal 40GB (or greater) 2 ½" hard disk drive (HDD). Just load your application software and you are ready to run.

Using this Guide

This guide provides the most efficient way to set up your ReadySystem with Linux. The instructions provided in this guide include:

- Removing the ReadySystem from the shipping container and inventorying the accessories
- Connecting peripherals to the ReadySystem
- Powering up the ReadySystem
- Supplied Linux software usage considerations

Information not provided in this Users Guide includes:

- ReadyBoard model specifications
- Environmental requirements
- ReadyBoard model connector/pin numbers and definitions
- Linux programming or operating instructions

Requirements

The following peripherals and devices are needed to make full use of the Linux ReadySystem.

- Peripherals (Customer provided):
 - ◆ PS/2 or AT Keyboard
 - ◆ PS/2 Mouse
 - ◆ CRT Monitor
- Optional Devices/Connections (Customer provided):
 - ◆ Ethernet (LAN) connection
 - ◆ USB Devices, including a keyboard and mouse

What's in the Box

Refer to the Contents List for a list of the items in the shipping container of the first shipment of the ReadySystem, or the first box of multiple boxes. See Figure 1-1.

All subsequent ReadySystems with the same operating system will not contain all of the documentation of the first shipment, like the User Guide and the CD-ROM. However, each ReadySystem after the first shipment will have all the required accessories, such as the power cord, Y-cable, and mounting hardware.

Setup Steps

It is important to follow the setup steps in this section in the exact order listed here, but skip any steps that do not apply to your situation. References are provided to chapters within this guide or other Ampro manuals for more information about installation and use of this ReadySystem.

Preparations

1) Open shipping box	<ul style="list-style-type: none"> • Locate the ReadySystem Contents List. See Figure 1-1. • Unpack the contents of the shipping box
2) Verify Contents	<ul style="list-style-type: none"> • Verify the contents of the shipping box against the Contents List included with your ReadySystem shipping box. • If anything is missing or damaged, call your sales representative or Tech Support. Refer to Appendix A for contact information.
3) Support Documentation (ReadyBoard model Documentation and Support Software (Doc & SW) CD-ROM located in the first QuickStart Kit)	<p><i>ReadySystem Users Guide</i></p> <p>This document, shipped as a hardcopy with the first system shipment, describes how to setup and power up the ReadySystem and is also provided on the ReadyBoard model Doc & SW CD-ROM as a PDF file.</p>
	<p><i>ReadyBoard Model Reference Manual</i></p> <p>This document describes the ReadyBoard model used in the ReadySystem and provides detailed reference information for your ReadyBoard and is located on the ReadyBoard model Doc & SW CD-ROM as a PDF file</p>
	<p><i>ReadyBox Users Guide</i></p> <p>This document describes the ReadyBox and provides detailed reference information and installation instructions for ReadyBox enclosure options.</p>

Setting Up the Workspace

CAUTION	<p>To prevent damage to the ReadySystem, ensure there is sufficient clearance around the air vents for unrestricted airflow, especially the power supply vent holes.</p> <p>The air temperature inside the enclosure can rise above the specified air temperature, if the airflow through the vents is restricted.</p>
----------------	--

4) Select workbench location	<ul style="list-style-type: none"> • The workbench location should be a flat clean surface for setup and operation (including the connection of any external peripherals and optional devices). • Ensure there is sufficient airflow clearance around the complete enclosure.
5) Unpack ReadySystem	<ul style="list-style-type: none"> • Remove the ReadySystem from its shipping container and place it on a flat work surface. <p>The ReadyBoard model, the 40GB HDD (2 ½”), and Linux OS are pre-installed, internally connected, and tested prior to shipment as the ReadySystem, which is a complete assembly ready for operation.</p>

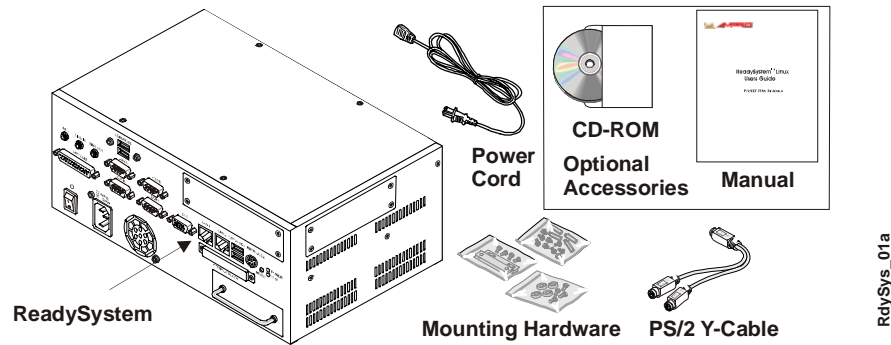

Figure 1-1. ReadySystem Accessories

Installing the Mounting Hardware

6) Connect the appropriate mounting hardware

- Connect the mounting hardware for surface or wall mounting to the bottom or rear of the ReadySystem. See Figure 1-2.

The four plastic feet are mounted prior to shipment and will protect the paint finish on the bottom of the enclosure.

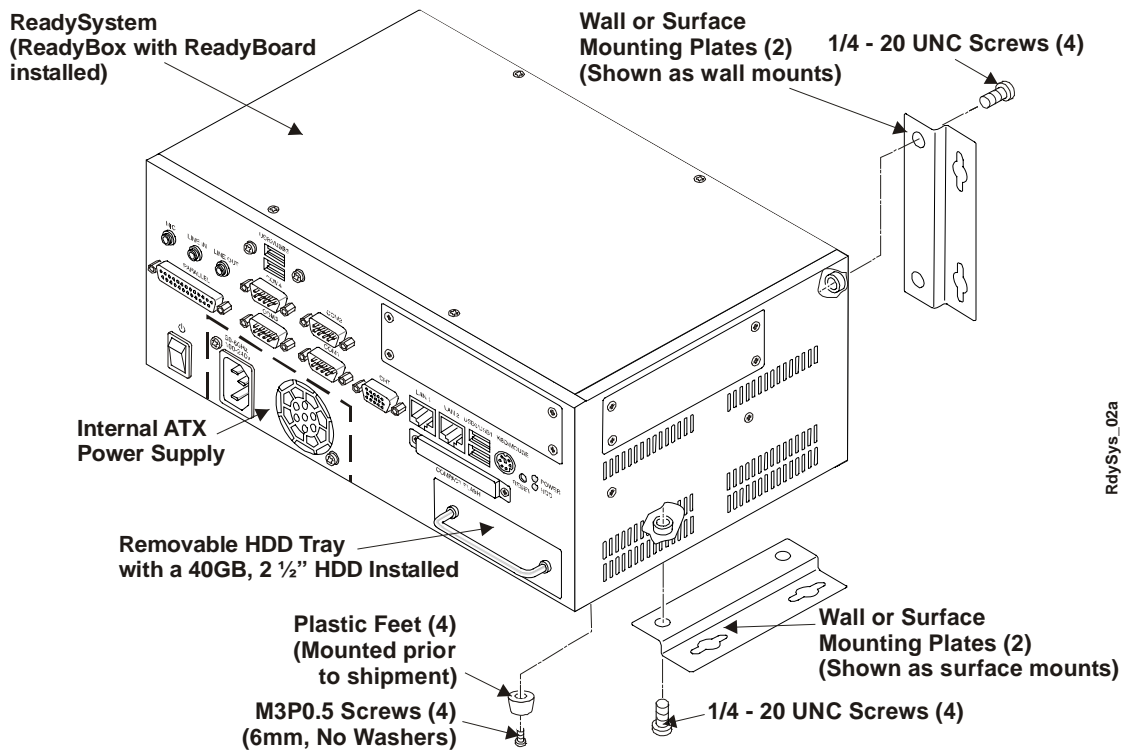
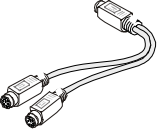

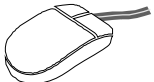
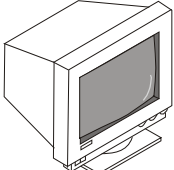

Figure 1-2. Installing the Mounting Hardware

CAUTION

To prevent damage to the internal ATX power supply, do not mount the ReadySystem so that the I/O panel is facing down. This could lead to inadequate airflow and damage to the power supply.

Connecting the Peripherals

<p>7) Connect the Y-cable and the respective peripheral cables/devices</p>	<ul style="list-style-type: none"> This includes the Y-cable for the PS/2 keyboard & mouse. Refer to Figure 1-3 and Table 1-1 for location and description of the connectors and controls.
	<ul style="list-style-type: none"> Connect the PS/2 Keyboard & Mouse Y-cable assembly to the Keyboard/Mouse port on the ReadyBox I/O Panel. See Figure 1-3. This cable assembly provides two connectors for the PS/2 Keyboard and PS/2 Mouse shared port with icons for the specific device.
	<ul style="list-style-type: none"> Connect the keyboard to the free Y-cable connector with keyboard icon on it. An AT to PS/2 keyboard adapter is provided.
	<ul style="list-style-type: none"> Connect the PS/2 mouse to the Y-cable connector with mouse icon on it.
	<ul style="list-style-type: none"> Connect the CRT monitor through its cable to the CRT (VGA) connector on the I/O Panel of the ReadyBox. See Figure 1-3.

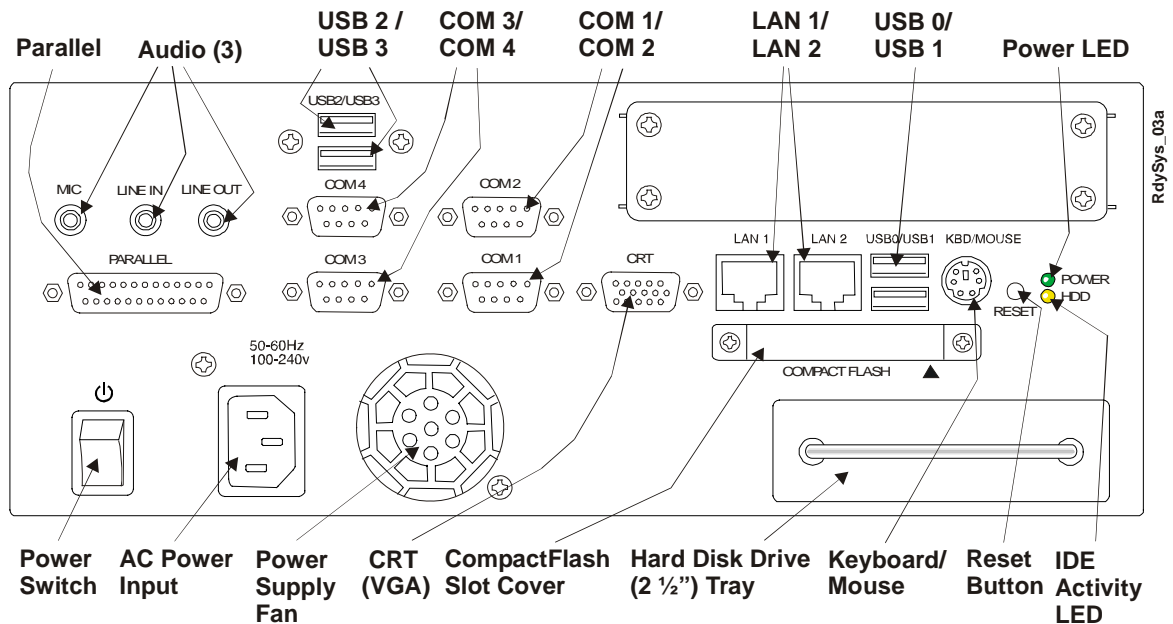

Figure 1-3. ReadySystem I/O Panel Controls and Connectors

Table 1-1. ReadySystem I/O Panel Connectors, Controls, and Indicators

Control/Connector	Description
Power Switch	Use this momentary push button Power switch for turning on the AC power.
AC Power In	Use this 3-prong connector for a standard AC input power connection. The internal ATX power supply accepts 100-to-240 VAC, +/- 10% @ 50/60 Hz.
CRT (VGA)	Use this standard 15-pin (DB15) connector for the CRT video connection.
Keyboard/Mouse	Use this PS/2 connector for Keyboard & Mouse connected through the required the PS/2 Y-cable adapter provided in the ReadySystem QuickStart kit or shipping container. The Y-cable has icons on each cable for the respective mouse or keyboard connection.
USB 0 & 1	Use these two USB connectors (4-pin connectors) for the first two USB devices connected to the ReadySystem.
USB 2 & 3	Use these two USB connectors (4-pin connectors) for the any additional USB devices connected to the ReadySystem. These USB connectors and the respective internal cables are connected to the ReadyBoard installed inside the enclosure.
LAN 1 (Ethernet 1)	This Ethernet port is typically used for the 10/100BaseT Ethernet connection (8-pin RJ45 connector).
LAN 2 (Ethernet 2)	This Ethernet port is typically used for the Gigabit Ethernet (10/100/1000BaseT) connection, if provided on the ReadyBoard model (10-pin RJ45 connector). If not, it uses the standard 8-pin RJ45 connector for 10/100BaseT Ethernet.
COM 1 & COM 2 (Serial 1 & Serial 2)	Use these two serial ports (DB9, 9-pin) for the standard RS232 connections to the ReadySystem.
COM 3 & COM 4 (Serial 3 & Serial 4)	Use these two serial ports (DB9, 9-pin) for the standard RS232 and RS485/RS422 connections to the ReadySystem. These two serial ports and the respective internal cables are connected to the ReadyBoard installed inside the enclosure.
Parallel	Use this printer port (DB25, 25-pin) connector for any printer you may wish to connect to the ReadySystem. This printer port and its internal cable are connected to the ReadyBoard installed inside the enclosure.
MIC, Line In, Line Out	Use these three Audio In/Out connectors for the standard Stereo In/Out and MIC in connections to the ReadySystem. These Audio connectors and the respective internal cable are connected to the ReadyBoard installed in the enclosure.
Power-On LED	This green power-on indicator glows when power is turned on and goes dark when power is turned off to the ReadySystem.
HDD Activity LED	This yellow IDE activity indicator flickers when there is I/O activity for the IDE hard drive or CompactFlash card used with the ReadySystem.
Reset Button	Press this reset button momentarily to reset (hard reset) the ReadySystem.
CompactFlash socket	The CompactFlash card goes through the opening in the I/O panel of the ReadySystem, if installed. The CompactFlash socket is provided on the underside of the ReadyBoard installed inside the enclosure.
Hard Disk Drive (2 1/2") Tray	The HDD tray assembly holds a 40GB (or greater), 2 1/2" hard disk drive (HDD) connected to the ReadyBoard, installed inside the enclosure.

NOTE

If you wish to connect a floppy drive or CD-ROM to the ReadySystem, you can use one of the USB ports to connect the device.

Applying Power to the ReadySystem

8) Power up the ReadySystem	<ul style="list-style-type: none"> • Connect the supplied power cord into the AC input power connector of ReadySystem. See Figure 1-3. • Plug the CRT monitor's power cord into an AC outlet, and turn on the monitor. See Figure 1-3. • Plug the ReadySystem power cord into an AC outlet. • Press the ReadySystem's momentary power switch (\approx 1 sec) before continuing. See Figure 1-3 and Table 1-1.
9) Verify the ReadySystem powers on satisfactorily	<ul style="list-style-type: none"> • If you want to enter the BIOS Setup before the GRUB screen appears, Press the key during POST at the prompt. Use BIOS Setup during the initial boot to set the desired options (time and date, etc.). • You should see POST complete successfully before the system starts loading the GRUB (GRand Unified Boot) loader screen. The GRUB boot-loader is responsible for loading and transferring control to the Linux OS initialization code. The initialization code, in turn, initializes the rest of the operating system (e.g. GNU). <div data-bbox="568 829 1323 913" style="border: 1px solid black; padding: 5px;"> <p>NOTE The 40GB (or greater) hard disk drive (2 ½") installed in the ReadySystem comes with one partition for Linux.</p> </div> <p>If you allow the GRUB loader screen to load, you should see a screen similar to the one shown below on this page.</p>
<p>GRUB version 0.91 (610k lower/31744k upper memory)</p> <div data-bbox="406 1050 1136 1228" style="border: 1px solid black; padding: 10px; margin: 10px auto; width: fit-content;"> <p>Linux (v4.0)</p> </div> <p>Use the ↑ and ↓ keys to select which entry is highlighted. Press Enter to boot the selected OS, 'e' to edit the commands before booting, 'a' to modify the kernel arguments before booting, or 'c' for a command-line.</p> <p style="text-align: right; font-size: small;">GRUBscrn03</p> <p>The highlighted entry will be booted automatically in 10 seconds.</p>	
<div data-bbox="373 1480 1226 1554" style="border: 1px solid black; padding: 5px;"> <p>NOTE To stop the autoboot timer, press the down arrow key and the prompt line will disappear, stopping the timer indefinitely.</p> </div>	
10) Using Linux Operating System (OS)	<ul style="list-style-type: none"> • You should see the Linux prompt on screen at this point, where you can log in using "root" as the user name. No password is required to log on. Refer to Chapters 2 and 3 for more information concerning the Linux OS. • If you require drivers not installed on the ReadySystem HDD (2 ½"), refer to <i>Accessing the Distribution CD</i> in Chapter 2 and the software directory on the ReadyBoard model Doc & SW CD-ROM for instructions.

Chapter 2 ReadySystem Linux Image

ReadySystem Linux Overview

ReadySystem Linux uses the TimeSys Linux kernel, which includes several enhancements to the standard Linux kernel to address the specific needs of embedded and real-time applications. The TimeSys Linux kernel is derived from the standard Linux kernel. The source code for this enhanced kernel is freely available as per the terms of the GNU Public License (GPL) and included on the CD-ROM with full source code so you can reconfigure and rebuild the kernel to meet the specific requirements of your embedded application and platform, as needed.

The primary features of ReadySystem Linux are:

- The ReadySystem Linux kernel is fully pre-emptible. A scheduling decision is made whenever an interrupt occurs, regardless of whether the processor was executing within the kernel or in user space at the time of the interrupt.
- Interrupt Handlers are run as real-time threads. This provides a prioritized, pre-emptible interrupt hierarchy.
- SoftIRQ processing, which executes interrupt bottom halves and various other kernel functions, is performed by a real-time thread.
- The scheduler makes scheduling decisions in constant time.
- Most of the critical sections in the kernel are protected by mutexes.
- A small root file system consisting of an extensive collection of development packages and utilities, precompiled for the ReadySystem.
- All modules necessary to integrate a running Linux system.
- Release notes, documentation and manual pages.

ReadySystem Linux provides a complete development environment and set of development tools for your embedded development projects.

About the Supplied Image

The Linux image on the HDD includes the Linux 2.4.18 kernel plus a full root file system. The image also includes all of the Linux/Unix tools, libraries, applications, network tools, and programming tools (gcc compiler, gdb etc...). This configuration also includes a GUI files system and a GPL version of X Windows, known as xfree86.

In addition, several other example configuration files are provided, in case a smaller or different image is desired. These are also available in the same directory.

The image provided with ReadySystem Linux has built-in drivers for:

- Internal IDE hard disk and CompactFlash card
- External USB Floppy and USB CDROM
- Serial Ports and Parallel ports
- 10/100BaseT Ethernet
- AC'97 Audio
- Keyboard/Mouse
- Video

HDD Directory Structure

Table 2-1. Linux Directory Structure

Structure	Description	
/ <ul style="list-style-type: none"> ---home (root) <ul style="list-style-type: none"> ----ftp ---bin ---sbin ---proc <ul style="list-style-type: none"> ----1 ---usr <ul style="list-style-type: none"> ----bin ----sbin ----include ----lib ----local ----man ----info ----doc ----X11R6 ---boot ---lib <ul style="list-style-type: none"> ----modules ---dev ---etc <ul style="list-style-type: none"> ----sysconfig ---var <ul style="list-style-type: none"> ----lib ----lock ----log ----run ----spool ---mnt ---tmp 	home (root)	The home directory for the root user, also contains the user's home directories where users may list additional services used.
	bin	Commands needed during bootup that might be needed by users
	sbin	Like bin but commands are not intended for normal users. Commands run by LINUX.
	proc	This filesystem is not on the disk. Exists in the kernels imagination (virtual). This directory holds information about kernel parameters and system configuration.
	1	A directory with info about process number 1. Each process has a directory below proc.
	usr	Contains all commands, libraries, man pages, games and static files for normal operation
	bin	Stores almost all user commands. See also /bin or /usr/local/bin.
	sbin	System admin commands not required on the root filesystem. e.g., most server programs.
	include	Header files for the C programming language.
	lib	Unchanging data files for programs and subsystems
	local	Location of locally installed software and other files
	man	Manual pages
	info	Info documents
	doc	Documentation for various packages
	X11R6	The X windows system files. There is a directory similar to usr below this directory
	boot	Files used by the bootstrap loader, GRUB. Kernal images are often kept here.
	lib	Shared libraries needed by the programs on the root filesystem
	modules	Loadable kernel modules, especially those needed to boot the system after disasters.
	dev	Device files for devices such as disk drives, serial ports, etc.
	etc	Configuration files specific to the machine.
	sysconfig	Files that configure the linux system for networking, keyboard, time, etc.
	var	Contains files that change for mail, news, printers, log files, man pages, temp files
	lib	Files that change while the system is running normally
	lock	Lock files used by a program indicating it is using a particular device or file
	log	Stored log files from programs such as login and syslog, which record all logins, logouts, and other system messages.
	run	Files containing valid information concerning the system until the next system boot

Structure	Description	
	spool	Directories for mail, printer spools, news and other spooled work.
	mnt	Mount points for temporary mounts by the system administrator.
	tmp	Temporary files. Programs running after bootup should use /var/tmp.

Getting Started

Once you have successfully booted your ReadySystem, congratulations, you're running Linux! However, you may want to know how to perform a few basic commands and functions.

Logging In

Once you have connected and powered up your ReadySystem, it has completed POST successfully, and the GRUB screen has been loaded and executed, you will see the login prompt on your monitor.

1. To log in, type the name of a user for the login name.

Ampro set up this image to use *root* as the default user name and root has been set up as a "super user".

2. If you have enabled a password, then enter it now.

Ampro has set up this image with "software" as the default password.

You can also set a password for root and create additional accounts. Refer to *Managing Users* later in this chapter.

Logging Out

If you want to exit any given session, then you need to use the logout command.

1. At the prompt type:

```
logout
```

If you have logged in, then typed "su" to become a superuser or another user, you may need to type "exit" until your SHLVL environment value is 1. Then you can type "logout" to exit your session. The "exit" command will take you back to previous shell levels.

Shutting Down Linux

If you want to shutdown your ReadySystem using software commands, then you need to initiate the shutdown sequence.

1. At the keyboard, use the following keystroke combination it initiates a shutdown.

```
<CTRL><ALT><DEL>
```

This keystroke combination issues the shutdown command through the init program, and will shutdown not only the Linux OS, but also the ReadySystem as well.

Basic Commands

How to Execute a Command:

The following table has some basic Linux commands. Enter the name of the command and its parameter at the prompt, and then press Enter.

Table 2-2. Basic Linux Commands

Command	Description
ls	List the contents of a directory
cd	Changes the current directory
mv	Changes the name of a file/directory
cp	Copies files or directories

How to Execute a Program/Application:

To execute a program or application in Linux, you must have the name of program or application, the path to the program, and the program's parameters. For example, if you have a program named "helloworld" in the directory /home/root/ and the current directory is /home/root/, then any of the following example lines, less the comment characters, would execute the helloworld program.

1. Enter the path to the program, the name of the program, and its parameters.

The path can be a relative path or absolute path. If the path of the program has been added into the environment variable PATH, then no path is needed. The PATH is set in /etc/profile.

```
#/home/root/helloworld    {this uses absolute path}
#./helloworld             {this uses relative path, refer to
                           current directory}
#~root/helloworld        {this uses relative path, refer to the
                           home directory of the user "root"}
#helloworld              {this uses PATH if the program path has
                           been included in /home/root}
```

2. Once you have entered the preceding information, press Enter.

Process Control

List Processes - The ps command is used to list processes in the system.

Table 2-3. List Process Commands

Command	Description
ps	This command, with no options, will list the current processes running.
ps - a	This option will list processes started by all users in the system
ps - A	This option will list all processes in the system

Note: Each process listed by ps is associated with a number called the process ID or PID. This number is printed at the beginning of each output line of the ps command.

Kill a Process

Linux provides commands to stop or kill a process while it is running in the system.

To stop or kill a process, type the command "kill" and the PID (process ID).

```
#kill 1234
```

For more information on Process Control, type “man kill” to read the manual for kill.

Managing Users

Add Users

You can create a user account in Linux for a user (`user_name`) and when you do, the home directory for this user account will automatically be created as `/home/user_name`. Once created, the user will be prompted to enter a password for the newly created account.

1. To add a user (`user_name`), type the `adduser` command followed by the user name at the prompt:

```
#adduser user_name
```

The home directory for this user name will automatically be created.

Change Password

The change password command, `passwd`, is used to change user passwords.

1. To change the user password, type the `passwd` command followed by `user_name` at the prompt:

```
#passwd user_name
```

The Linux OS will prompt you to enter the old password and the new password.

2. Enter the old and new passwords and then press Enter.

If you do not enter a parameter for the old password, the `passwd` command will change the password of “root” user to the new password. For more information, type “man passwd” to read the manual for the `passwd` command.

Configuring the Network

Change IP Address

To change the Ethernet address, you will open the file (using vi) in the following directory and modify the IP address as necessary in the following example:

```
/etc/network/interfaces
```

The example below shows the contents of /etc/network/interfaces.

1. Modify the IP address fields (using vi) to match your network configuration and execute.

```
# /etc/network/interfaces - configuration file for ifup(8), ifdown(8)  
# The loopback interface  
iface lo inet loopback  
auto lo  
  
# The first ethernet port, using static IP  
# (network, broadcast and gateway are optional)  
iface eth0 inet static  
    address 192.168.0.12  
    netmask 255.255.255.0  
    network 192.168.0.0  
    broadcast 192.168.0.1  
    gateway 192.168.0.1  
  
auto eth0  
  
# The second ethernet port, using dhcp  
iface eth1 inet dhcp  
auto eth1
```

For more information on how to configure inittab, type “man inittab” to read the manual for inittab.

Network Commands

The ifconfig, ifup, and ifdown commands are used to display and control network configurations of the network circuitry or Ethernet port.

1. At the prompt type

```
#ifconfig eth0
```

If no parameter is provided, ifconfig will show the network configuration of all network circuitry.

For more information, type “man ifconfig” to read the manual for ifconfig.

2. To start the network circuitry or an Ethernet port, type the following at the prompt.

```
#ifup eth0
```

3. To start the second network circuitry or an Ethernet port, type the following at the prompt.

```
#ifup eth1
```

For more information, type “man ifup” to read the manual for ifup.

4. To stop the network circuitry or Ethernet port, type the following at the prompt.

```
#ifdown eth1
```

5. To restart all network circuitry or Ethernet ports, type the following at the prompt.

```
#/etc/init.d/networking restart
```

Configure Network Services

To configure network services such as FTP server, Telnet server, etc., you will go to /etc/xinetd.d directory and modify the corresponding files.

For example, to configure the FTP server, you will open and modify the file /etc/xinetd.d/ftpd.

1. To enable a service set to “disabled” by default, open the corresponding file.
2. Change the following line from disabled to enabled by typing “no” in place of “yes”.

```
change "disable = yes" to "disable = no"
```

3. Restart xinetd by running the following command:

```
#/etc/init.d/xinetd restart
```

Mounting External Storage Devices

To use external storage devices such as legacy or USB floppy disk drive, IDE or USB hard disk drives, USB CD-ROMs, USB memory keys, or optional CompactFlash™ cards, etc. you will use the mount command to mount the device to a directory and then access the device much like a normal directory. However, some devices use a delay write so the information may not be written to the device until the device is dismounted using the umount command.

The first parameter of the mount command is the device name and the second parameter is the directory where the device will be mounted.

1. To mount a legacy floppy disk drive, type the following text at the prompt:

```
#mount /dev/floppy/0 /mnt/floppy
```

2. To un-mount the legacy floppy disk drive, type the following text at the prompt:

```
#umount /dev/floppy/0
```

The floppy disk drive is a delay write device, so you may need to type the following text at the prompt, to ensure all updated files have been written to the disk.

```
#umount /mnt/floppy
```

3. The IDE hard disk drive (2 ½") in the ReadySystem has the Linux OS installed on the one and only Linux partition on the drive and is set up as the root file system. It is not necessary to mount an IDE hard disk drive to the ReadySystem, but you could add a USB hard disk drive.
4. If you wish to mount an external USB drive as a second hard disk drive, you would type the following text at the prompt:

```
#mount /dev/discs/disc1/part1 /mnt/hd
```

The device name for the first partition of the second hard disk drive is /dev/discs/disc1/part 1 and the device name for the m partition of the n hard disk drive is /dev/discs/discn/part m.

NOTE

All hard disk drives, CompactFlash card, even USB storage devices such as ZIP drives, USB memory key, etc. will be in /dev/discs/ directory

5. To mount a CompactFlash card on the /mnt/cf directory, type the following text at the prompt

```
#mount /dev/discs/disc1/part1 /mnt/cf
```

The CompactFlash card is treated as a hard disk drive and mounted in the same fashion as an IDE hard disk drive. The device name for the first partition on the CompactFlash card is /dev/discs/disc1/part 1

- To mount an external CD-ROM, type the following text at the prompt:

```
#mount /dev/cdroms/0 /mnt/cdrom
```

NOTE	USB storage devices are treated as SCSI devices in the Linux ReadySystem and are therefore, mounted under /dev/scsi directory. However, the name of these devices under the /dev/scsi directory will be longer than under /dev/discs/ directory.
-------------	--

- To mount a USB memory key or similar device, type the following text at the prompt.

```
#mount /dev/discs/disc1/part1 /mnt/usbkey
```

The USB key will be treated similar to CF card or hard disk. The USB device name will be added to boot order of /dev/discs/disc1, such as disc2, disc3. The name of the USB device in the boot order depends on how it is attached to the ReadySystem.

For example, if you insert the CF card first, followed by two USB keys, then the name of CF card will be /dev/discs/disc1 and the names of two USB keys will be /dev/discs/disc2 and /dev/discs/disc3 respectively.

Where do I go from here?

You are ready to load and run applications over your network, or you can install applications onto the internal HDD where you run these applications. You can install applications onto the internal HDD from an external USB floppy disk drive, external USB CD-ROM drive, or from your network.

- ◆ If you would like to do some advanced configuration of Linux, refer to Chapter 3, *Advanced Linux Options*.
- ◆ If you would like to install a CompactFlash card, or change the ReadySystem options, go to Chapter 4, *Installing ReadySystem Options*.

Chapter 3 Advanced Linux Options

The procedures in this chapter describe how to use the more advanced features of Linux on the ReadySystem, such as customizing and rebuilding the kernel and setting priorities of processes.

Advanced Process Controls

Killing or Reconfiguring a Daemon without Restarting

These examples make use of the xinetd process.

Table 3-1. Killing or Reconfiguring a Daemon

<code>killall 1xinetd</code>	Restarts xinetd by sending signal number 1 which is the hangup signal.
<code>killall HUPxinetd</code>	Causes the daemon to reload its config file by sending the hangup signal. The difference between this example and the previous one is the signal is called by name here rather than number.

To make changes to xinetd:

1. Reconfigure `/etc/xinetd.conf`
2. Restart inetd by sending it the hangup signal

The easy way to reset a service that was started via the rc script files during system startup:

1. Find the desired file for the service, you want to start.

For example find the file for “networking”. These files should typically be in the directory `/etc/init.d`. The file name in this case is “networking”.

This is a script file that starts the daemon, not the actual binary daemon file.

2. Go to the subdirectory “`cd /etc/init.d`” and type “`./networking restart`”.

You should get output to the screen that indicates this service has been shut down and then started.

Setting Process Priority

In Linux, processes have a priority number between -20 and 19. The value of -20 is the highest, and 19 is the lowest priority. Process priority can be set with the `nice(1)` command and changed using the `renice(8)` command. To set a process to have the highest priority find the process ID number using the `ps` command.

1. If your process name is “myprog” type:

```
ps -ax |grep myprog
```

You should get something like:

```
756 tty1 S 0:00 myprog
```

The first number on the line is your process ID.

2. Enter the command:

```
renice -20 756
```

This will set your process (PID=756) to priority of -20.

3. Modify the process ID number of the program running on your system.

You can use the `nice` command to determine the default priority of new processes by typing `nice` on the command line. If you want to start a process with a specific priority, use the `nice(1)` command when you invoke the process.

Setting Limits On Processes

You can set limits on the on the number of processes that can run. The command “`ulimit`” is used to limit the number of processes users can run along with available system resources. All processes started from the shell (bash in many cases), will have the same resource limits. See the bash manual page for more information. To set the limits for daemons, which are running at boot time add `ulimit` command to boot scripts.

The command “`ulimit -a`” reports the current limits.

Customize the Kernel and Test

Installing Kernel Source Code:

The ReadyBoard model Support Software CD-ROM has the kernel source code on the CD-ROM in the `Software/TSLinux/tslinux-x86bsp` directory.

1. Insert the ReadyBoard model CD-ROM in the CD-ROM drive to install the kernel source code.
2. Execute the following commands to install the kernel source code.

```
#mount /dev/cdroms/cdrom0 /mnt/cdrom
#cd /mnt/cdrom/Software/TSLinux/tslinux-x86bsp/
#./install
```

The installation script will prompt you to select the TimeSys product.

3. Select “1” (GPL) and follow instructions on the screen to finish the installation.
Ampro recommends choosing all defaults (just type “Enter” at the prompt).

Compiling the Kernel

1. Go to the kernel directory `/opt/timesys/linux/4.0/x86bsp/src`.

The source code for the kernel is located at `/opt/timesys/linux/4.0/x86bsp/src`. The `menuconfig` file does the compiling. The kernel is modified by typing `make menuconfig` and the values in it are used to determine defaults while doing the “`make menuconfig`”.

CAUTION Ampro recommends making a copy of the source code before changing it.

2. Type the following commands at the prompt to make a back-up of the source code, before changing it.

```
#cp -rd ../src ../src.bak
```

3. Type `make menuconfig`.

When the menu appears, select the components to be included in the kernel or just accept all components as the defaults.

4. To exit the menu, choose **Exit** and **Yes** to confirm the configuration to be saved.

5. Type `make dep` to create the dependency links between files.
6. Type `make bzImage` to build the kernel.

This step will take some time to complete in the first run.

If the kernel is small, type `make zImage`.

Install the new Kernel

After the compilation finish, the new kernel will be in `arch/i386/boot` directory.

NOTE Ampro recommends using a different name and change the `grub.config` file to boot the new image.

To install the new kernel and configure grub, assume the new kernel name will be `bzImageTest`.

```
#cp arch/i386/boot/bzImage /boot/bzImageTest
```

1. Use `vi` to open `/boot/grub/grub.conf`
2. Copy the block of current boot options and paste it below the image.
3. Modify the image to boot from `/boot/bzImageTest`.

The example grub listed here shows the results after adding boot for `bzImageTest`.

```
title TimeSys Linux
    root (hd0,0)
    kernel /boot/bzImageRB800 ro
ip=100.10.10.111:::255.255.255.0:Ampro:eth0 root=/dev/hada1 rw

title Testing
    root (hd0,0)
    kernel /boot/bzImageTest ro
ip=100.10.10.111:::255.255.255.0:Ampro:eth0 root=/dev/hda1 rw
```

Testing the Kernel

After rebooting, the system will prompt you to choose between the preinstalled kernel and the new kernel (`bzImageTest`).

1. Choose “Testing” to test the new kernel.
2. If the new kernel crashes, reboot and choose the preinstalled kernel (“TimeSys Linux”).

Rebuilding Hard Disk Drive

The *Reinstall CD* provided with the ReadySystem will be used to rebuild the image on the hard disk drive (2 ½") in the ReadySystem.

CAUTION If you use the rebuilding CD-ROM to restore the Linux image, the files and work you have stored on the HDD (2 ½") will be lost, if you do not back it up before restoring the image.

Following these steps to reinstall ReadySystem software:

1. Insert the *Reinstall CD-ROM* into CD-ROM drive and reboot.
2. Go to the BIOS settings by pressing the key right after the beep to go to CMOS Setting.
3. Change the drive settings to boot from the CD-ROM before booting from Hard Disk.
4. Save changes and Exit.

The system will reboot and the software will be installed to the hard disk. This process will take approximately 15 minutes.

5. After the installation process completes, remove the *Reinstall CD-ROM* and reboot the system.

Accessing the Distribution CD

The Linux distribution and the any drivers you may need are on the ReadyBoard model Support Software CD-ROM. To access the ReadyBoard model CD-ROM, use the following procedure.

1. Run the ReadyBoard model CD-ROM to access the ReadyBoard documentation, Board Support Package, Linux Distribution, utilities, and OS drivers not on the manufacturer's diskette(s) or CD-ROM.

The ReadyBoard CD-ROM will operate on any Windows or Linux PC, allowing you to view, download, or print the contents of the CD-ROM. This includes the *ReadySystem Users Guide*, *ReadyBoard Reference Manual*, Release Notes, software drivers and various utilities.

NOTE

You must have an Internet browser to view the main menu and make selections (examples: Microsoft Internet Explorer 4.x, or greater, Netscape Navigator version 4.x, or greater, or the equivalent on a PC). Software download links are provided for Adobe Acrobat Reader version 4.x or greater to view the manuals and documents.

An Internet connection is required for the Adobe Acrobat link or access to the Ampro web site.

The ReadyBoard CD-ROM should auto-start, but if it does not, go to the root level of the CD-ROM and locate the index.htm by:

- a. Selecting Run from the Start menu in any Windows PC.
- b. Browsing the contents of the CD-ROM until you find the index.htm at the root level.
- c. Select this file and press OK to start the CD-ROM.

The CD-ROM starts and opens the main menu of the CD-ROM.

2. Select from the directories as shown below:

- ◆ ReadyBoard model SBC Documentation (ReadyBoard model Software Release Notes, Reference Manual, QuickStart Guide, ReadyBox Users Guide and the ReadySystem Users Guide)
- ◆ ReadyBoard model SBC Software (Supported operating system Board Support Packages (BSPs), additional drivers, BIOS, and code examples)
- ◆ Need Adobe Acrobat? (Link to Adobe Acrobat Reader; need Internet connection)

There are directories and subdirectories under these topics that should provide you with the needed manuals, utilities, and tools not explained earlier.

3. Install any special OS drivers not found on the manufacturer's diskette(s) or CD-ROM.

Refer to the directories under the Software menu on the ReadyBoard model CD-ROM for instructions on installing the special drivers for the desired OS.

If the desired drivers can not be found, contact Ampro through the Ask an Expert on the web site with a request for the driver(s). Or, use the Getting Updates link to Ampro's web site on the ReadyBoard model CD-ROM. Refer also to the Appendix A, Technical Support for more information.

4. Install any utilities or other development tools you may need from the ReadyBoard model CD-ROM.

Refer to the directories under the Software menu on the ReadyBoard model CD-ROM for instructions on installing and using the utilities or development tools for the desired OS.

Chapter 4 Installing ReadySystem Options

The procedures in this chapter describe how to install or remove the ReadySystem supported options. This includes removing/installing the CompactFlash card and its cover, as well as removing the ReadyBoard model SBC from the ReadySystem enclosure and removing or installing memory.

NOTE	The ReadyBoard 700 is used in these ReadyBoard examples, but you will need to refer to the specific documentation referenced here for your specific ReadyBoard model to locate and identify the jumper and connector locations that apply to your specific ReadyBoard model. Refer to the ReadyBox Users Guide, ReadyBoard model QuickStart Guide, or the ReadyBoard model Reference Manual for more specific installation/removal information than is provided in this Chapter.
-------------	---

CompactFlash Card Installation

This brief procedure describes how to remove the protective cover over the CompactFlash opening and installing the CompactFlash card into the slot opening provided in the I/O panel. Refer to the ReadyBoard QuickStart Guide for specific CompactFlash jumper settings and compatibility.

NOTE	Use only Type I or II PC cards from commercially available suppliers, but check for compatibility with UDMA 100 IDE hard disk drives. Older CompactFlash cards that are not compatible with UDMA 100 IDE hard disk drives may cause system hangs.
-------------	---

Tools Required

Use these tools to remove and install the CompactFlash card into or out of the ReadySystem.

- Small to medium Phillips screwdriver
- Anti-static service kit - Use a complete anti-static service kit (or the equivalent) to remove or install the CompactFlash card. A complete anti-static service kit should include a static-dissipating work surface, a chassis clip lead, and a wrist or ankle strap.

Installing the CompactFlash Card

1. CompactFlash (CF) Card installation preparation:
 - ◆ If the ReadySystem is already prepared for CompactFlash installation, including removal of the CF cover, with power turned off and the power cord disconnected, skip to Step 5.
 - ◆ If the ReadySystem power is connected and operating, continue with next step.

CAUTION	To prevent damage to the ReadyBoard, ensure the power switch on the ReadyBox is turned off and the power cord has been removed from the AC power source. The ATX power supply will continue to provide standby current to the chassis until the power cord is disconnected.
----------------	---

2. Initiate a shut down sequence through the OS, or hold the power switch in for 4-6 seconds to turn power off.
The Power LED should turn off completely when the power is turned off.
3. Disconnect the power cord from the AC power source.

CAUTION To prevent damage to the ReadyBoard or the CompactFlash card, ensure you discharge yourself and follow good Electro Static Prevention principals before touching either one. The ReadyBoard and the CompactFlash card are sensitive to static electricity and can be easily damaged by improper handling. Do the following when handling either one:

Leave the CompactFlash in the anti-static bag until you are ready to install it.

Always use an anti-static wrist/ankle strap and a grounding mat.

Before you remove a CompactFlash from the anti-static bag, touch a grounded, unpainted metal surface to discharge any static electricity.

4. Use a Phillips screwdriver to remove the CompactFlash cover and place the two screws in a safe place for later use. See Figure 4-1.
5. If necessary, inspect the socket for bent pins or debris on the pins of the CompactFlash socket.
6. Remove the CompactFlash card from its protective bag, handling the CompactFlash card by its edges.

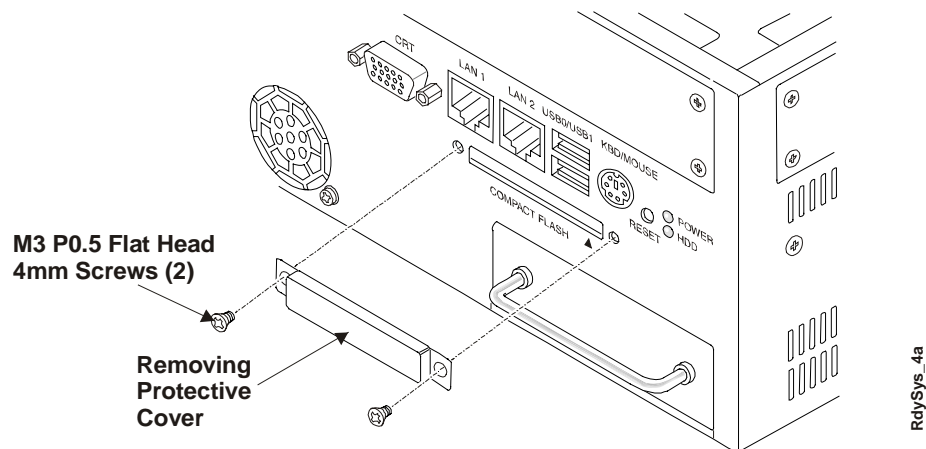

Figure 4-1. Removing CompactFlash Protective Cover

CAUTION To prevent damage to the ReadyBoard and CompactFlash card, do not force the CompactFlash card into the slot. If you have to force the CompactFlash card into the slot, it is not installed correctly.

The CompactFlash sockets on the ReadyBoard series have enough flexibility in the socket to expand when the CF is installed incorrectly.

7. Insert the CompactFlash card into the opening provided by matching the pin-1 orientation of the CompactFlash card with the arrowhead on the I/O panel. See Figure 4-2.

NOTE The keyed slots and lip (or catch edge) on the CompactFlash card are used to install into the socket in only one orientation. Pin-1 one should be down and to the right as shown in the Figure 4-2.

8. Push the CompactFlash card into the opening until it is firmly into the socket and mates with the pins. See Figure 4-2.

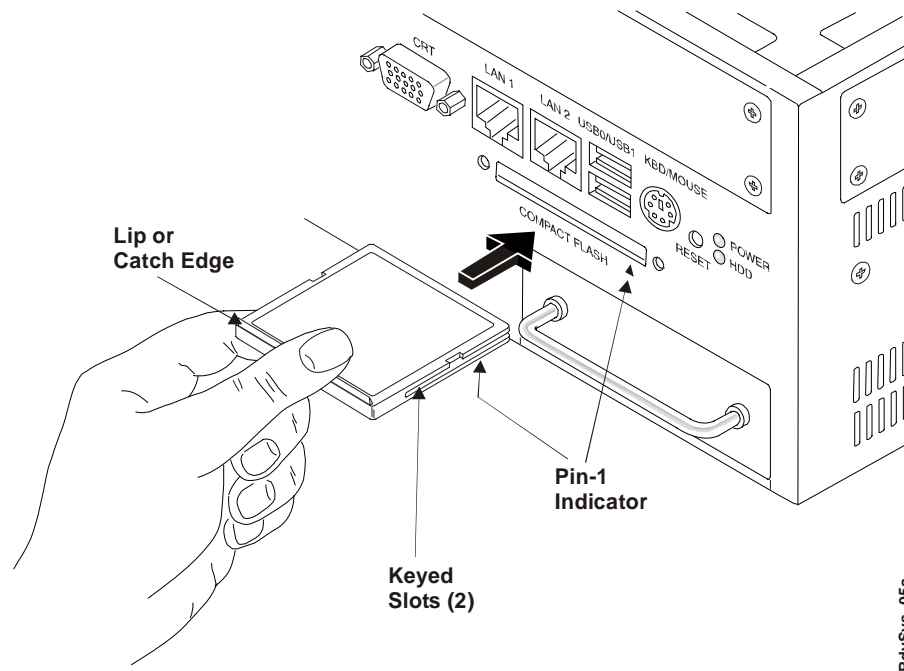

Figure 4-2. Installing the CompactFlash Card

9. If your application or environment requires protection of the CompactFlash card, for security or EMI value, you can re-install the protective cover over the CompactFlash card. See Figure 4-1. Reconnecting the protective cover will provide full EMI protection.
10. Refer to the ReadyBoard QuickStart Guide for any required jumper settings for the CompactFlash card, before restoring power to the ReadyBox.

Removing the CompactFlash Card

To remove the CompactFlash card from the ReadySystem through the enclosure opening, simply reverse the installation procedure and follow all of the safety precautions listed.

ReadySystem Disassembly

Accessing the bottom of the ReadyBoard, where the SODIMM memory is installed, requires removing the ReadyBoard from the ReadySystem enclosure. The following procedures described how to remove from and re-install the ReadyBoard into the ReadySystem enclosure.

Tools Required

The following tools are needed to remove and install the ReadyBoard SBC from or into the ReadySystem enclosure (ReadyBox).

- Small to medium Phillips screwdriver
- Use a complete anti-static service kit (or the equivalent) to remove or install the Disk On Chip onto the ReadyBoard. A complete anti-static service kit should include a static-dissipating work surface, a chassis clip lead, and a wrist or ankle strap.

Removing the ReadyBoard from Enclosure

CAUTION	To prevent damage to the ReadyBoard SBC, ensure power in the ReadyBox is turned off and the power cord has been removed from the AC outlet. The ReadyBox power supply will continue to provide standby current to the enclosure until the power cord is disconnected.
----------------	---

1. Prepare the ReadySystem enclosure for ReadyBoard removal:
 - ♦ If the ReadySystem is already prepared for ReadyBoard removal, with the power turned off, power cord disconnected, top cover removed and all the cables disconnected, skip to Step 8.
 - ♦ If the ReadySystem is powered on continue with the next step.
2. Initiate a shut down sequence through the OS, or hold the power switch in for 4-6 seconds to turn power off. See Figure 1-3.

The Power LED should turn off completely when the power is turned off.
3. Remove the power cord from the AC outlet.

CAUTION	To prevent damage to the Top Cover after removing the seven screws, you must slide the top cover to the left before lifting the Top Cover off the enclosure, due to the Z-Bracket Lip.
----------------	--

4. Remove the seven screws holding the top cover to the ReadySystem enclosure and then slide the cover to the left as shown in the Figure 4-3.
5. If you have installed or your ReadySystem shipped with PC/104 expansion board(s) connected to the ReadyBoard, you will need to disconnect and remove these PC/104 boards from the ReadyBoard before removing it from the enclosure.

Refer to the respective manuals for the PC/104 expansion boards to disconnect and remove these PC/104 boards.

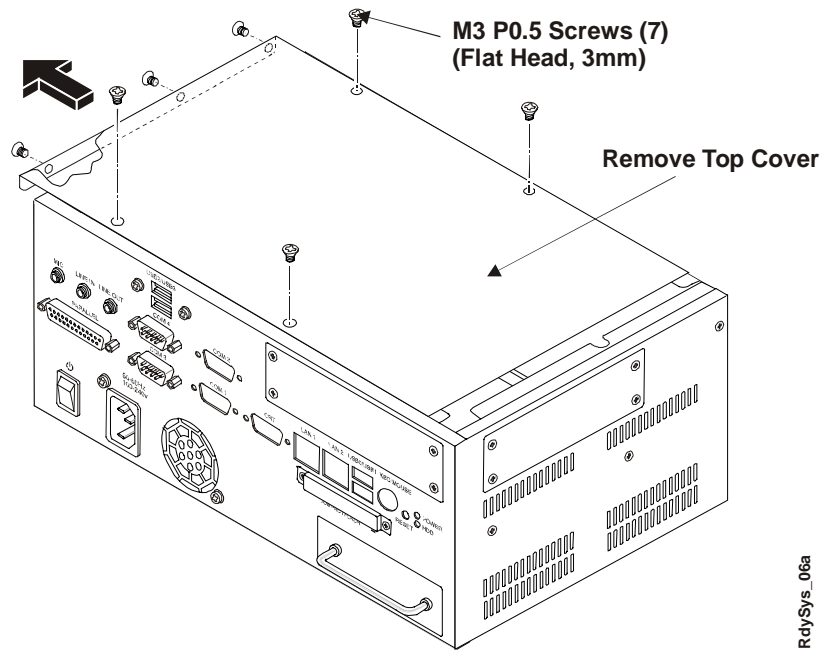

RdySys_06a

Figure 4-3. Removing the ReadySystem Top Cover

6. You may disconnect the cables to the ReadyBoard in any order, but do so carefully. See Figures 4-4, 4-9, and 4-10 for connector assignments.
7. Lay the free ends of cables aside and out of the way for re-assembly later. See Figure 4-6.

The parallel/floppy cable and the IDE cable must remain under or near the board location and near the connectors on the board when disconnected.

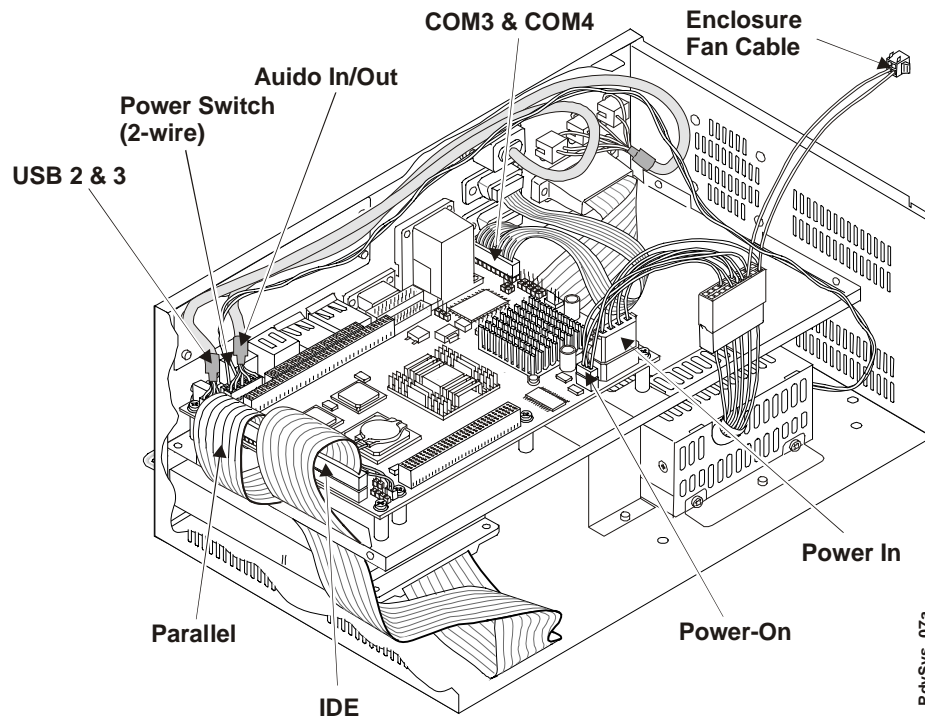

RdySys_07a

Figure 4-4. Disconnecting the Cables

CAUTION To prevent damage to the static sensitive components on the ReadyBoard, ensure you follow good Electrostatic Discharge principles. Components on the ReadyBoard are sensitive to static electricity and can be easily damaged by improper handling. Do the following when handling the ReadyBoard:

Always use an anti-static wrist/ankle strap and a grounding mat.

Before you handle the ReadyBoard, touch a grounded, unpainted metal surface to discharge any static electricity.

8. Remove the four to eight screws holding the ReadyBoard to the inside of the enclosure. See Figure 4-5.

If there are PC/104 expansion board(s) still connected to the ReadyBoard that you have not removed yet, you will need to disconnect and remove these PC/104 boards from the ReadyBoard before removing it from the enclosure. Refer to the respective manuals for the PC/104 expansion boards to disconnect and remove these PC/104 boards.

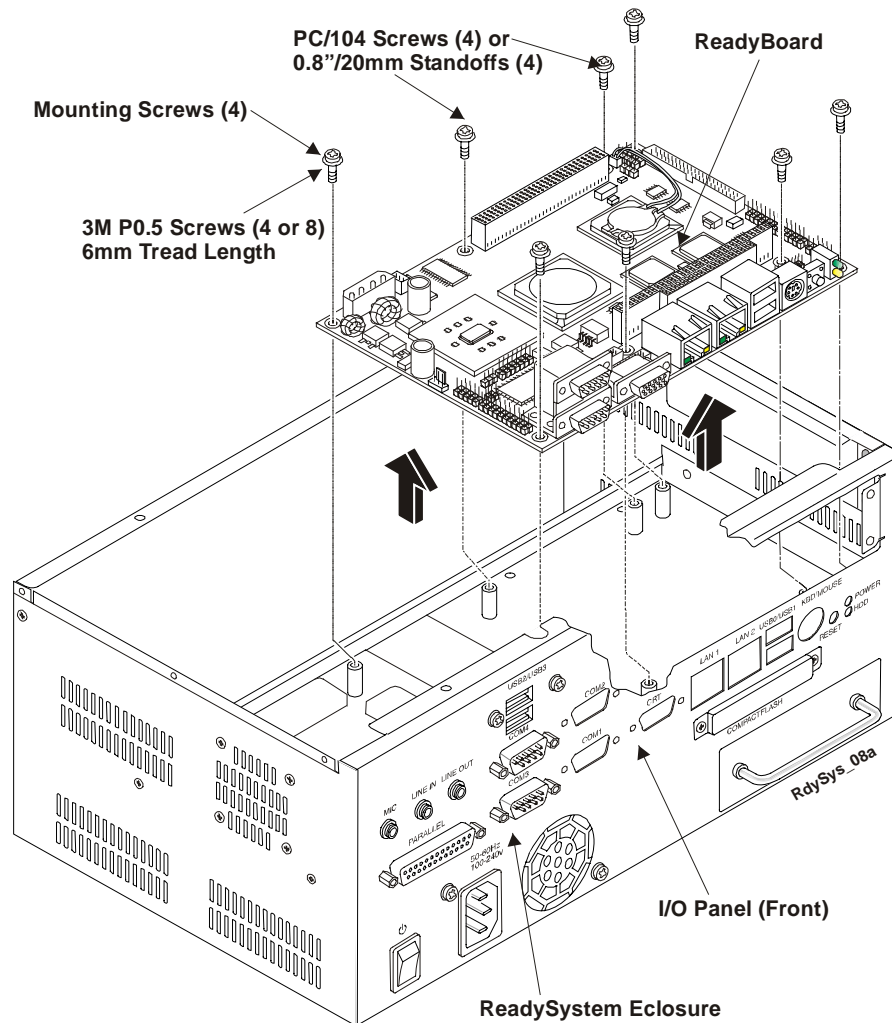

Figure 4-5. Removing the Screws and the ReadyBoard

9. Once you have removed all of the screws (and PC/104 boards) slowly work the ReadyBoard out of the enclosure until it is safely clear and place it on a protective surface. See Figure 4-5.

Installing the ReadyBoard

1. Prepare the ReadySystem enclosure and ReadyBoard for installation.
 - ◆ If the ReadySystem enclosure is already prepared for ReadyBoard installation, with the top cover removed, the parallel cable in the correct position, and the power cord disconnected, skip to Step 5.

This includes installing the correct size SODIMM onto the ReadyBoard, since you will not have access to the SODIMM socket once the ReadyBoard is installed into the enclosure.

- ◆ If the ReadyBox is not ready for the ReadyBoard installation, continue with the next step.

CAUTION	To prevent damage to the ReadyBoard, ensure the power cord has been removed from the power source. The ATX power supply inside the ReadyBox will continue to provide standby current to the connectors until the power cord is disconnected.
----------------	--

2. Ensure the power cord is still disconnected from the AC power source.

CAUTION	To prevent damage to the Top Cover after removing the screws, you must slide the top cover to the left before lifting the Top Cover off the enclosure, due to the Z-Bracket Lip.
----------------	--

3. If the top cover was replaced with a few screws holding it in place, remove all the screws holding it in place and then slide the cover to the left as shown in Figure 4-3.
4. Move the internal cables out of the way to allow installation of the ReadyBoard. See Figure 4-6.

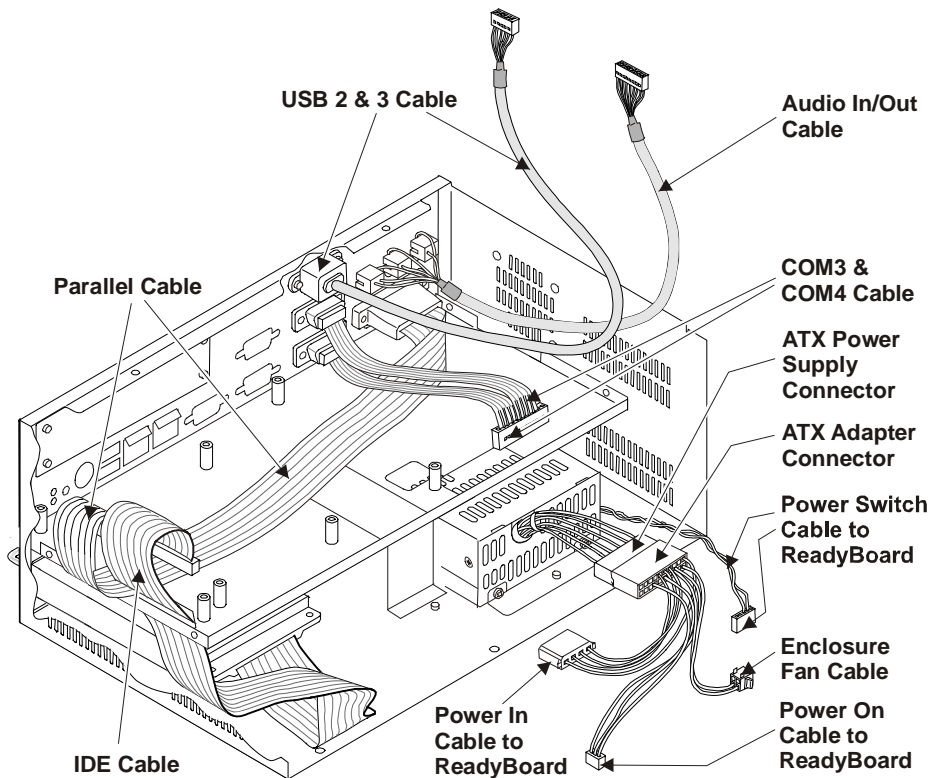

Figure 4-6. Separating Internal Cables

5. Position the ReadyBoard near the eight standoffs on the enclosure shelf at about a 10° angle to the mounting shelf. See Figures 4-7 and 4-8.

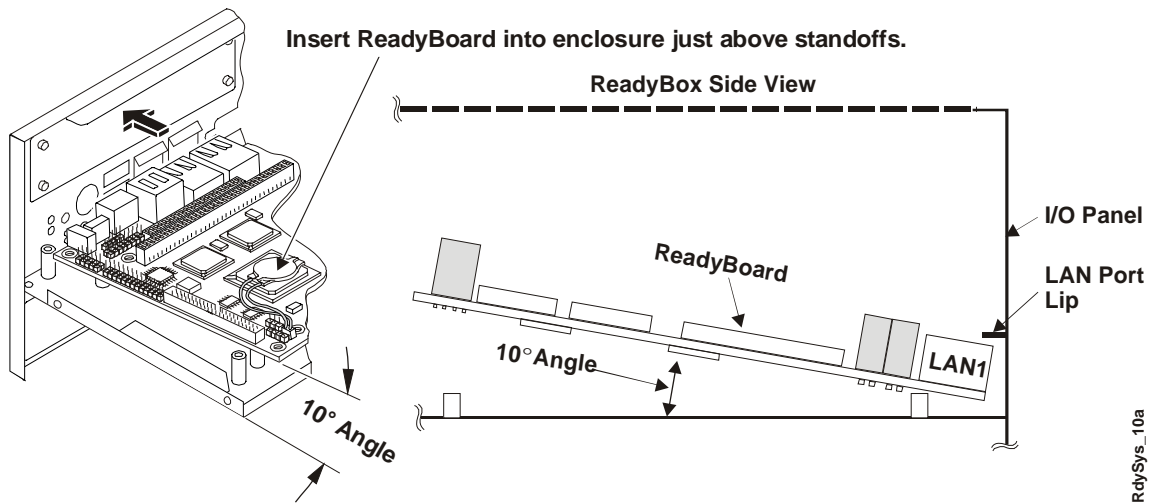

Figure 4-7. ReadyBoard Positioned Under LAN Ports

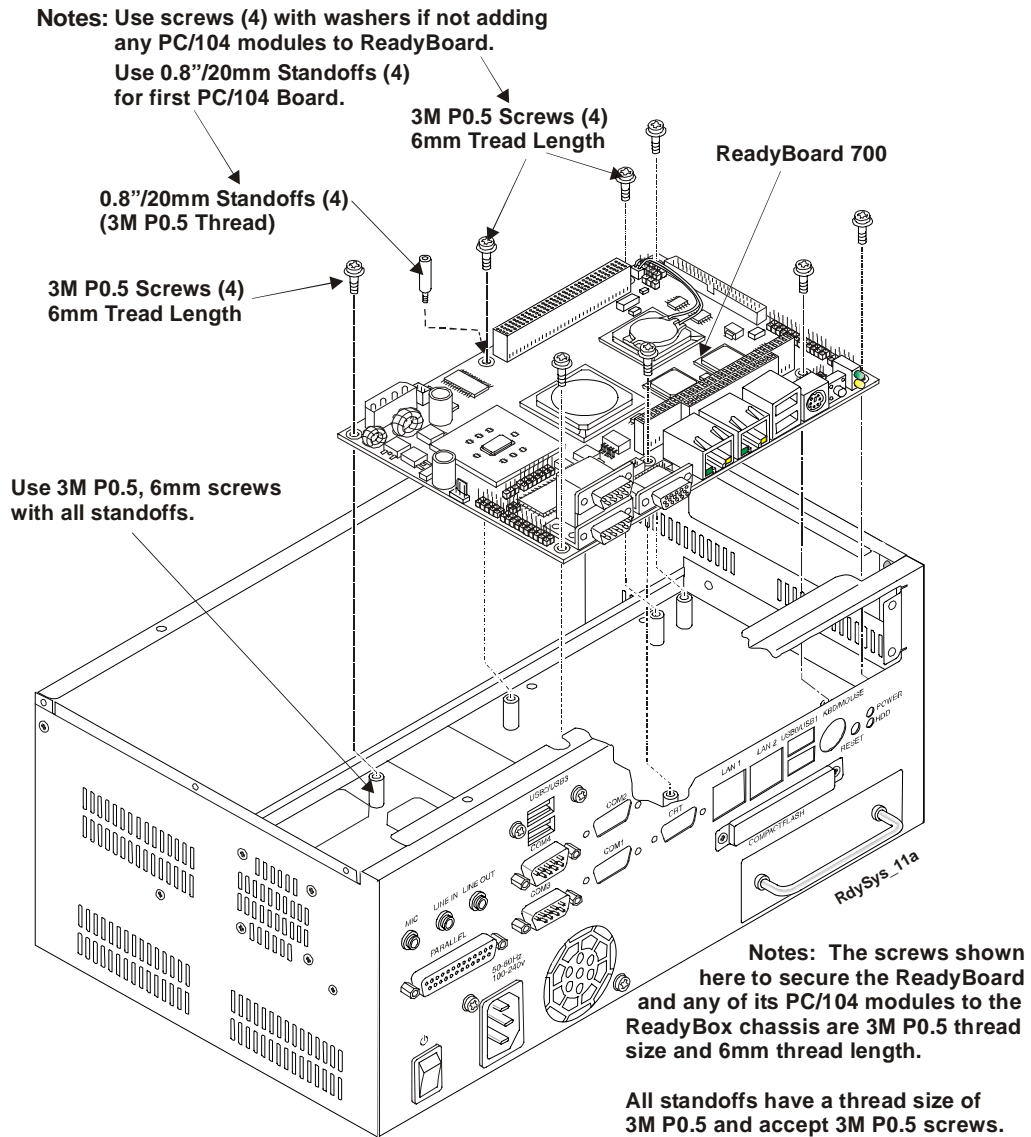

Figure 4-8. ReadyBoard Over Chassis Standoffs

6. Insert the ReadyBoard and its Ethernet connectors just under the lip of the two LAN ports on the enclosure wall, behind the I/O panel. See Figure 4-7.
7. Slowly work the ReadyBoard into place, inserting the I/O connectors and LEDs into the respective openings on the I/O Panel.

When you have the ReadyBoard in position you should clearly see the mounting holes for the eight standoffs under the board mounting holes, and the LEDs should fit into the openings provided on the I/O Panel.

8. Insert four M3 P0.5 6mm screws, with washers, into the standoffs on the enclosure shelf at the four corners of the board. See Figure 4-8.
9. If you are putting a PC/104 board onto the ReadyBoard, insert the four 0.8" (20mm) standoffs provided with the ReadyBoard at the four PC/104 mounting locations. See Figure 4-8.

If you are not installing a PC/104 expansion board, insert four M3 P0.5, 6mm, screws with washers at the four PC/104 mounting locations.

10. Go to the next procedure to connect the cables.

Connecting the Cables

When connecting the cables refer to the pin-1 designations shown in the Figure 4-10. Pin 1 is shown as a black pin (round or square) at the connectors and jumpers, unless otherwise noted. If you desire more installation information than is provided in this guide refer to the ReadyBox Users Guide or the ReadyBoard model QuickStart Guide.

1. Connect the Parallel cable to the Parallel/Floppy connector (J20). See Figures 4-4, 4-9, and 4-10.
2. Connect the IDE cable to the IDE connector (J22). See Figures 4-4, 4-9, and 4-10.
3. Connect the USB 2 & 3 cable to the USB 2 & 3 connector (J21). See Figures 4-4, 4-9, and 4-10.
4. Connect the Power Switch cable (two-wires) to the Utility connector (J18). See Figures 4-4, 4-9, and 4-10.
5. Connect the Audio In/Out cable to the Audio In/Out connector (J19). See Figures 4-4, 4-9, and 4-10.

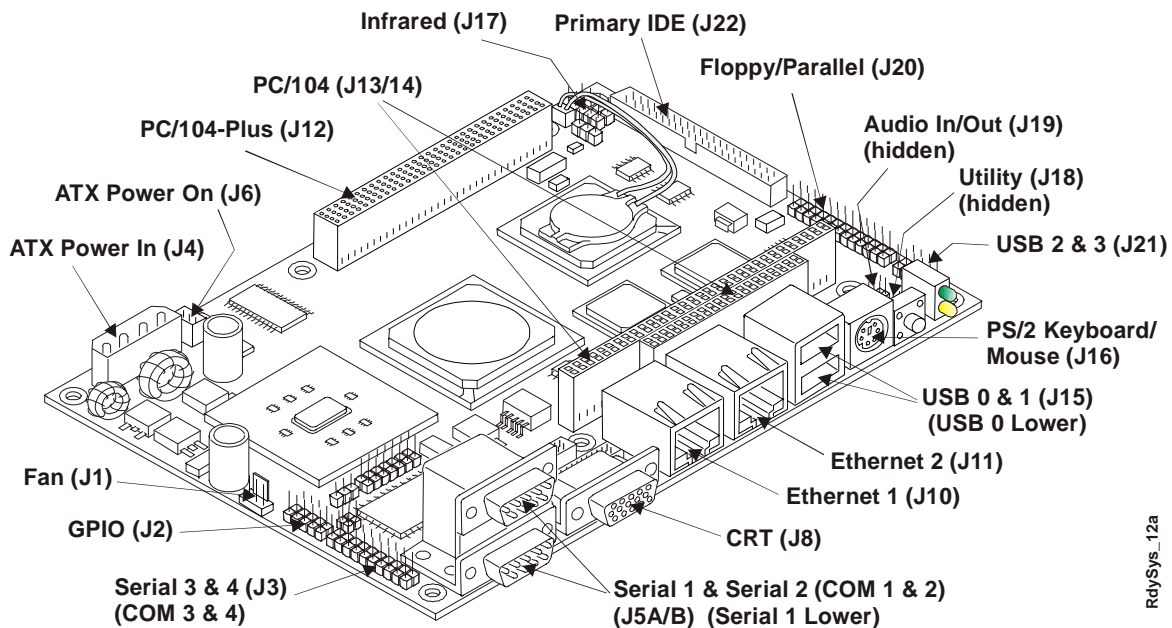

Figure 4-9. Connector and Jumper Locations

6. Connect the Serial 3 & 4 cable to the Serial 3 & 4 connector (J3). See Figures 4-4, 4-9, and 4-10.
7. Connect the ATX Power In cable to the Power In connector (J4). See Figures 4-4, 4-9, and 4-10.

8. Connect the Power on cable to the Power On connector (J6). See Figures 4-4, 4-9, and 4-10.

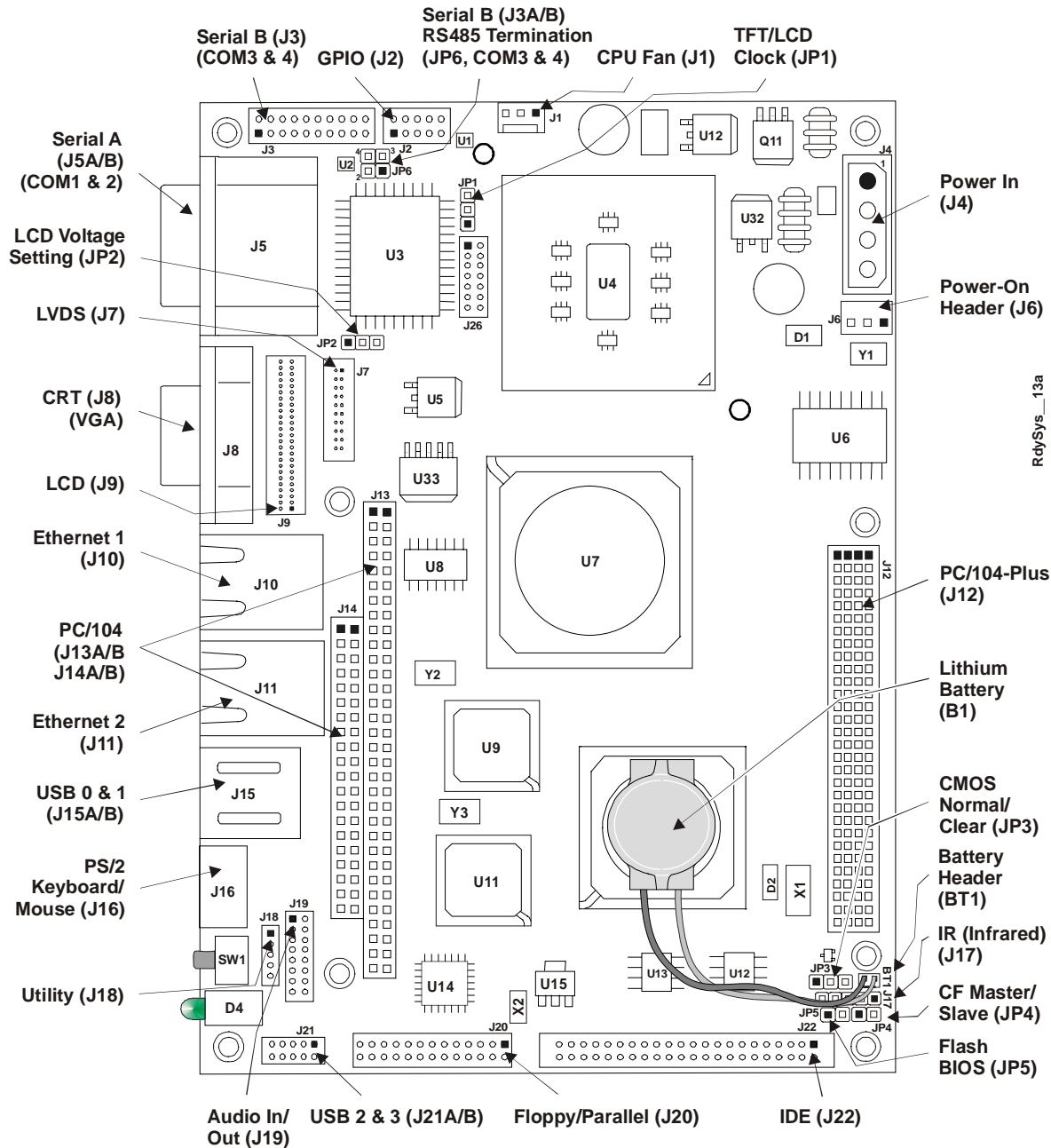

Figure 4-10. Connector Pin-1 Locations

9. You may replace the top cover before restoring power to check ReadySystem operation, or restore power to check system operation before replacing the top cover to the enclosure.

In either case, observe all safety precautions when replacing the top cover or restoring power to the system.

Memory Installation

The ReadyBoard model uses a single SODIMM socket available on the underside of the board. The ReadyBoard SBC must be removed from the ReadySystem enclosure to remove or install the single SODIMM.

NOTE	Refer to the specific ReadyBoard model QuickStart Guide or Reference Manual for SODIMM installation recommendations.
-------------	--

Tools Required

Use an anti-static service kit (or the equivalent) to remove or install the SODIMM. An anti-static service kit should include a static-dissipating work surface, a chassis clip lead, and a wrist or ankle strap.

Installation Guidelines

- When handling a SODIMM, observe anti-static discharge precautions to avoid damage.
- Refer to the specific ReadyBoard model QuickStart Guide or Reference Manual for SODIMM installation recommendations.
- The typical SODIMM sizes are available from Ampro, 64MB, 128MB, 256MB, 512MB, or 1GB, depending on the supported memory size of the ReadyBoard model.
- The supported SODIMM memory size is ReadyBoard model specific.

Removing the SODIMM

Use this procedure to remove the SODIMM from the SODIMM socket on the ReadyBoard.

1. Prepare the ReadyBoard model for SODIMM removal:
 - ◆ If the ReadyBoard model is already prepared for SODIMM removal, with the ReadyBoard removed from the enclosure, then skip to Step 7.
 - ◆ If the ReadyBoard model is installed inside the ReadySystem and operating, continue with next step.

CAUTION	To prevent damage to the ReadyBoard model, ensure the ReadySystem power is turned off and the power cord has been removed from the power source. The internal ATX power supply will continue to provide standby current to the board until the power cord is disconnected.
----------------	--

2. Initiate a shut down sequence through the OS, or hold the power switch in for 4-6 seconds to turn power off.
The Power LED should turn off completely when the power is turned off.
3. Remove the ReadySystem power cord from the AC outlet.
4. Remove the seven screws holding the top cover to the ReadySystem enclosure and then slide the cover to the left as shown in the Figure 4-3.
5. Disconnect the cables to the ReadyBoard model and lay the free ends out of the way.
6. Remove the ReadyBoard model from the ReadySystem enclosure and place on anti-static surface.
Refer to the previous procedures for more information.
7. Turn the ReadyBoard model over to access the bottom of the board while laying on a flat anti-static surface. See Figure 4-11.

CAUTION To prevent damage to the SODIMM, do not touch the SODIMM until you have discharged yourself and followed good Electrostatic Discharge principals. The SODIMMs are sensitive to static electricity and can be easily damaged by improper handling. Do the following when handling a SODIMM:

Leave the SODIMM in the anti-static bag until you are ready to install it.

Always use an anti-static wrist/ankle strap and a grounding mat connected to ground.

Before you remove a SODIMM from the anti-static bag, touch a grounded, unpainted metal surface to discharge any static electricity.

8. Locate the SODIMM socket (DIMM1) on the bottom of the ReadyBoard model. See Figure 4-11.
9. Open both retaining latches to release the SODIMM from the socket. See Figure 4-11.
The SODIMM will spring up to a 45° angle to the board once you open both retaining latches. If the SODIMM does not spring up to a 45° angle, then the retaining latches have not released the SODIMM from the socket.
10. Using the card edges, lift the SODIMM completely away from the socket. See Figure 4-11.
11. Place the SODIMM on an anti-static surface or in an anti-static bag.

NOTE If you remove the SODIMM and restore power without a SODIMM installed, you will not see a display and your system will not work properly.

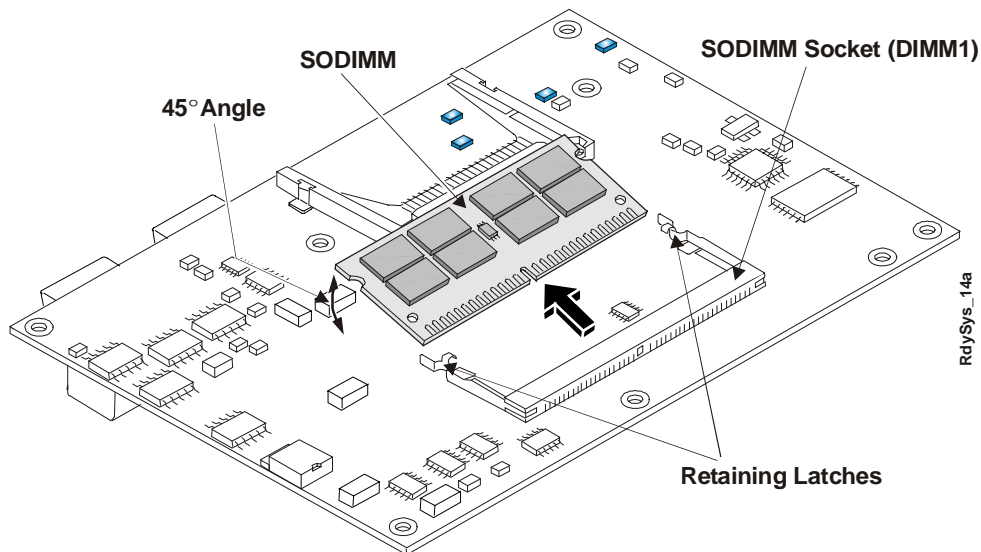

Figure 4-11. Removing SODIMM from Socket

Installing the SODIMM

If you want to install a larger size SODIMM or replace the existing SODIMM, refer to the following procedure.

1. Prepare the ReadyBoard model for SODIMM installation:
 - ◆ If the ReadyBoard model is already prepared for SODIMM installation, with the ReadyBoard removed from the Ready System enclosure and an empty SODIMM socket, skip to Step 4.
 - ◆ If the ReadyBoard model is operating, continue with next step.

CAUTION	To prevent damage to the ReadyBoard model, ensure the ReadySystem power is turned off and the power cord has been removed from the power source. The internal ATX power supply will continue to provide standby current to the board until the power cord is disconnected.
----------------	--

2. Initiate a shut down sequence through the OS, or hold the power switch in for 4-6 seconds to turn power off.

The Power LED should turn off completely when the power is turned off.

CAUTION	To prevent damage to the SODIMM, do not touch the SODIMM until you have discharged yourself and followed good Electrostatic Discharge principals. The SODIMMs are sensitive to static electricity and can be easily damaged by improper handling. Do the following when handling a SODIMM: Leave the SODIMM in the anti-static bag until you are ready to install it. Use an anti-static wrist/ankle strap and a grounding mat connected to ground. Before you remove a SODIMM from the anti-static bag, touch a grounded, unpainted metal surface to discharge any static electricity.
----------------	--

3. Remove the ReadySystem power cord from the AC outlet.
4. Remove the seven screws holding the top cover to the ReadySystem enclosure and then slide the cover to the left as shown in the Figure 4-13.
5. Disconnect the cables to the ReadyBoard model and lay the free ends out of the way.
6. Remove the ReadyBoard model from the ReadySystem enclosure and place on anti-static surface. Refer to the previous procedures for more information.
7. Turn the ReadyBoard model over to access the bottom of the board while laying on a flat anti-static surface. See Figure 4-11.
8. If you need to remove the existing SODIMM from the SODIMM socket before continuing, refer to the previous procedure beginning with Step 9.

Follow Step 9 to 11 in the proceeding procedure, *Removing the SODIMM*, before continuing with the next step in this procedure.
9. Remove the SODIMM from its protective bag, handling the SODIMM by its edges.

NOTE	Refer to the specific ReadyBoard model QuickStart Guide or Reference Manual for SODIMM installation recommendations.
-------------	--

10. Ensure there is nothing in the SODIMM socket that would prevent its installation.

11. Insert the SODIMM into the socket at 45° angle to the bottom of the ReadyBoard model with the components facing up. See Figure 4-12.

The SODIMM card edge and socket are keyed to install into the socket in only one direction.

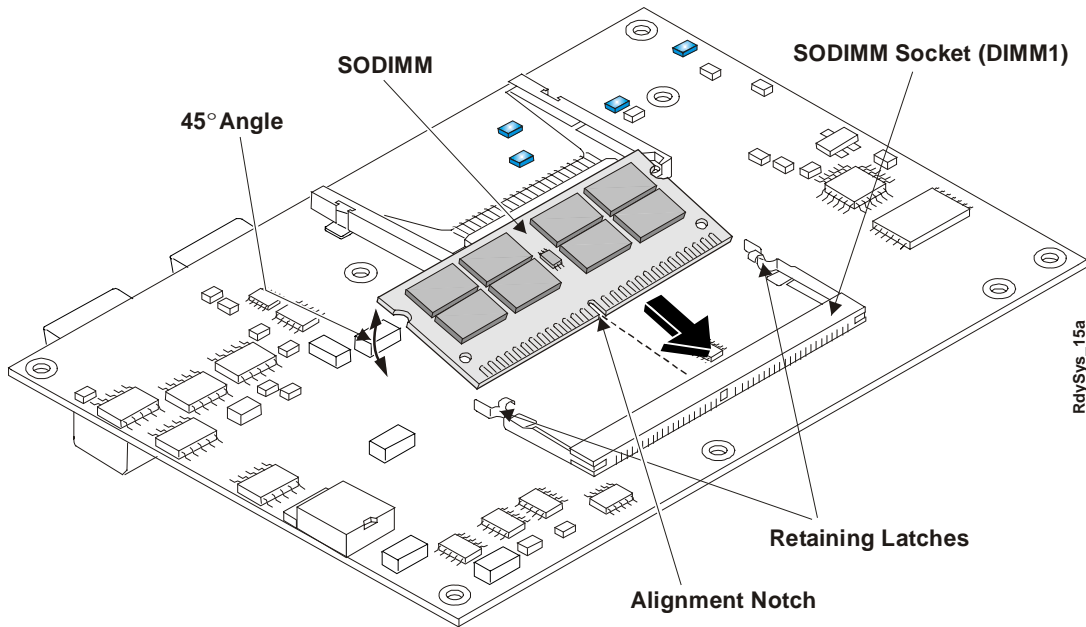

Figure 4-12. Installing SODIMM into Socket

12. Press the edges of the SODIMM down between the latches, until the latches snap into place. See Figure 4-12.
The latches should open to accept the SODIMM without any resistance. If you encounter any resistance, you may not have inserted the SODIMM far enough into the socket.
13. If the retaining latches do not close completely on the SODIMM, remove it and repeat Steps 10 to 12.
14. Reinstall the ReadyBoard model into the ReadySystem enclosure.
Refer to the *Installing the ReadyBoard* procedure for more information.
15. Reconnect the cables to the ReadyBoard model.
Refer to the *Connecting the Cables* procedure for more information.
16. Restore power to the ReadySystem and observe the boot screen for new memory recognition.
If the system does not boot or there is a problem recognizing the new memory, the new SODIMM could be defective or the SODIMM was not properly installed or recognized.

Appendix A Technical Support

Contacting Support

Ampro Computers, Inc. provides a number of methods for contacting Technical Support as listed in Table A-1 below. Requests for support through Ask an Expert are given the highest priority, and usually will be addressed within one working day.

- Ampro Ask an Expert – This is a comprehensive support center designed to meet all your technical needs. This service is free and available 24 hours a day through the Ampro web site at <http://ampro.custhelp.com>. This includes a searchable database of Frequently Asked Questions, which will help you with the common information requested by most customers. This is a good source of information to look at first for your technical solutions. However, you must register online before you can log in to access this service.
- Personal Assistance – You may also request personal assistance by creating an Ask an Expert account and then going to the Ask a Question feature. Requests can be submitted 24 hours a day, 7 days a week. You will receive immediate confirmation that your request has been entered. Once you have submitted your request, you must log in to My Stuff where you can check status, update your request, and access other features.
- InfoCenter – This service is also free and available 24 hours a day at the Ampro web site at <http://www.ampro.com>. However, you must sign up online before you can log in to access this service.

The InfoCenter was created as a resource for embedded system developers to share Ampro's knowledge, insight, and expertise. This page contains links to White Papers, Specifications, and additional technical information.

Table A-1. Technical Support Contact Information

Method	Contact Information
Ask an Expert	http://ampro.custhelp.com
Web Site	http://www.ampro.com
Standard Mail	Ampro Computers, Incorporated 5215 Hellyer Avenue San Jose, CA 95138-1007, USA

